

MICROTM on the Apple

Volume 3

INCLUDES
DISKETTE



MICRO on the Apple 3

Notice

Apple is a registered trademark of Apple Computer, Inc.
MICRO is a trademark of MICRO INK, Inc.

Preliminary article selection, Ford Cavallari; final article selection, program testing, debugging, and modification, Tim Osborn; technical assistance, Darryl Wright; copyediting, Marjorie Morse.

Cover Design and Graphics, Kate Winter

Every effort has been made to supply complete and accurate information. However, MICRO INK, Inc., assumes no responsibility for its use, nor for infringements of patents or other rights of third parties which would result.

Copyright© 1982 by MICRO INK, Inc.
P.O. Box 6502 (34 Chelmsford Street)
Chelmsford, Massachusetts 01824

All rights reserved. With the exception noted below, no part of this book or the accompanying floppy disk may be stored in a retrieval system, transmitted, or reproduced in any way, including but not limited to photocopy, photograph, magnetic or other record, without prior agreement and written permission of the publisher.

To the extent that the contents of this book is replicated on the floppy disk enclosed with the book, it may be stored for retrieval in an Apple Computer. The original retail purchaser is permitted to make one (1) copy of the disk solely for his own back-up purposes.

MICRO on the Apple Series ISSN: 0275-3537
MICRO on the Apple Volume 3 ISBN: 0-938222-08-2
Printed in the United States of America
Printing 10 9 8 7 6 5 4 3 2 1
Floppy disk produced in the United States of America

MICRO on the Apple 3

Edited by the staff of
MICRO, The 6502/6809 Journal

MICRO INK
P.O. Box 6502
Chelmsford, Massachusetts 01824

Contents

	INTRODUCTION	1
1	APPLESOFT AIDS	3
	Applesoft Line Finder Routine	5
	<i>Peter J.G. Meyer</i>	
	Amper-Search	9
	<i>Alan G. Hill</i>	
	Applesoft Variable Lister	24
	<i>Richard Albright</i>	
2	MACHINE-LANGUAGE AIDS	37
	Double Barrelled Disassembler	39
	<i>David L. Rosenberg</i>	
	Cross Referencing 6502 Programs	48
	<i>Cornelis Bongers</i>	
	A Fast Fractional Math Package for 6502 Microcomputers	65
	<i>Wes Huntress</i>	
	Applesoft Error Messages from Machine Language	84
	<i>Steve Cochard</i>	
3	I/O ENHANCEMENTS	87
	Serial Line Editor	89
	<i>Wes Huntress</i>	
	Trick DOS	100
	<i>Sanford M. Mossberg</i>	
	LACRAB	107
	<i>N.R. McBurney</i>	
4	GRAPHICS	125
	Apple Color Filter	127
	<i>Stephen R. Berggren</i>	
	True 3-D Images	131
	<i>Art Radcliffe</i>	
	Apple Bits	136
	<i>Richard C. Vile</i>	

5 TUTORIAL/REFERENCE 155

- Apple Byte Table 157
Kim G. Woodward
- How Microsoft BASIC Works 164
Greg Paris

6 RECREATION/APPLICATIONS 175

- A Simple Securities Manager 177
Ronald A. Guest
- Solar System Simulation 186
Dave Partyka
- Othello 196
Charles F. Taylor, Jr.
- Musical Duets 201
Rick Brown

LANGUAGE INDEX	215
AUTHOR INDEX	216
DISK INFORMATION	218

1

APPLESOFT AIDS

Applesoft Line Finder Routine <i>Peter J.G. Meyer</i>	5
Amper-Search <i>Alan G. Hill</i>	9
Applesoft Variable Lister <i>Richard Albright</i>	24

Applesoft Aids

In this chapter we have included utilities to speed up execution and to help with program development.

“Amper-Search,” by Alan Hill, will help speed up the task of searching a string array for a specified character string. An added bonus is the `&DEALLOC`, which will de-allocate a string or integer array. These two functions together will greatly increase the speed and efficiency of programs that deal with array processing.

“Applesoft Line Finder Routine” by Peter Meyer will give the user a hex dump of any Applesoft program line, allowing him to insert otherwise unavailable characters into the program text. “Variable Lister” could prove invaluable to someone maintaining a complex program; it dumps all variable values at any point requested without disturbing normal program execution. An added bonus is a 6502 assembly version of the famous Shell-Metzner sort.

Applesoft Line Finder Routine

by Peter J.G. Meyer

This 55-byte machine-language program will display the bytes constituting a specified line in an Applesoft program. This program also demonstrates how you can use the subroutines available in Applesoft and the Apple Monitor.

The Applesoft Interpreter (at \$D000-\$F7FF) and the Apple Monitor (\$F800-\$FFFF) contain many useful machine-language subroutines. One such subroutine, FNDLIN (at \$D61A), finds the location in memory of a given line of an Applesoft program.

To see why you might wish to do this, consider the following simple problem: how do you print "APPLE][PLUS" from within a program? This is easily reduced to two simpler problems: how to print "]" and "["? The former is available on the Apple keyboard in the guise of shift-M, but you cannot enter the latter from the keyboard. A solution is to include in your Applesoft program the line PRINT "APPLE]Z PLUS", and then replace the hexadecimal number which represents 'Z' (namely, \$5A) with the number which represents '[' (namely, \$5B). This requires examination of the region of memory containing the tokenized form of the PRINT statement, locating the \$5A, and replacing it with \$5B. In the case of an Applesoft program composed of only a few lines, this can be done by direct inspection of memory using the Monitor. But, if your program has hundreds of lines, then another method is called for.

Listing 1 is a short, machine-language program which is invoked (from BASIC command mode) by a statement of the form

```
CALL LOCATION, LINE
```

where LOCATION is the location (in decimal) of the machine-language routine (it is relocatable), and LINE is the number of the line in the program to be searched for. If the routine finds the line, then it will display the bytes constituting the line and leave you in Monitor mode. (To return to BASIC command mode, enter Control-C.) If there is no line of the specified number in the Applesoft program, then the only result is a beep.

Suppose the routine is loaded or assembled at \$300 (decimal 768), your Applesoft program is in RAM, and you wish to find the location of line 3370, which is, say, PRINT "]X". If you enter CALL 768,3370 then the bytes constituting the line will be displayed as follows:

```
xxxx- yy zz 2A 0D BA 22 5D 5A 22 00
```

where xxxx is the address of the start of the line, yy zz is the pointer to the beginning of the next line (low-byte first), 2A 0D is the line number in hexadecimal (low-byte first), and 00 is the end-of-line token. The remaining five bytes are the tokenized form of the statement PRINT "]Z" (PRINT is represented by one byte: BA). If, for example, the address of the line is \$1A92 then (from Monitor mode) you can enter:

```
1A99: 5B
```

which has the effect of replacing the byte '5A' with the byte '5B'. If (after Control-C-ing back to BASIC) the line is then LISTed, it will appear as PRINT "]]", and will print accordingly.

For those readers without assemblers, the routine may be entered from Monitor mode by typing in 300: 20 BE DE 20 OC (See listing 1 for the remaining bytes.) Once entered, it may be saved to disk by entering BSAVE LINE FINDER, A\$300, L\$37. To use it, BLOAD LINE FINDER and proceed as above.

Apart from the utility, this routine is interesting because it relies almost entirely on subroutines in the Applesoft Interpreter and the Monitor, which is why it is only 55 bytes long. The five Applesoft subroutines and three Monitor subroutines which are used are given in listing 1 along with their addresses.

The routine works as follows: after you enter CALL 768,3370, this statement is placed in the buffer (at \$200) and the zero page pointer TXTPTR is set to the first byte (the token for CALL). Upon invocation of the routine at location 768, TXTPTR is pointing to the comma, and the subroutine CHKCOM checks for this. (If there is no comma, a syntax error message results.) The routine then gets the line number using the subroutine LINGET, and places this (in hexadecimal form, low byte first) at LINNUM. The subroutine FNDLIN picks up this number and searches the Applesoft program for the line so numbered. If it does not find such a line, it returns with the carry flag clear. In this case the routine sounds the bell and returns to BASIC command mode.

If FNDLIN finds the line, then it returns with the carry flag set. It then deposits the address of the line at LOWTR (low byte first, as usual). The routine stores this address at A1, for later use by the subroutine XAM (eXAMine memory), which will display the bytes constituting the line.

Having found the address of the beginning of the line, the subroutines REMN and ADDON are used to find the address of the end. To use the subroutine REMN, which searches from the byte pointed to by TXTPTR until it finds an end-of-line token (00), the routine first sets TXTPTR to four places past the beginning of the line. This action skips the link pointer and the line number, since the line number may contain 00 (as in 0A 00, representing 10), which would mislead REMN. REMN is then invoked, and returns with the offset to the end-of-line in the Y register. ADDON adds this offset to TXTPTR, so that TXTPTR is then pointing to the end of the line. This address is stored at A2, and XAM is invoked to display the bytes from A1 to A2.

8 Applesoft Aids

```

0800      1 ;*****
0800      2 ;*
0800      3 ;*          LINE FINDER          *
0800      4 ;*              BY              *
0800      5 ;*          PETER MEYER          *
0800      6 ;*
0800      7 ;*    COPYRIGHT (C) 1982          *
0800      8 ;*    MICRO INK, INC.            *
0800      9 ;*    CHELMSFORD, MA 01824       *
0800     10 ;*    ALL RIGHTS RESERVED     *
0800     11 ;*
0800     12 ;*****
0800     13 ;
0800     14 ;
0800     15 ;
0300     16          ORG $300          ;RELOCATABLE
0300     17          OBJ $800
0300     18 ;
0300     19 ;
0300     20 ;
0300     21 ;APPLESOFT SUBROUTINES
0300     22 ;
0300     23 ;
D61A     24 FNDLIN    EQU $D61A
D998     25 ADDON    EQU $D998
D9A6     26 REMN     EQU $D9A6
DA0C     27 LINGET   EQU $DA0C
DEBE     28 CHKCOM   EQU $DEBE
0300     29 ;
0300     30 ;
0300     31 ;MONITOR SUBROUTINES
0300     32 ;
0300     33 ;
FDB3     34 XAM      EQU $FDB3
FF3A     35 BELL     EQU $FF3A
FF69     36 MONZ     EQU $FF69
0300     37 ;
0300     38 ;
0300     39 ;ZERO PAGE LOCATIONS
0300     40 ;
0300     41 ;
003C     42 A1      EPZ $3C
003E     43 A2      EPZ $3E
0050     44 LINNUM   EPZ $50
009B     45 LOWTR    EPZ $9B
00B8     46 TXTPTR   EPZ $B8
0300     47 ;
0300     48 ;
0300 20 BE DE     49          JSR CHKCOM          ;CHECK FOR COMMA
0303 20 0C DA     50          JSR LINGET          ;GET LINE NUMBER
0306 20 1A D6     51          JSR FNDLIN          ;SEARCH FOR LINE IN BASIC PROG
RAM
0309 B0 03       52          BCS FOUND
030B 4C 3A FF     53          JMP BELL              ;NOT FOUND
030E A5 9B       54          FOUND    LDA LOWTR          ;STORE STARTING ADDRESS AT A1
0310 A4 9C       55          LDY LOWTR+1
0312 85 3C       56          STA A1
0314 84 3D       57          STY A1+1
0316 A5 9B       58          LDA LOWTR          ;SET TXTPTR TO STARTING
0318 18          59          CLC              ;ADDRESS+4
0319 69 04       60          ADC #$04
031B 85 B8       61          STA TXTPTR
031D A5 9C       62          LDA LOWTR+1
031F 69 00       63          ADC #$00
0321 85 B9       64          STA TXTPTR+1
0323 20 A6 D9     65          JSR REMN              ;FIND END OF LINE
0326 20 98 D9     66          JSR ADDON          ;SET TXTPTR TO END OF LINE
0329 A5 B8       67          LDA TXTPTR
032B A4 B9       68          LDY TXTPTR+1
032D 85 3E       69          STA A2              ;STORE ENDING ADDRESS AT A2
032F 84 3F       70          STY A2+1
0331 20 B3 FD     71          JSR XAM              ;DISPLAY MEMORY FROM A1 TO A2
0334 4C 69 FF     72          JMP MONZ            ;ENTER MONITOR MODE
0337           73          END

```

Amper-Search

by Alan G. Hill

High speed machine language search routine finds character strings in BASIC arrays.

Amper-Search is a high-speed character search routine that will find and return the subscripts of all occurrences of a specified character string in a target string array. A search of a 2000 element array will take less than 1 second compared to about 90 seconds for an equivalent BASIC routine. Parameters are used to name the target string array, define the character string, define the bounds of the search, and name the variables to receive the subscripts and number of matches. An added bonus in the Amper-Search code is another routine called &DEALLOC. This routine gives your BASIC program the ability to de-allocate a string array or integer array when it's no longer needed. &DEALLOC can be used with any Applesoft BASIC program.

Let's look at the parameters and how they are passed between the Applesoft program and Amper-Search. The general form is:

```
&S[EARCH](NA$,L,H,ST$,PL,PH,I%,N%)
```

where:

[] bracket optional characters. The "&S" are required characters.

NA\$ is the variable name of the single-dimensional string array to be searched.

L is a variable, constant, or expression specifying the value of the subscript of NA\$ where the search is to begin; i.e. NA\$(L).

H is a variable, constant, or expression specifying the value of the subscript of NA\$ where the search is to end; i.e. NA\$(H).

ST\$ is the variable name of the simple string containing the "search" characters. A special case exists if the string contains a Control N character. See note 1.

PL is a variable, constant, or expression specifying the character position in the NA\$(I) string where the search is to begin.

PH is a variable, constant, or expression specifying the character position in the NA\$(I) string where the search is to end. PL and PH are equivalent to the MID\$ statement of the form: MID\$(NA\$(I), PL, PH - PL + 1).

I% is the name of the single-dimensional integer array into which the subscripts of NA\$ will be placed when a "match" is found. The first occurrence will be placed in I%(0). A special case exists if I% is a simple variable rather than an array variable. See note 5.

N% is the name of the simple integer variable into which the number of "matches" will be placed by Amper-Search. N% should be set to zero each time before Amper-Search is invoked. Setting N% < 0 is a special case. See note 6.

After Amper-Search is invoked, the elements of NA\$ which match the ST\$ string may be listed with the statement: FOR I=0 TO N% - 1: PRINT NA\$(I%(I)): NEXT I.

Notes

1. A match is defined as the consecutive occurrence of all characters in ST\$ with those in NA\$(L) through NA\$(H) and within the PL and PH character positions of NA\$(I). A Control N character in the ST\$ string is a wild card. It will match any character in its corresponding NA\$(I) position.
2. Any valid variable name may be used as a parameter. An "=" will match anything.
3. $0 \leq L \leq H \leq$ maximum number of elements in NA\$. Elements of NA\$ can be null strings.
4. $1 \leq PL \leq PH \leq 255$. A $PH > LEN(NA$(I))$ is allowed and will ensure that the entire NA\$(I) string is searched.
5. I% must be dimensioned large enough to hold all matches; i.e. DIM I%(N%). Since you don't know the number of matches before Amper-Search is invoked, you have two alternatives. I% can be dimensioned the same size as NA\$, thus assuring enough space to accommodate a complete match. This may waste memory or require more memory than is available. A second alternative is to first define I% as a *simple* variable before invoking Amper-Search. In this special case, Amper-Search will return the number of matches *only*. Your program can then DIM I%(N%), set N%=0, and re-invoke Amper-Search to return the subscripts. Its speed makes this option practical even for large arrays and will conserve memory by not allocating unused I% elements.
6. N% should be ≤ 0 prior to invoking Amper-Search. Set N%=0 if you want all matches. If N%=0 upon return, there were no matches. Set N% = -1 if you only want the *first* occurrence of a match. In this special case, N% will be -1 if there were no matches, or +1 if a match were found. The subscript of the matching NA\$ element will be found in I%(0).

Note 5 described a method for allocating the minimum size for I% that is large enough to hold the maximum number of matches. You could ask, "What if I use &SEARCH iteratively with a different ST\$ string each time that has more matches than I% can hold? Won't that cause a BAD SUBSCRIPT ERROR?" Yes it will. Ideally, you would like to de-allocate I% and re-DIMension it at the new minimum size. The CLEAR command won't do the job because it will clear all variables. Now you should see the utility of yet another Amper-library routine called &DEALLOC which performs the needed function. The general form is:

&D[EALLOC] (A,B,N)

where A,B,N are the named variables of the integer and string arrays to be de-allocated.

[] bracket optional characters. "&D" are required.

For example: &D(I%) will de-allocate the I% integer array, &D(XY\$,K%) will de-allocate the XY\$ string array and the K% integer array.

To complete the de-allocation process, your program must follow the &D(XY\$) statement with an X=FRE(0) housekeeping statement to regain the memory from character strings referred to only by the de-allocated string array. &DEALLOC cannot be used to increase the size of an array while preserving the current contents of the array.

Now let's look at some simple examples created by running the program in listing 1.

Listing 2 is a general BASIC demo you can experiment with to learn how Amper-Search can be used.

Some of the routines in Amper-Search can be adapted for use in other Amper-library machine language routines. The following routines may be useful:

GNAME retrieves the string or integer variable name from the "&" parameter list and places it in the NAME buffer in your machine language program. The A register is returned with a "\$" or "%" character.

INTE converts the positive ASCII variable name in NAME to Applesoft's 2-character negative ASCII naming convention for integer variable names. If the A register does not contain a "%" upon entry, the carry flag will be set upon return.

STRING performs the same function for string variable names as INTE does for integer variables. The A register must contain a "\$" upon entry.

12 *Applesoft Aids*

FARRAY will search variable space for the array variable name contained in the **NAME** buffer. If found, its address will be returned in the **X** and **Y** registers. If not found, the carry flag will be set.

FSIMPL performs the same function for simple variables as **FARRAY** does for array variables.

&DEALLOC also uses several of the above routines. Similar routines which can be adapted reside somewhere in the Applesoft interpreter.

```

1 REM *****
2 REM *
3 REM *   AMPER-SEARCH1   *
4 REM *   ALAN G. HILL   *
5 REM *
6 REM *   COPYRIGHT (C) 1982 *
7 REM *   MICRO INK, INC.  *
8 REM *   CHELMSFORD, MA 01824 *
9 REM *   ALL RIGHTS RESERVED *
10 REM *
11 REM *****
12 REM
13 REM
14 HIMEM: 9 * 4096 + 2 * 256
15 D$ = CHR$(4): PRINT D$"NOMONIC,I,O"
16 PRINT D$"BLOAD B.AMPER-SEARCH(48K)"
17 POKE 1013,76: POKE 1014,0: POKE 1015,146: REM 3F5:JMP $9200
18 DIM NA$(10),I%(10)
20 NA$(0) = "APPLE CORE"
21 NA$(1) = "CRAB APPLE"
22 NA$(2) = "APPLE&ORANGE"
23 NA$(3) = "APPLE/ORANGE"
24 LIST 18,23
100 REM FIND ALL OCCURRENCES OF 'APPLE'
101 N% = 0:ST$ = "APPLE"
102 & SEARCH(NA$,0,10,ST$,1,255,I%,N%)
103 LIST 100,102: GOSUB 2000: GOSUB 3000
200 REM FIND 'APPLE' IN NA$(0)->NA$(1) COLUMNS 1->5
201 N% = 0:ST$ = "APPLE"
202 & SEARCH(NA$,0,1,ST$,1,5,I%,N%)
203 LIST 200,202: GOSUB 2000: GOSUB 3000
300 REM FIND 'APPLE ORANGE'
301 N% = 0:ST$ = "APPLE" + CHR$(14) + "ORANGE"
302 & SEARCH(NA$,0,3,ST$,1,255,I%,N%)
303 LIST 300,302: GOSUB 2000: GOSUB 3000
400 REM FIND 1ST 'ORANGE'
401 N% = -1:ST$ = "ORANGE"
402 & SEARCH(NA$,0,3,ST$,1,255,I%,N%)
403 LIST 400,402: GOSUB 2000: GOSUB 3000
490 ST$ = "CRAB"
492 REM DYNAMICALLY ALLOCATE/DEALLOCATE M%
495 FOR J = 1 TO 2
500 N% = 0:K% = 0
501 & SEARCH(NA$,0,3,ST$,1,255,K%,N%)
502 DIM M%(N%):N% = 0
503 & SEARCH(NA$,0,3,ST$,1,255,M%,N%)
504 LIST 490,530: GOSUB 2100: GOSUB 3000
510 & DEALLOC(M%)
520 ST$ = "APPLE"
530 NEXT J
600 REM FIND 'E' IN COLUMN 10
601 N% = 0:ST$ = "E"
602 & SEARCH(NA$,0,3,ST$,10,10,I%,N%)
603 LIST 600,602: GOSUB 2000
700 END
2000 IF N% = 0 THEN PRINT "NONE FOUND": RETURN
2005 FOR I = 0 TO N% - 1
2010 HTAB 4: PRINT NA$(I%(I))
2020 NEXT I
2030 PRINT : RETURN
2100 IF N% = 0 THEN PRINT "NONE FOUND": RETURN
2105 PRINT
2110 FOR I = 0 TO N% - 1
2120 HTAB 4: PRINT NA$(M%(I))
2130 NEXT I
2140 PRINT : RETURN
3000 FOR I = 1 TO 5000: NEXT I: RETURN

```

J

```

1  REM *****
2  REM *
3  REM *      AMPER-SEARCH2      *
4  REM *      ALAN G. HILL      *
5  REM *
6  REM *      COPYRIGHT (C) 1982 *
7  REM *      MICRO INK, INC.    *
8  REM *      CHELMSFORD, MA 01824 *
9  REM *      ALL RIGHTS RESERVED *
10 REM *
11 REM *****
12 REM
13 REM
1000 GOSUB 10000
1010 POKE 32,20: POKE 33,19: HOME : VTAB 5: PRINT "DO YOU WANT TO": PRINT
"SPECIFY SEARCH": PRINT "LIMITS(Y/N)?"; GET A$: PRINT
1020 IF A$ < > "Y" THEN 1080
1030 VTAB 10: CALL - 868: INPUT "LOWER SUBSCRIPT: "; L: IF L < 0 OR L > 2
1 THEN PRINT B$: GOTO 1030
1040 VTAB 12: CALL - 868: INPUT "UPPER SUBSCRIPT: "; U: IF H < 0 OR H > 2
1 OR H < L THEN PRINT B$: GOTO 1040
1050 VTAB 14: CALL - 868: INPUT "LOWER COLUMN: "; PL: IF PL < 1 OR PL > 2
55 THEN PRINT B$: GOTO 1050
1060 VTAB 16: CALL - 868: INPUT "UPPER COLUMN: "; PH: IF PH < 1 OR PH > 2
55 OR PH < PL THEN PRINT B$: GOTO 1060
1065 VTAB 18: CALL - 868: PRINT "FIRST/ALL?"; GET A$: PRINT : IF A$ =
"F" THEN F% = - 1
1070 GOTO 1120
1080 L = 0: REM START AT NA$(0)
1090 H = I: REM SEARCH ALL
1100 PL = 1: REM START WITH 1ST COLUMN
1110 PH = 255: REM MAXIMUM COLUMNS
1115 F% = 0: REM FIND ALL
1120 POKE 32,0: POKE 33,39: VTAB 23: CALL - 868
1130 INVERSE : PRINT "STRING: "; NORMAL : INPUT " "; ST$
1140 IF LEN (ST$) = 0 THEN END
1150 N% = F%: REM INIT COUNTER
1160 REM INVOKE 'AMPER-SEARCH'
1170 & SEARCH(NA$,L,H,ST$,PL,PH,I%,N%)
1180 REM LIST FOUND STRINGS
1190 POKE 32,20: POKE 33,19: HOME
1200 IF N% < = 0 THEN PRINT "NONE FOUND": GOTO 1120
1210 FOR I = 0 TO N% - 1
1220 VTAB I%(I) + 1: PRINT NA$(I%(I))
1230 NEXT I
1240 GOTO 1120
10000 REM HOUSEKEEPING
10010 HIMEM: 9 * 4096 + 2 * 256
10015 POKE 235,0
10020 D$ = CHR$(4)
10030 B$ = CHR$(7)
10040 PRINT D$"NOMONIC,I,0"
10050 POKE 1013,76: POKE 1014,0: POKE 1015,146: REM SETUP '&' VECTOR AT
$3F5 TO JMP $9200
10060 TEXT : HOME : VTAB 10: HTAB 12: PRINT "AMPER-SEARCH DEMO"
10070 HTAB 19: PRINT "BY": HTAB 14: PRINT "ALAN G. HILL"
10080 PRINT D$"BLOAD B.AMPER-SEARCH(48K)"
10090 FOR I = 1 TO 1000: NEXT I
10100 DIM NA$(22),I$(22)
10110 I = 0
10120 REM INITIALIZE STRING ARRAY
10130 READ NA$(I)
10140 IF NA$(I) = "END" THEN 10160
10150 I = I + 1: GOTO 10130
10160 I = I - 1
10170 HOME
10180 FOR K = 0 TO I
10190 PRINT K; TAB(4);NA$(K)
10200 NEXT K

```

```

10210 RETURN
11000 REM SAMPLE STRINGS
11010 REM NOTE: THIS DEMO IS SCREEN ORIENTED. DON'T PUT MORE THAN 22 IT
      EMS IN THE DATA STATEMENT LIST.
11020 DATA APPLE II,APPLE SIDER,APPLE CIDER,APPLEVENTION,APPLE PI,APPLE
      SAUCE,APPLE TREE,APPLE ORCHARD
11030 DATA APPLE II PLUS, APPLES & ORANGES ,APPLE BLOSSOM,CANDIED APPL
      ES,APPLE/ORANGE,APPLESOFT,APPLEODIAN,APPLEVISION
11040 DATA APPLE STEM,APPLE CORE,APPLE-A-DAY,APPLE PIE,APPLE PEEL,APPLE
      -OF-MY-EYE
11050 DATA END
  
```

```

0800      1 ;*****
0800      2 ;*
0800      3 ;*      AMPER-SEARCH      *
0800      4 ;*          BY      *
0800      5 ;*      ALAN G. HILL      *
0800      6 ;*
0800      7 ;*      COPYRIGHT (C) 1982      *
0800      8 ;*      MICRO INK, INC.      *
0800      9 ;*      CHELMSFORD, MA 01824      *
0800     10 ;*      ALL RIGHTS RESERVED      *
0800     11 ;*
0800     12 ;*****
0800     13 ;
0800     14 ;
00D0     15 NAPTR      EPZ $D0
00D2     16 SAPTR      EPZ $D2
00D4     17 JAPTR      EPZ $D4
00D6     18 NPT      EPZ $D6
00D8     19 L      EPZ $D8
00DA     20 H      EPZ $DA
00DC     21 PL      EPZ $DC
00DD     22 PH      EPZ $DD
00DE     23 TEM6X      EPZ $DE
00E0     24 NAPTH      EPZ $E0
00E2     25 CNAPTR      EPZ $E2
00E4     26 CSAPTR      EPZ $E4
00E6     27 SAVEY      EPZ $E6
00E7     28 PS      EPZ $E7
00E8     29 LENNA      EPZ $E8
00E9     30 LENSEA      EPZ $E9
00EA     31 SWITCH      EPZ $EA
00EB     32 SIZE      EPZ $EB
00D2     33 OFFSET      EPZ $D2
00D4     34 A1      EPZ $D4
0050     35 Z50      EPZ $50
00B7     36 CHRGET      EPZ $B7
00B1     37 CHRGET      EPZ $B1
FDDED     38 COUT      EQU $FDED
0800     39 ;          ROM          RAM
E6F8     40 GETBYT      EQU $E6F8      ;LEEF
DEC9     41 SYNERR      EQU $DEC9      ;16CC
DD67     42 FRMNUM      EQU $DD67      ;156A
E752     43 GETADR      EQU $E752      ;1F49
0800     44 ;
9200     45 ;          ORG $9200
9200     46 ;          OBJ $800
9200     47 ;
9200     48 ;PROCESS &
9200 48     49 BEGIN      PHA
9201 20 35 95     50 JSR SAVEZP      ;SAVE ZERO PG
9204 68     51 PLA
9205 A2 02     52 LDX #$02
9207 CA     53 CHRSPN      DEX
9208 30 53     54 BMI ERRX
920A DD A9 95     55 CMP CHRTBL,X      ;'S' OR 'D'
920D D0 F8     56 BNE CHRSPN      ;TRY AGAIN
920F 8A     57 TXA
9210 0A     58 ASL          ;TIMES 2
9211 AA     59 TAX
9212 20 B1 00     60 SR02      JSR CHRGET      ;NEXT CHAR
9215 F0 46     61 BEQ ERRX
9217 C9 28     62 CMP #$28      ; (
9219 D0 F7     63 BNE SR02
  
```

16 *Applesoft Aids*

```

921B BD A6 95    64      LDA LOC+01,X          ;JMP TO
921E 48          65      PHA                  ;ROUTINE
921F BD A5 95    66      LDA LOC,X            ;VIA
9222 48          67      PHA                  ;RTS
9223 60          68      RTS
9224            69      ;
9224            70      ; ** AMPER-SEARCH **
9224            71      ;
9224 20 22 94    72      SEARCH JSR GNAME          ;GET NAME
9227 20 61 94    73      JSR STRING        ;CONVERT
922A 20 78 94    74      JSR FARRAY          ;FIND NAME
922D B0 34       75      BCS ERRV
922F 86 D0       76      STX NAPTR
9231 84 D1       77      STY NAPTR+01
9233 20 B1 00    78      JSR CHRGET
9236 20 67 DD    79      JSR FRMNUM
9239 20 52 E7    80      JSR GETADR
923C A5 50       81      LDA Z50
923E 85 D8       82      STA L                ;LOWER SUBSC
9240 A5 51       83      LDA Z50+01
9242 85 D9       84      STA L+01
9244 20 B1 00    85      JSR CHRGET
9247 20 67 DD    86      JSR FRMNUM
924A 20 52 E7    87      JSR GETADR
924D A5 50       88      LDA Z50
924F 85 DA       89      STA H                ;UPPER SUBSC
9251 A5 51       90      LDA Z50+01
9253 85 DB       91      STA H+01
9255 20 22 94    92      JSR GNAME
9258 20 61 94    93      JSR STRING
925B 90 1D       94      BCC SR20
925D            95      ;
925D            96      ; ** ERROR **
925D            97      ;
925D 20 5A 95    98      ERRX JSR RSZP
9260 4C C9 DE    99      JMP SYNERR
9263            100     ;
9263            101     ; ** VARIABLE NOT FOUND MSG. **
9263            102     ;
9263 A2 00       103     ERRV LDX #S00
9265 BD AB 95    104     SR18 LDA MSG1,X          ;ERROR MSG
9268 C9 C0       105     CMP #S00        ;@ DELIMITER
926A FD F1       106     BEQ ERRX
926C 09 30       107     ORA #S80
926E 20 ED FD    108     JSR COUT
9271 E0 0C       109     CPX #S0C
9273 D0 02       110     BNE SR19
9275 A2 19       111     LDX #S19
9277 E8         112     SR19 INX
9278 D0 EB       113     BNE SR18
927A 20 B2 94    114     SR20 JSR FSIMPL
927D B0 E4       115     BCS ERRV
927F 86 D2       116     STX SAPTR
9281 84 D3       117     STY SAPTR+01
9283 20 B1 00    118     JSR CHRGET
9286 20 F8 E6    119     JSR GETBYT
9289 86 DC       120     STX PL                ;FIRST POSITION
928B 20 B1 00    121     JSR CHRGET
928E 20 F8 E6    122     JSR GETBYT
9291 86 DD       123     STX P1                ;LAST POSITION
9293 20 22 94    124     JSR GNAME
9296 20 41 94    125     JSR INTE
9299 B0 C2       126     BCS ERRX
929B 20 78 94    127     JSR FARRAY
929E 90 09       128     BCC SR21
92A0 20 B2 94    129     JSR FSIMPL
92A3 B0 BE       130     BCS ERRV
92A5 A9 FF       131     LDA #SFF
92A7 85 EB       132     STA SIZE          ;# OF HITS ONLY
92A9 86 D4       133     SR21 STX JAPTR
92AB 84 D5       134     STY JAPTR+01
92AD 20 22 94    135     JSR GNAME
92B0 20 41 94    136     JSR INTE
92B3 B0 AB       137     BCS ERRX

```

```

92B5 20 B2 94 138 JSR FSIMPL
92B8 B0 A9 139 BCS ERRV
92BA B5 D5 140 STX NPT ;N$
92BC B4 D7 141 STY NPT+01
92BE 20 B1 00 142 JSR CHRGET
92C1 D0 9A 143 BNE ERRX
92C3 144 ;
92C3 145 ; ** FINISHED PARAMETERS **
92C3 146 ;
92C3 147 ; ** SET UP POINTERS **
92C3 148 ;
92C3 18 149 CLC
92C4 A5 D4 150 LDA JAPTR
92C6 69 07 151 ADC #$07
92C8 B5 D4 152 STA JAPTR ;I$
92CA A5 D5 153 LDA JAPTR+01
92CC 69 00 154 ADC #$00
92CE B5 D5 155 STA JAPTR+01
92D0 A5 DA 156 LDA H
92D2 B5 50 157 STA Z50
92D4 A5 DB 158 LDA H+01
92D6 B5 51 159 STA Z50+01
92D8 A9 03 160 LDA #$03
92DA B5 54 161 STA $54
92DC A9 00 162 LDA #$00
92DE B5 55 163 STA $55
92E0 20 E9 94 164 JSR MPLY
92E3 B6 E0 165 STX NAPTR+1 ;NA$(H)
92E5 B4 E1 166 STY NAPTR+01
92E7 A5 D8 167 LDA L
92E9 B5 50 168 STA Z50
92EB A5 D9 169 LDA L+01
92ED B5 51 170 STA Z50+01
92EF 20 E9 94 171 JSR MPLY
92F2 B6 D0 172 STX NAPTR ;NA$(L)
92F4 B4 D1 173 STY NAPTR+01
92F6 174 ;
92F6 18 175 CLC
92F7 A5 D2 176 LDA SAPTR
92F9 69 02 177 ADC #$02
92FB B5 D2 178 STA SAPTR ;ST$
92FD A5 D3 179 LDA SAPTR+01
92FF 69 00 180 ADC #$00
9301 B5 D3 181 STA SAPTR+01
9303 A0 00 182 LDY #$00
9305 B1 D2 183 LDA (SAPTR),Y
9307 D0 03 184 BNE SR22
9309 4C 1E 94 185 JMP RETURN ;NULL
930C B5 E9 186 SR22 STA LENA
930E C3 187 INY
930F B1 D2 188 LDA (SAPTR),Y ;SAVE
9311 B5 E4 189 STA CSAPTR ;ADDRESS
9313 C8 190 INY
9314 B1 D2 191 LDA (SAPTR),Y
9316 B5 E5 192 STA CSAPTR+01
9318 193 ;
9318 194 ; ** START SEARCH **
9318 195 ;
9318 A0 00 196 NEXT LDY #$00
931A B1 D0 197 LDA (NAPTR),Y
931C F0 4E 198 BEQ NEXTNA ;NULL
931E B5 E8 199 STA LENA ;LEN(NA$( ))
9320 C8 200 INY
9321 B1 D0 201 LDA (NAPTR),Y
9323 B5 E2 202 STA CNAPTR
9325 C8 203 INY
9326 B1 D0 204 LDA (NAPTR),Y
9328 B5 E3 205 STA CNAPTR+01
932A A4 DC 206 LDY PL
932C B8 207 DEY
932D C4 E8 208 CPY LENA
932F B0 3B 209 BCS NEXTNA
9331 A9 00 210 NXTNAC LDA #$00
9333 B5 E7 211 STA PS ;CURRENT POSITION

```

18 *Applesoft Aids*

```

9335 85 EA      212          STA SWITCH
9337 B1 E2      213  CONT   LDA (CNAPTR),Y
9339 C8         214          INY
933A 84 E6      215          STY SAVEY
933C A4 E7      216          LDY PS
933E D1 E4      217          CMP (CSAPTR),Y
9340 F0 0A      218          BEQ SR25          ;POSSIBLE MATCH
9342 B1 E4      219          LDA (CSAPTR),Y
9344 C9 3D      220          CMP #3D          ;MATCH ANYTHING
9346 F0 45      221          BEQ MATCH
9348 C9 0E      222          CMP #0E          ;CNTL N
934A D0 11      223          BNE SR26          ;NOT WILD CARD
934C           224          ;
934C           225          ; ** POSSIBLE MATCH **
934C           226          ;
934C A9 FF      227  SR25   LDA #$FF
934E 85 EA      228          STA SWITCH
9350 C8         229          INY
9351 C4 E9      230          CPY LENA
9353 F0 38      231          BEQ MATCH          ;AT END?
9355 E6 E7      232          INC PS          ;IT'S A MATCH!
9357 F0 13      233          BEQ NEXTNA
9359 A4 E6      234          LDY SAVEY
935B D0 DA      235          BNE CONT          ;ALWAYS
935D A4 E6      236  SR26   LDY SAVEY
935F 24 EA      237          BIT SWITCH
9361 10 01      238          BPL SR28
9363 88         239          DEY
9364 C4 E8      240  SR28   CPY LENNA          ;AT END?
9366 B0 04      241          BCS NEXTNA          ;BR YES
9368 C4 DD      242          CPY PH          ;LAST POSITION
936A 90 C5      243          BCC NXTNAC          ;NEXT CHARACTER
936C 18         244  NEXTNA  CLC          ;NEXT NA$(I)
936D A5 D0      245          LDA NAPTR
936F 69 03      246          ADC #03
9371 85 D0      247          STA NAPTR
9373 A5 D1      248          LDA NAPTR+01
9375 69 00      249          ADC #00
9377 85 D1      250          STA NAPTR+01
9379 E6 D8      251          INC L
937B D0 02      252          BNE SR33
937D E6 D9      253          INC L+01
937F 38         256  SR33   SEC
9380 A5 E0      257          LDA NAPTR
9382 E5 D0      258          SBC NAPTR
9384 A5 E1      259          LDA NAPTR+01
9386 E5 D1      260          SBC NAPTR+01
9388 B0 8E      261          BCS NEXT
938A 4C 1E 94   262          JMP RETURN          ;AT NA$(H)
938D           263          ;
938D           264          ; ** FOUND A MATCH **
938D           265          ;
938D 24 EB      266  MATCH   BIT SIZE
938F 30 18      267          BMI SZONLY          ; # MATCHES ONLY
9391 A0 00      268          LDY #00
9393 A5 D9      269          LDA L+01          ;SUBSCRIPT
9395 91 D4      270          STA (JAPTR),Y
9397 C8         271          INY
9398 A5 D8      272          LDA L
939A 91 D4      273          STA (JAPTR),Y
939C 18         274          CLC
939D A5 D4      275          LDA JAPTR
939F 69 02      276          ADC #02
93A1 85 D4      277          STA JAPTR
93A3 A5 D5      278          LDA JAPTR+01
93A5 69 00      279          ADC #00
93A7 85 D5      280          STA JAPTR+01
93A9 A0 03      281  SZONLY  LDY #03
93AB 18         282          CLC
93AC B1 D6      283          LDA (NPT),Y
93AE 69 01      284          ADC #01          ;N%=N%+1
93B0 91 D6      285          STA (NPT),Y
93B2 88         286          DEY

```

```

93B3 B1 D6      287      LDA (NPT),Y
93B5 30 07      288      BMI ONLY1          ; 1ST OCCURRENCE
93B7 69 00      289      ADC #00
93B9 91 D6      290      STA (NPT),Y
93BB 4C 6C 93   291      JMP NEXTNA
93BE A9 00      292      ONLY1 LDA #00
93C0 91 D6      293      STA (NPT),Y
93C2 C8         294      INY
93C3 A9 01      295      LDA #01          ; N% = 1
93C5 91 D6      296      STA (NPT),Y
93C7            297      ;
93C7            298      ; ** FINISHED AMPER-SEARCH **
93C7            299      ;
93C7 4C 1E 94   300      JMP RETURN
93CA 4C 5D 92   301      ERRXX JMP ERRX
93CD 4C 63 92   302      ERRVX JMP ERRV
93D0            303      ;
93D0            304      ; ** DEALLOCATE **
93D0            305      ;
93D0 20 22 94   306      DEALLO JSR GNAME      ; GET NAME
93D3 C9 24      307      CMP #024          ; $
93D5 F0 05      308      BEQ RE50
93D7 20 41 94   309      JSR INTE        ; %
93DA D0 03      310      BNE RE55        ; ALWAYS
93DC 20 61 94   311      RE50 JSR STRING
93DF B0 E9      312      RE55 BCS ERRXX
93E1 20 78 94   313      JSR FARRAY
93E4 B0 E7      314      BCS ERRVX
93E6 86 D0      315      STX NAPTR      ; NA$
93E8 84 D1      316      STY NAPTR+01
93EA A0 02      317      LDY #02
93EC B1 D0      318      LDA (NAPTR),Y
93EE 85 D2      319      STA OFFSET
93F0 C8         320      INY
93F1 B1 D0      321      LDA (NAPTR),Y
93F3 85 D3      322      STA OFFSET+01
93F5 18         323      CLC
93F6 A5 D2      324      LDA OFFSET
93F8 65 D0      325      ADC NAPTR
93FA 85 D4      326      STA A1
93FC A5 D3      327      LDA OFFSET+01
93FE 65 D1      328      ADC NAPTR+01
9400 85 D5      329      STA A1+01
9402 20 18 95   330      JSR MOVE        ; MOVE VARIABLES
9405 38         331      SEC
9406 A5 6D      332      LDA $6D
9408 E5 D2      333      SBC OFFSET
940A 85 6D      334      STA $6D
940C A5 6E      335      LDA $6E
940E E5 D3      336      SBC OFFSET+01
9410 85 6E      337      STA $6E
9412 20 B7 00   338      JSR CHRGOT
9415 C9 29      339      CMP #029        ; )
9417 D0 B7      340      BNE DEALLO    ; NEXT VAR
9419 20 B1 00   341      JSR CHRGET
941C D0 AC      342      BNE ERRXX
941E            343      ;
941E            344      ; ** FINISHED **
941E            345      ;
941E 20 5A 95   346      RETURN JSR RSZP      ; RESTORE PAGE0
9421 60         347      RTS
9422            348      ;
9422            349      ; *****
9422            350      ; SUBROUTINES
9422            351      ; *****
9422            352      ;
9422            353      ; ** GET VARIABLE NAME **
9422            354      ;
9422 A2 00      355      GNAME LDX #00
9424 20 B1 00   356      GRO1 JSR CHRGET
9427 C9 2C      357      CMP #02C        ; ,
9429 F0 11      358      BEQ GRO3
942B C9 29      359      CMP #029        ; )
942D F0 0D      360      BEQ GRO3

```

20 *Applesoft Aids*

```

942F 9D B5 95 361          STA NAME,X          ;SAVE NAME
9432 E8          362          INX
9433 E0 10      363          CPX #$10          ;16 IS ENOUGH
9435 D0 ED      364          BNE GR01
9437 68          365          PLA
9438 68          366          PLA          ;POP STACK
9439 4C 5D 92   367          JMP ERRX
943C CA          368          DEX
943D BD B5 95   369          LDA NAME,X          ; $ OR %
9440 60          370          RTS
9441          371          ;
9441          372          ; ** INTEGER NAME **
9441          373          ;
9441 C9 25      374          INTE    CMP #$25          ;%
9443 D0 1A      375          BNE ERRI          ;NOT %
9445 8D B7 95   376          STA NAME+02        ;SAVE
9448 E0 01      377          CPX #$01          ;NAME
944A D0 04      378          BNE GR10          ;IN
944C A9 80      379          LDA #$80          ;APPLESOFT
944E D0 07      380          BNE GR14          ;FORMAT
9450 A2 01      381          GR10   LDX #$01
9452 A9 80      382          GR12   LDA #$80
9454 1D B5 95   383          ORA NAME,X
9457 9D B5 95   384          GR14   STA NAME,X
945A CA          385          DEX
945B 10 F5      386          BPL GR12
945D 18          387          CLC          ;CLEAR ERR
945E 60          388          RTS
945F 38          389          ERRI    SEC          ;SET ERR
9460 60          390          RTS
9461          391          ;
9461          392          ; ** STRING NAME **
9461          393          ;
9461 C9 24      394          STRING  CMP #$24          ;$
9463 D0 11      395          BNE ERRS
9465 8D B7 95   396          STA NAME+02
9468 A9 80      397          LDA #$80
946A E0 01      398          CPX #$01          ;SAVE
946C F0 03      399          BEQ GR18          ;NAME
946E OD B6 95   400          ORA NAME+01
9471 8D B6 95   401          GR18   STA NAME+01
9474 18          402          CLC
9475 60          403          RTS
9476 38          404          ERRS   SEC          ;SET ERR
9477 60          405          RTS
9478          406          ;
9478          407          ; ** FIND ARRAY NAME **
9478          408          ; ** IN VARIABLE SPACE **
9478          409          ;
9478 A5 6B      410          FARRAY  LDA $6B
947A 85 DE      411          STA TEM6X
947C A5 6C      412          LDA $6C
947E 85 DF      413          STA TEM6X+01
9480 A0 00      414          F02    LDY #$00
9482 B1 DE      415          LDA (TEM6X),Y
9484 CD B5 95   416          CMP NAME          ;1ST CHARACTER
9487 D0 08      417          BNE F04
9489 C8          418          INY
948A B1 DE      419          LDA (TEM6X),Y
948C CD B6 95   420          CMP NAME+01        ;2ND CHARACTER
948F F0 1B      421          BEQ FOUND
9491 18          422          F04    CLC
9492 A0 02      423          LDY #$02          ;LOOK AT
9494 B1 DE      424          LDA (TEM6X),Y        ;NEXT NAME
9496 65 DE      425          ADC TEM6X
9498 48          426          PHA
9499 C8          427          INY
949A B1 DE      428          LDA (TEM6X),Y
949C 65 DF      429          ADC TEM6X+01
949E 85 DF      430          STA TEM6X+01
94A0 68          431          PLA
94A1 85 DE      432          STA TEM6X
94A3 C5 6D      433          CMP $6D
94A5 A5 DF      434          LDA TEM6X+01
94A7 E5 6E      435          SBC $6E

```

```

94A9 90 D5      436          BCC F02          ;TRY NEXT ONE
94AB 60         437          RTS            ;NOT FOUND
94AC           438
94AC A6 DE     439 FOUND    LDX TEM6X          ;RTN WITH
94AE A4 DF     440          LDY TEM6X+01       ;ADDRESS
94B0 18        441          CLC
94B1 60        442          RTS
94B2           443
94B2           444          ; ** FIND SIMPLE NAME **
94B2           445          ; ** IN VARIABLE SPACE **
94B2           446
94B2 A5 69     447 FSIMPL   LDA $69
94B4 85 DE     448          STA TEM6X
94B6 A5 6A     449          LDA $6A
94B8 85 DF     450          STA TEM6X+01
94BA A0 00     451 FS2      LDY #$00
94BC B1 DE     452          LDA (TEM6X),Y
94BE CD B5 95  453          CMP NAME          ;1ST CHARACTER
94C1 D0 08     454          BNE FS4
94C3 C8        455          INY
94C4 B1 DE     456          LDA (TEM6X),Y
94C6 CD B6 95  457          CMP NAME+01      ;2ND CHARACTER
94C9 F0 18     458          BEQ FOUNDS
94CB 18        459 FS4      CLC            ;TRY NEXT ONE
94CC A5 DE     460          LDA TEM6X
94CE 69 07     461          ADC #$07        ;DISPLACEMENT
94D0 85 DE     462          STA TEM6X
94D2 A5 DF     463          LDA TEM6X+01
94D4 69 00     464          ADC #$00
94D6 85 DF     465          STA TEM6X+01
94D8 A5 DE     466          LDA TEM6X
94DA C5 6D     467          CMP $6D         ;AT END?
94DC A5 DF     468          LDA TEM6X+01
94DE E5 6E     469          SBC $6E
94E0 90 D8     470          BCC FS2
94E2 60        471          RTS            ;NEXT ONE
94E3           472          ;NOT FOUND
94E3 A6 DE     473 FOUNDS   LDX TEM6X          ;RTN WITH
94E5 A4 DF     474          LDY TEM6X+01     ;ADDRESS
94E7 18        475          CLC
94E8 60        476          RTS
94E9           477
94E9           478          ; ** MULTIPLY ROUTINE **
94E9           479
94E9 18        480 MPLY     CLC
94EA A5 D0     481          LDA NAPTR
94EC 69 07     482          ADC #$07
94EE 85 52     483          STA $52
94F0 A5 D1     484          LDA NAPTR+01
94F2 69 00     485          ADC #$00
94F4 85 53     486          STA $53
94F6           487
94F6           488          ; ** FROM 'RED' MANUAL **
94F6           489
94F6 A0 10     490          LDY #$10
94F8 A5 50     491 MUL2    LDA $50
94FA 4A        492          LSR
94FB 90 0C     493          BCC MUL4
94FD 18        494          CLC
94FE A2 FE     495          LDX #$FE
9500 B5 54     496 MUL3    LDA $54,X
9502 75 56     497          ADC $56,X
9504 95 54     498          STA $54,X
9506 E8        499          INX
9507 D0 F7     500          BNE MUL3
9509 A2 03     501 MUL4    LDX #$03
950B 76 50     502 MUL5    ROR $50,X
950D CA        503          DEX
950E 10 FB     504          BPL MUL5
9510 88        505          DEY
9511 D0 E5     506          BNE MUL2
9513 A6 50     507          LDX Z50
9515 A4 51     508          LDY Z50+01
9517 60        509          RTS

```

22 Applesoft Aids

```

9518          510 ;
9518          511 ; ** MOVE VARIABLES **
9518          512 ;
9518 A0 00     513 MOVE      LDY #$00
951A B1 D4     514 MV01     LDA (A1),Y
951C 91 D0     515          STA (NAPTR),Y
951E E6 D0     516          INC NAPTR
9520 D0 02     517          BNE NXTA1
9522 E6 D1     518          INC NAPTR+01
9524 A5 D4     519 NXTA1    LDA A1
9526 C5 6D     520          CMP $6D
9528 A5 D5     521          LDA A1+01
952A E5 6E     522          SBC $6E
952C E6 D4     523          INC A1
952E D0 02     524          BNE MV02
9530 E6 D5     525          INC A1+01
9532 90 E6     526 MV02     BCC MV01          ;NEXT ONE
9534 60        527          RTS
9535          528 ;
9535          529 ; ** SAVE ZERO **
9535          530 ; ** PAGE SPACE **
9535          531 ;
9535 A2 00     532 SAVEZP   LDX #$00
9537 B5 D0     533 SV02     LDA NAPTR,X
9539 9D D6 95  534          STA ZPSV,X
953C E8        535          INX
953D E0 20     536          CPX #$20          ;SAVE
953F D0 F6     537          BNE SV02          ;32 SPOTS
9541 A2 00     538          LDX #$00
9543 86 EB     539          STX SIZE          ;INIT
9545 B5 50     540 SV04     LDA $50,X          ;ALSO $50, $55
9547 9D D0 95  541          STA SV50,X
954A E8        542          INX
954B E0 06     543          CPX #$06
954D D0 F6     544          BNE SV04
954F A2 0F     545          LDX #$0F
9551 A9 20     546          LDA #$20          ;CLEAR
9553 9D B5 95  547 CLEAR    STA NAME,X          ;NAME AREA
9556 CA        548          DEX
9557 10 FA     549          BPL CLEAR
9559 60        550          RTS
955A          551 ;
955A          552 ; ** RESTORE ZERO **
955A          553 ; ** PAGE SPACE **
955A          554 ;
955A A2 00     555 RSZP     LDX #$00
955C BD D6 95  556 RS02    LDA ZPSV,X
955F 95 D0     557          STA NAPTR,X
9561 E8        558          INX
9562 E0 20     559          CPX #$20
9564 D0 F6     560          BNE RS02
9566 A2 00     561          LDX #$00
9568 BD D0 95  562 RS04    LDA SV50,X
956B 95 50     563          STA $50,X
956D E8        564          INX
956E E0 06     565          CPX #$06
9570 D0 F6     566          BNE RS04
9572 60        567          RTS
9573          568 ;
9573          569 ; ** DATA STORAGE **
9573          570 ;
9573 C1 CD D0   571          HEX C1CDD0C5D2ADD3C5C1D2C3C8
9576 C5 D2 AD
9579 D3 C5 C1
957C D2 C3 C8
957F C1 CC C1   572          HEX C1CCC1CEA0C7AEA0C8C9CCCC
9582 CE A0 C7
9585 AE A0 C8
9588 C9 CC CC
958B C3 CF CD   573          HEX C3CFCD CDC5D2C3C9C1CCA0D2C9C7C8D4D3A0
958E CD C5 D2
9591 C3 C9 C1
9594 CC A0 D2
9597 C9 C7 C8
959A D4 D3 A0

```

```

959D D2 C5 D3 574 HEX D2C5D3C5D2D6C5C4
95A0 C5 D2 D6
95A3 C5 C4
95A5 CF 93 575 LOC HEX CF93 ;DEALLOC-1
95A7 23 92 576 HEX 2392 ;SEARCH-1
95A9 44 577 CHRTBL HEX 44 ;D
95AA 53 578 HEX 53 ;S
95AB 8D 579 MSG1 HEX 8D
95AC D6 C1 D2 580 HEX D6C1D2C9C1C2CCC5A0
95AF C9 C1 C2
95B2 CC C5 A0
95B5 A0 A0 A0 581 NAME HEX A0A0A0A0A0A0A0A0A0A0A0A0A0A0A0A0
95B8 A0 A0 A0
95BB A0 A0 A0
95BE A0 A0 A0
95C1 A0 A0 A0
95C4 A0
95C5 8D 582 HEX 8D
95C6 CE CF D4 583 HEX CECFD4A0C6CFD5CCE4
95C9 A0 C6 CF
95CC D5 CE C4
95CF C0 584 HEX C0
95D0 A0 A0 A0 585 SV50 HEX A0A0A0A0A0A0
95D3 A0 A0 A0
95D6 A0 586 ZPSV HEX A0 ; $20 SPACES
95D7 587 END

```

***** END OF ASSEMBLY

SYMBOL TABLE SORTED ALPHABETICALLY

A1	00D4	BEGIN	9200	CHRGET	00B1	CHRGOT	00B7	CHRSFN	9207
CHRTBL	95A9	CLEAR	9553	CNAPTR	00E2	CONT	9337	COUT	FDED
CSAPTR	00E4	DEALLO	93D0	ERRI	945F	ERRS	9476	ERRV	9263
ERRVX	93CD	ERRX	925D	ERRXX	93CA	F02	9480	F04	9491
FARRAY	9478	FOUND	94AC	FOUND5	94E3	FRMNUM	DD67	FS2	94BA
FS4	94CB	FSIMPL	94B2	GETADR	E752	GETBYT	E6F8	GNAME	9422
GR01	9424	GR03	943C	GR10	9450	GR12	9452	GR14	9457
GR18	9471	H	00DA	INTE	9441	JAPTR	00D4	L	00D8
LENNA	00E8	LENSA	00E9	LOC	95A5	MATCH	938D	MOVE	9518
MPLY	94E9	MSG1	95AB	MUL2	94F8	MUL3	9500	MUL4	9509
MUL5	950B	MV01	951A	MV02	9532	NAME	95B5	NAPTH	00E0
NAPTR	00D0	NEXT	9318	NEXTNA	936C	NPT	00D6	NXTA1	9524
NXTNAC	9331	OFFSET	00D2	ONLY1	93BE	PH	00DD	PL	00DC
PS	00E7	RE50	93DC	RE55	93DF	RETURN	941E	RS02	955C
RS04	9568	RSZP	955A	SAPTR	00D2	SAVEY	00E6	SAVEZP	9535
SEARCH	9224	SIZE	00EB	SRO2	9212	SR18	9265	SR19	9277
SR20	927A	SR21	92A9	SR22	930C	SR25	934C	SR26	935D
SR28	9364	SR33	937F	STRING	9461	SV02	9537	SV04	9545
SV50	95D0	SWITCH	00EA	SYNERR	DEC9	SZONLY	93A9	TEM6X	00DE
Z50	0050	ZPSV	95D6						

SYMBOL TABLE SORTED BY ADDRESS

Z50	0050	CHRGET	00B1	CHRGOT	00B7	NAPTR	00D0	SAPTR	00D2
OFFSET	00D2	JAPTR	00D4	A1	00D4	NPT	00D6	L	00D8
H	00DA	PL	00DC	PH	00DD	TEM6X	00DE	NAPTH	00E0
CNAPTR	00E2	CSAPTR	00E4	SAVEY	00E6	PS	00E7	LENNA	00E8
LENSA	00E9	SWITCH	00EA	SIZE	00EB	BEGIN	9200	CHRSFN	9207
SRO2	9212	SEARCH	9224	ERRX	925D	ERRV	9263	SR18	9265
SR19	9277	SR20	927A	SR21	92A9	SR22	930C	NEXT	9318
NXTNAC	9331	CONT	9337	SR25	934C	SR26	935D	SR28	9364
NEXTNA	936C	SR33	937F	MATCH	938D	SZONLY	93A9	ONLY1	93BE
ERRXX	93CA	ERRVX	93CD	DEALLO	93D0	RE50	93DC	RE55	93DF
RETURN	941E	GNAME	9422	GR01	9424	GR03	943C	INTE	9441
GR10	9450	GR12	9452	GR14	9457	ERRI	945F	STRING	9461
GR18	9471	ERRS	9476	FARRAY	9478	F02	9480	F04	9491
FOUND	94AC	FSIMPL	94B2	FS2	94BA	FS4	94CB	FOUND5	94E3
MPLY	94E9	MUL2	94F8	MUL3	9500	MUL4	9509	MUL5	950B
MOVE	9518	MV01	951A	NXTA1	9524	MV02	9532	SAVEZP	9535
SV02	9537	SV04	9545	CLEAR	9553	RSZP	955A	RS02	955C
RS04	9568	LOC	95A5	CHRTBL	95A9	MSG1	95AB	NAME	95B5
SV50	95D0	ZPSV	95D6	FRMNUM	DD67	SYNERR	DEC9	GETBYT	E6F8
GETADR	E752	COUT	FDED						

Applesoft Variable Lister

by Richard Albright

The ability to dump the values of all variables can be immensely helpful in Applesoft program development. The Applesoft Variable Lister provides this ability and can be used with any program, located anywhere in memory.

This Lister may be attached to any Applesoft program by simply merging its Applesoft subroutine with the main program. This can be accomplished using the standard Apple RENUMBER program. Any unused space in which the 71 lines will fit without affecting the normal operation of the program will do, but the end of the program is the recommended location.

Once installed within the program, the Lister can be invoked like any Applesoft subroutine; that is, by means of a GOSUB n statement where n is the number of the first line of the subroutine within the program. This GOSUB can be issued by the main program or from the keyboard.

The Lister will operate under both ROM and RAM Applesoft, but requires the use of a disk drive. The disk drive last accessed before the Lister was invoked must contain a diskette on which the Lister's two machine language routines are stored under the names SHELL-METZNER SORT and APPLESOFT VARIABLE LISTER OBJ. In addition, one file buffer must be available.

Using the Lister

The output from the Lister will appear on both a printer and the screen if the printer is open at the time the Lister is invoked. Otherwise, the output goes to the screen only. The output format for the printer is slightly different from the screen format.

Figure 1 is an example of the printed output format. User responses to prompts have been underlined. When the Lister is invoked, it first queries you for

ALPHA SORT, MEMORY SORT OR QUIT?

with the double-underlined letters appearing in inverse on the screen. A 'Q' response at this point simply terminates the Lister with no further ado. An 'A' response results in an alphabetical listing of variables while an 'M' response will cause variables to be listed in the order stored. After either an 'A' or an 'M' response, the disk drive will activate briefly while a temporary file is created. (More on this later.)

Next, the Lister asks if you would like to display

VALUES OR LOCATIONS?

A 'V' response will give you the current value for each simple variable (as shown in figure 1); an 'L' response produces a display of locations at which the values are stored in memory.

At this point the disk drive will again activate while the APPLESOFT VARIABLE LISTER OBJ and (if ALPHA SORT has been selected) the SHELL-METZNER SORT files are read and another temporary file is created. If sorting is performed, a

SORTING VARIABLE NAMES . . .

message is displayed while the names are being sorted. Usually the sorting process takes only a few seconds.

After a slight pause, the first page of variables will be displayed (and printed if the printer is on). A two-column format is used for all combinations of display options. Numeric values are displayed to full precision, but strings longer than 14 characters are truncated. Forty variables appear on a full page. The message

HIT SPACE BAR TO CONTINUE; 'ESC' TO QUIT

appears on the screen (*not* on the printer) after each page. Pressing the ESC key results in the termination of the Lister (after some more disk activity). Pressing the space bar, on the other hand, causes the next page of simple variables to be displayed. If all simple variables have been displayed, the first page of array variables is produced. Notice that array variable values *cannot* be displayed; only the location of the start of each array is provided — even if VALUES is the selected display mode.

Following the last array page, the Lister is terminated by pressing either the space bar or the ESC key. At this point the disk drive will again briefly activate. If the Lister was invoked from the keyboard, an error message will be encountered and can be ignored. If invoked from the main program, execution continues normally with the statement following the GOSUB.

Figure 1: Example of Printed Output

APPLESOFT VARIABLE LISTER
ALPHA SORT, MEMORY SORT OR QUIT? A
VALUES OR LOCATIONS? V
SORTING VARIABLE NAMES...

Simple Variables, Alpha Order			
Var	Value	Var	Value
A	0	LB\$	[
A \$		ML%	3
B1\$	3 LETTERS	MQ	99
B2\$	0	MR	99
BS\$		NL%	12
CA\$		NQ%	9
CL\$	CLOSE	NR	12
CR\$			
D	0	NR%	0
D \$		NS%	10
EQ	1	O0\$	OPEN SURVEY C
ER%	1	O1\$	OPEN SURVEY T
F1\$	TEST1	O2\$	OPEN INTERVIE
FQ%	9	OP\$	OPEN SURVEY T
I	96	PP	0
J	0	Q	1
K	0	QQ	1
L	0	R	0
L1	9	R0\$	READ SURVEY C
L2	1	R1\$	READ SURVEY T
RR	1	RE\$	READ SURVEY C
RT%	4		
SS	0		
T \$			
UN	2048		
V	5		
W2\$	WRITE INTERVI		
XR%	1		
ZZ	1		

Array Variables, Alpha Order					
Var	Hex	Dec	Var	Hex	Dec
CT	\$2DB2	11698			
DT\$	\$33F5	13301			
QC	\$2F99	12185			
R \$	\$3194	12692			

The Source Code

The Applesoft Variable Lister consists of an Applesoft subroutine (listing 1), a machine language setup routine (listing 2), and a machine language sort routine (listing 3). The Applesoft subroutine can be entered and SAVED under an arbitrary name. The machine language routines may be entered into memory either directly using the monitor or indirectly using an assembler, then BSAVED under the names APPLESOFT VARIABLE LISTER OBJ (for the setup routine) and SHELL-METZNER SORT (for the sort routine).

Technical Notes

The Lister's Applesoft subroutine occupies about 3500 bytes of memory. In addition, execution of the Lister requires a certain amount of free space: five bytes per variable if the ALPHA SORT option is chosen and ten bytes per variable if the MEMORY SORT option is selected. The Lister does *not* verify that this space is available. If insufficient space exists, the result is unpredictable.

If the addition of the Lister to a program using Hi-Res graphics causes the program to overflow into the Hi-Res memory area, then the merged program should be saved and reloaded above the Hi-Res memory. If only Hi-Res page one is used, this move is accomplished by executing the following POKES between the SAVE and the LOAD:

```
POKE 103,1:POKE 104,64:POKE 16384,0
```

To move the program above Hi-Res page two, use the following POKES:

```
POKE 103,1:POKE 104,96:POKE 24576,0
```

The Lister's Applesoft subroutine itself uses three simple variables (ZZ, ZZ% and ZZ\$) and one array variable (ZZ). These variable names should be avoided in the main program: if they appear in the main program, execution of the Lister subroutine will reset their values. ZZ will always appear in the simple variable listing, but ZZ%, ZZ\$, and the ZZ array variable will appear only if the Lister is executed more than once between CLEARs or RUNs.

Both the SHELL-METZNER SORT and APPLESOFT VARIABLE LISTER OBJ routines use page three of memory. However, the contents of page three at the time the Lister is invoked are saved on diskette in a temporary file named PAGE 3 SAVE. The original page three is restored as part of the Lister termination processing.

Both machine language routines make extensive use of page zero, but again, a temporary file (PAGE 0 SAVE) is used to save the initial values and they are restored when the Lister finishes. However, only part of page zero is restored, leaving some page zero values altered after running the Lister. Specifically, locations 24 to 31 (\$18 to \$1F) are altered. These locations are not normally used by an Applesoft program.

A third temporary file (PAGE 0 SAVE2) is used if ALPHA SORT is selected. It is used to restore page zero values after the sorting has been completed. All temporary files are deleted by the Lister if it terminates normally. Both the SHELL-METZNER SORT and the APPLESOFT VARIABLE LISTER OBJ routines are fully relocatable.

The sorting routine uses the Shell-Metzner algorithm and is designed to sort fixed-length records so that the one with the lowest key value appears highest in the memory. Up to 32,767 records occupying contiguous locations may be sorted with this routine, space permitting. Each record may be up to 255 bytes in length and must have a sort key field that may be as short as one byte or as long as the entire record. The key is evaluated as an unsigned binary integer field and the sorting is performed on that basis.

The sort routine uses memory locations 25 to 31 (\$19 to \$1F) as an input argument list, interpreted as follows:

25	(\$19):	record length
26	(\$1A):	key offset (i.e., record characters preceding the key)
27	(\$1B):	key length
28-29	(\$1C-\$1D):	number of records
30-31	(\$1E-\$1F):	pointer to 1st byte of 1st record

The last two items are two-byte binary integers, presented in the usual low byte/high byte format. The sorting routine does not alter the values placed in any of these locations, nor does it verify their consistency.

Although the sort routine can handle thousands of records, the setup routine can handle a maximum of 255 variables of any type (simple or array). If more than 255 simple or array variables exist, the operation of the Lister is unpredictable.

Strings containing one or more carriage return characters (ASCII 13) cause formatting problems on both the screen and the printer. If the value appears in the left column on the screen, then one variable may be omitted from the right column. On the printer, one or more blank lines may be introduced. This problem is exemplified in figure 1: the CR\$ string consists of a single carriage return character, resulting in the unexpected gap between the CR\$ and D variables in the left column and the NR and NR% variables in the right column.

```

10 REM *****
20 REM *
30 REM * VARIABLE LISTER *
40 REM * RICHARD ALBRIGIT *
50 REM *
60 REM * COPYRIGHT (C) 1982 *
70 REM * MICRO INK, INC. *
80 REM * CHELMSFORD, MA 01824 *
90 REM * ALL RIGHTS RESERVED *
100 REM *
110 REM *****
120 REM
130 REM
140 FOR ZZ = 32 TO 35: POKE 715 + ZZ, PEEK (ZZ): NEXT ZZ
150 POKE 32,0: POKE 33,40: POKE 34,0: POKE 35,24: TEXT: NORMAL
160 PRINT: INVERSE: PRINT SPC( 7);"APPLESOFT VARIABLE LISTER"; SPC( 8
); NORMAL
170 FOR ZZ = 0 TO 9: POKE 752 + ZZ,48 + ZZ: NEXT ZZ: FOR ZZ = 10 TO 15: POKE
752 + ZZ,55 + ZZ: NEXT ZZ
180 PRINT: INVERSE: PRINT "A";: NORMAL: PRINT "LPIA SORT, ";: INVERSE
: PRINT "M";: NORMAL: PRINT "EMORY SORT OR ";: INVERSE: PRINT "Q";
: NORMAL: PRINT "UIT? ";
190 ZZ = PEEK ( - 16384): IF ZZ < 128 THEN 190
200 POKE - 16368,0: PRINT CHR$( ZZ): IF ZZ < > 193 AND ZZ < > 205 AND
ZZ < > 209 THEN PRINT CHR$( 7): GOTO 180
210 IF ZZ = 209 THEN 830
220 ZZ = ZZ - 192: IF ZZ > 1 THEN ZZ = 2
230 POKE 250,ZZ: INVERSE: PRINT "V";: NORMAL: PRINT "ALUES OR ";: INVERSE
: PRINT "L";: NORMAL: PRINT "OCATIONS?";
240 ZZ = PEEK ( - 16384): IF ZZ < 128 THEN 240
250 POKE - 16368,0: PRINT CHR$( ZZ): IF ZZ < > 204 AND ZZ < > 214 THEN
PRINT CHR$( 7): GOTO 250
260 ZZ = ZZ - 204: IF ZZ > 0 THEN ZZ = 2
270 ZZ = ZZ + PEEK (250)
280 PRINT CHR$( 4);"BSAVE PAGE 3 SAVE,A$300,L$100": PRINT CHR$( 4);"BS
AVE PAGE 0 SAVE,A$CO,L$40"
290 PRINT CHR$( 4);"BLOAD APPLESOFT VARIABLE LISTER OBJ": PRINT CHR$( 4
)
300 POKE 250,ZZ:ZZ = FRE (0): CALL 768
310 POKE 251, PEEK (111): POKE 252, PEEK (112): IF PEEK (250) = 2 OR PEEK
(250) = 4 THEN 390
320 PRINT CHR$( 4);"BSAVE PAGE 0 SAVE2,A$CO,L$40": PRINT CHR$( 4)
330 PRINT CHR$( 4);"BLOAD SHELL-METZNER SORT": PRINT CHR$( 4)
340 PRINT: PRINT "SORTING VARIABLE NAMES . . .": PRINT
350 POKE 25,5: POKE 26,0: POKE 27,3
360 ZZ = PEEK (251) + 256 * PEEK (252) + 5 * PEEK (254): POKE 28, PEEK
(253): POKE 29,0: POKE 31, INT (ZZ / 256): POKE 30,ZZ - 256 * PEEK
(31):ZZ = PEEK (254): CALL 768
370 POKE 28,ZZ: POKE 29,0:ZZ = PEEK (30) + 256 * PEEK (31) - 5 * ZZ: POKE
31, INT (ZZ / 256): POKE 30,ZZ - 256 * PEEK (31): CALL 768
380 PRINT CHR$( 4);"BLOAD PAGE 0 SAVE2": PRINT CHR$( 4);"DELETE PAGE 0
SAVE2": PRINT CHR$( 4)
390 HOME: INVERSE: PRINT SPC( 5);"SIMPLE VARIABLES, ";: IF PEEK (250
) = 1 OR PEEK (250) = 3 THEN PRINT "ALPHA ORDER"; SPC( 6);
400 IF PEEK (250) = 2 OR PEEK (250) = 4 THEN PRINT "MEMORY ORDER"; SPC(
5);
410 PRINT: NORMAL: IF PEEK (253) = 0 THEN PRINT: PRINT "NO SIMPLE V
ARIABLES": GOSUB 530: GOTO 450
420 ZZ(0) = PEEK (253):ZZ(1) = PEEK (251) + 256 * PEEK (252) + 5 * ( PEEK
(253) + PEEK (254))
430 IF PEEK (250) > 2 THEN ZZ = ZZ: POKE 25, PEEK (131): POKE 26, PEEK
(132):ZZ$ = ZZ$: POKE 27, PEEK (131): POKE 28, PEEK (132):ZZ% = ZZ%:
POKE 29, PEEK (131): POKE 30, PEEK (132)
440 GOSUB 580
450 IF PEEK (250) > 2 THEN POKE 250, PEEK (250) - 2
460 HOME: INVERSE: PRINT SPC( 6);"ARRAY VARIABLES, ";: IF PEEK (250)
= 1 THEN PRINT "ALPHA ORDER"; SPC( 6);
470 IF PEEK (250) = 2 THEN PRINT "MEMORY ORDER"; SPC( 5);
480 PRINT: NORMAL: IF PEEK (254) = 0 THEN PRINT: PRINT "NO ARRAY VA
RIABLES": GOSUB 530: GOTO 500
490 ZZ(0) = PEEK (254):ZZ(1) = PEEK (251) + 256 * PEEK (252) + 5 * PEEK
(254): GOSUB 580
500 GOTO 790
510 VTAB 2: PRINT "VAR HEX DEC * VAR HEX DEC": PRINT "---- ----
----- * --- ---- ----": RETURN

```

```

520 VTAB 2: PRINT "VAR VALUE" * VAR VALUE": PRINT "---- -----
----- * -----": RETURN
530 ZZ$ = "HIT" + CHR$(96) + "SPACE" + CHR$(96) + "BAR" + CHR$(96) +
"TO" + CHR$(96) + "CONTINUE" + CHR$(123) + CHR$(96) + CHR$(1
03) + "ESC" + CHR$(103) + CHR$(96) + "TO" + CHR$(96) + "QUIT"
540 FOR ZZ = 1 TO LEN (ZZ$): POKE ZZ + 1999, ASC ( MID$( ZZ$,ZZ,1) ) - 6
4: NEXT ZZ
550 ZZ = PEEK ( - 16384): IF ZZ < 128 THEN 550
560 POKE - 16368,0: IF ZZ < > 155 THEN PRINT : PRINT : RETURN
570 POP : POP : GOTO 790
580 REM PRINT VARIABLE NAMES & LOCATIONS
590 ZZ(10) = INT (( PEEK (250) + 1) / 2): ON ZZ(10) GOSUB 510,520: POKE
34,3
600 ZZ(3) = 0:ZZ(1) = ZZ(1) - 5
610 ZZ(2) = ZZ(3) + 1: IF ZZ(2) > ZZ(0) THEN POKE 34,0: RETURN
620 ZZ(3) = ZZ(2) + 19: IF ZZ(3) > ZZ(0) THEN ZZ(3) = ZZ(0)
630 ZZ(6) = ZZ(2) - 1
640 ZZ(6) = ZZ(6) + 1: IF ZZ(6) > ZZ(3) THEN ZZ(1) = ZZ(1) - 100:ZZ(3) =
ZZ(3) + 20: GOSUB 530: HOME : GOTO 610
650 VTAB ZZ(6) - ZZ(2) + 4:ZZ(8) = ZZ(1): GOSUB 670: PRINT SPC( 19 - POS
(0));"* "": IF ZZ(6) + 20 < = ZZ(0) THEN ZZ(8) = ZZ(1) - 100: GOSUB
670
660 PRINT :ZZ(1) = ZZ(1) - 5: GOTO 640
670 PRINT CHR$( PEEK (ZZ(8))) ; CHR$( PEEK (ZZ(8) + 1)) ; CHR$( PEEK (
ZZ(8) + 2)) ; " " : IF ZZ(10) = 2 THEN 730
680 PRINT "$";ZZ(5) = PEEK (ZZ(8) + 4):ZZ(4) = PEEK (ZZ(8) + 3):ZZ(7)
= INT (ZZ(5) / 16): PRINT CHR$( PEEK (752 + ZZ(7))) ; CHR$( PEEK
(752 + ZZ(5) - 16 * ZZ(7)));
690 ZZ(7) = INT (ZZ(4) / 16): PRINT CHR$( PEEK (752 + ZZ(7))) ; CHR$( PEEK
(752 + ZZ(4) - 16 * ZZ(7)));
700 ZZ$ = STR$( 256 * ZZ(5) + ZZ(4))
710 PRINT SPC( 6 - LEN (ZZ$));ZZ$:
720 RETURN
730 ZZ(9) = PEEK (ZZ(8) + 3) + 256 * PEEK (ZZ(8) + 4):ZZ = PEEK (ZZ(8)
+ 2) - 31: IF ZZ > 1 THEN ZZ = ZZ - 3
740 ON ZZ GOTO 750,770,780
750 ZZ(7) = PEEK (25) + 256 * PEEK (26) - 2: POKE ZZ(7) + 2, PEEK (ZZ(9)
+ 2): POKE ZZ(7) + 3, PEEK (ZZ(9) + 3): POKE ZZ(7) + 4, PEEK (ZZ(9)
+ 4): POKE ZZ(7) + 5, PEEK (ZZ(9) + 5)
760 POKE ZZ(7) + 6, PEEK (ZZ(9) + 6): PRINT ZZ:; RETURN
770 ZZ(7) = PEEK (27) + 256 * PEEK (28) - 2: FOR ZZ = 2 TO 4: POKE ZZ(7)
+ ZZ, PEEK (ZZ(9) + ZZ): NEXT ZZ: PRINT LEFT$( ZZ$,14):; RETURN
780 ZZ(7) = PEEK (29) + 256 * PEEK (30) - 2: FOR ZZ = 2 TO 3: POKE ZZ(7)
+ ZZ, PEEK (ZZ(9) + ZZ): NEXT ZZ: PRINT ZZ$:; RETURN
790 IF ZZ = 209 THEN 830
800 HOME : PRINT : PRINT CHR$( 4);"BLOAD PAGE 0.SAVE": PRINT CHR$( 4);
"DELETE PAGE 0.SAVE": PRINT CHR$( 4)
810 PRINT CHR$( 4);"BLOAD PAGE 3.SAVE"
820 PRINT CHR$( 4);"DELETE PAGE 3.SAVE": PRINT CHR$( 4)
830 FOR ZZ = 32 TO 35: POKE ZZ, PEEK (715 + ZZ): NEXT ZZ
840 HOME : RETURN

```

]

```

0800      1 ;*****
0900      2 ;*
0900      3 ;* VARIABLE LISTER OBJ *
0900      4 ;* RICHARD ALBRIGHT *
0900      5 ;*
0800      6 ;*          LISTER *
0900      7 ;*
0800      8 ;* COPYRIGHT (C) 1982 *
0900      9 ;* MICRO INK, INC. *
0800     10 ;* CHELMSFORD, MA 01924 *
0900     11 ;* ALL RIGHTS RESERVED *
0800     12 ;*
0800     13 ;*****
0800     14 ;
00A5     15 VNAME   EPZ $A5      ;CURRENT VARIABLE NAME
00A8     16 VLOC   EPZ $A8      ;CURRENT VARIABLE LOCATION
00AA     17 VTYPE   EPZ $AA      ;VARIABLE TYPE (0=SIMPLE;1=ARR
AY)
00FD     18 NSIMPL  EPZ $FD      ;COUNT OF SIMPLE VARIABLES
00FE     19 NARRAY  EPZ $FE      ;COUNT OF ARRAY VARIABLES
0800     20 ;
0800     21 ;
0300     22          ORG $300
0300     23          OBJ $900
0300     24 ;
0300 A5 69 25          LDA $69      ;INITIALIZE VARIABLE POINTER T
0
0302 85 A8 26          STA VLOC      ;START OF SIMPLE VARIABLE
0304 A5 6A 27          LDA $6A      ;SPACE
0306 85 A9 28          STA VLOC+1
0308 A9 00 29          LDA #$00      ;INITIALIZE VARIABLE COUNTERS
030A 85 FD 30          STA NSIMPL   ;TO ZERO
030C 85 FE 31          STA NARRAY
030E 85 AA 32          STA VTYPE      ;START WITH SIMPLE VARIABLES
0310 A5 AA 33          LDA VTYPE      ;TOP OF MAIN LOOP
0312 18 34          CLC
0313 65 AA 35          ADC VTYPE      ;SET X TO 2 TIMES THE
0315 AA 36          TAX          ;VARIABLE INDEX
0316 A5 A9 37          LDA VLOC+1      ;IF CURRENT VARIABLE IS NOT
0318 D5 6C 38          CMP $6C,X      ;BEYOND THE END OF THE
031A 90 11 39          BCC STRTVP    ;STORAGE SPACE FOR THE
031C D0 06 40          BNE INCVT     ;CURRENT VARIABLE TYPE,
031E A5 A8 41          LDA VLOC      ;THEN GO ON TO VARIABLE
0320 D5 6B 42          CMP $6B,X      ;PROCESSING
0322 90 09 43          BCC STRTVP
0324 E6 AA 44          INC VTYPE      ;INCREMENT VARIABLE TYPE
0326 A4 AA 45          LDY VTYPE
0328 C0 02 46          CPY #$02
032A D0 E4 47          BNE TOP        ;GO BACK TO THE TOP IF INDEX<>
2
032C 60 48          RTS          ;QUIT IF INDEX=2
032D A6 AA 49          STRTVP     ;START OF VARIABLE PROCESSING
032F F6 FD 50          INC NSIMPL,X  ;INCREMENT VARIABLE COUNT
0331 A2 00 51          LDX #$00      ;BLANK OUT CURRENT VARIABLE
0333 A9 20 52          LDA #$20      ;NAME
0335 95 A5 53          BLNKVN     ;
0337 E8 54          STA VNAME,X
0338 E0 03 55          INX
033A D0 F9 56          CPX #$03
033C A0 00 57          BNE BLNKVN
033E B1 A8 58          LDY #$00      ;IF BIT 7 IS OFF, THEN
0340 C9 7F 59          LDA (VLOC),Y  ;SKIP INTEGER PROCESSING
0342 90 18 60          CMP #$7F
0344 A2 25 61          BCC SAVE1
0346 86 A7 62          LDX #$25      ;ATTACH '3' TO NAME
0348 29 7F 63          STX VNAME+2
034A 85 A5 64          AND #$7F      ;SAVE 1ST CHARACTER
034C C8 65          STA VNAME
R
034D B1 A8 66          INY          ;STRIP BIT 7 FROM 2ND CHARACTE
034F 29 7F 67          LDA (VLOC),Y  ;AND SAVE IF NOT $00
0351 C9 00 68          AND #$7F
0353 F0 1C 69          CMP #$00
0355 85 A6 70          BEQ LOWER
0357 18 71          STA VNAME+1
          CLC          ;SKIP STRING PROCESSING

```



```

0800      1 ;*****
0800      2 ;* *
0800      3 ;* SHELL-METZNER SORT *
0800      4 ;* RICHARD ALBRIGHT *
0800      5 ;* *
0800      6 ;* SORTER *
0800      7 ;* *
0800      8 ;* COPYRIGHT(C), 1982 *
0800      9 ;* MICRO INK, INC. *
0800     10 ;* CHELMSFORD, MA 01824 *
0800     11 ;* ALL RIGHTS RESERVED *
0800     12 ;* *
0800     13 ;*****
0800     14 ;
0800     15 ;
0019     16 RL EPZ $19 ;RECORD LENGTH
001A     17 KEYOFF EPZ $1A ;KEY OFFSET FROM START OF RECO
RD
001B     18 KEYLEN EPZ $1B ;KEY LENGTH
001C     19 N EPZ $1C ;NUMBER OF RECORDS IN $1C-$1D
001E     20 ARRAY EPZ $1E ;POINTER TO ARRAY IN $1E-$1F
00C9     21 KEYEND EPZ $C9 ;OFFSET OF LAST KEY BYTE
00CA     22 I EPZ $CA ;INDEX I IN $CA-$CB
00CC     23 L EPZ $CC ;INDEX L IN $CC-$CD
00CE     24 M EPZ $CE ;INDEX M IN $CE-$CF
00DA     25 K EPZ $DA ;INDEX K IN $DA-$DB
00DC     26 J EPZ $DC ;INDEX J IN $DC-$DD
00FA     27 CNT1 EPZ $FA ;TEMPORARY COUNTERS IN $FA-$FF

00FC     28 CNT2 EPZ $FC
00FE     29 CNT3 EPZ $FE
0800     30 ;
0300     31 ; ORG $300
0300     32 ; OBJ $800
0300     33 ;
0300 18   34 ; CLC ;ESTABLISH OFFSET OF LAST
0301 A5 1A 35 ; LDA KEYOFF ;KEY BYTE
0303 65 1B 36 ; ADC KEYLEN
0305 85 C9 37 ; STA KEYEND
0307 A5 1C 38 ; LDA N ;INITIALIZE M TO N
0309 85 CE 39 ; STA M
030B A5 1D 40 ; LDA N+1
030D 85 CF 41 ; STA M+1
030F 18   42 ; LOOP1 ;TOP OF MAIN LOOP
0310 66 CF 43 ; ROR M+1 ;M:=M/2
0312 66 CE 44 ; ROR M
0314 A5 CE 45 ; LDA M ;STOP IF M=0
0316 D0 05 46 ; BNE MORE
0318 A5 CF 47 ; LDA M+1
031A D0 01 48 ; BNE MORE
031C 60   49 ; RTS
031D A2 00 50 ; MORE LDX #$00 ;K:=N-M
031F 38   51 ; SEC
0320 A5 1C 52 ; LDA N
0322 E5 CE 53 ; SBC M
0324 85 DA 54 ; STA K
0326 A5 1D 55 ; LDA N+1
0328 E5 CF 56 ; SBC M+1
032A 85 DB 57 ; STA K+1
032C A9 01 58 ; LDA #$01 ;J:=1
032E 85 DC 59 ; STA J
0330 A9 00 60 ; LDA #$00
0332 85 DD 61 ; STA J+1
0334 A5 DC 62 ; LOOP2 ;I:=J
0336 85 CA 63 ; STA I
0338 A5 DD 64 ; LDA J+1
033A 85 CB 65 ; STA I+1
033C 18   66 ; LOOP3 ;L:=I+M
033D A5 CA 67 ; LDA I
033F 65 CE 68 ; ADC M
0341 85 CC 69 ; STA L
0343 A5 CB 70 ; LDA I+1
0345 65 CF 71 ; ADC M+1
0347 85 CD 72 ; STA L+1
0349 A2 00 73 ; LDX #$00 ;SET X REGISTER TO 0

```

```

034B A4 19      74  GETLOC  LDY RL          ;SET Y REGISTER TO RECORD LENG
TH
034D 38         75      SEC              ;INITIALIZE CNT2 TO I-1
034E B5 CA     76      LDA I,X          ;IF X=0
0350 E9 01     77      SBC #$01         ;INITIALIZE CNT3 TO L-1
0352 85 FA     78      STA CNT1         ;IF X=2
0354 95 FC     79      STA CNT2,X       ;AND STORE THE SAME
0356 B5 CB     80      LDA I+1,X       ;VALUE IN CNT1
0358 E9 00     81      SBC #$00
035A 85 FB     82      STA CNT1+1
035C 95 FD     83      STA CNT2+1,X
035E 88        84  GETOFF  DEY              ;MULTIPLY BY RECORD LENGTH TO
035F F0 16     85      BEQ GETABS       ;GET THE OFFSET OF THE
0361 18        86      CLC              ;(I-1)TH RECORD (IF X=0) OR TH
E
0362 A5 FA     87      LDA CNT1         ;(L-1)TH RECORD (IF X=2) FROM
0364 75 FC     88      ADC CNT2,X       ;THE START OF THE ARRAY
0366 95 FC     89      STA CNT2,X
0368 A5 FB     90      LDA CNT1+1
036A 75 FD     91      ADC CNT2+1,X
036C 95 FD     92      STA CNT2+1,X
036E 90 EE     93      BCC GETOFF
0370 00        94      BRK              ;BREAK ON OVERFLOW
0371 D0 C9     95  RELAY3  BNE LOOP3       ;RELAY RETURNS
0373 90 BF     96  RELAY2  BCC LOOP2
0375 D0 98     97  RELAY1  BNE LOOP1
0377 18        98  GETABS  CLC              ;ADD LOCATION OF START
0378 A5 1E     99      LDA ARRAY       ;OF ARRAY TO GET ABSOLUTE
037A 75 FC    100     ADC CNT2,X       ;LOCATION OF (I-1)TH OR
037C 95 FC    101     STA CNT2,X       ;(L-1)TH RECORD
037E A5 1F    102     LDA ARRAY+1
0380 75 FD    103     ADC CNT2+1,X
0382 95 FD    104     STA CNT2+1,X
0384 E8        105     INX              ;ADD 2 TO X REGISTER
0385 E8        106     INX
0386 E0 04    107     CPX #$04         ;GO GET (L-1)TH RECORD
0388 D0 C1    108     BNE GETLOC       ;IF X=2
038A A4 1A    109     LDY KEYOFF       ;SET Y REGISTER TO KEY OFFSET
038C B1 FC    110     COMPAR  LDA (CNT2),Y  ;COMPARE (I-1)TH AND
038E D1 FE    111     CMP (CNT3),Y   ;(L-1)TH KEY VALUES;
0390 90 09    112     BCC SWITCH     ;SWITCH RECORDS IF THE
0392 D0 2F    113     BNE INCJ       ;(L-1)TH KEY IS > THE
0394 C8        114     INY              ;(I-1)TH KEY
0395 C4 C9    115     CPY KEYEND
0397 D0 F3    116     BNE COMPAR
0399 F0 28    117     BEQ INCJ
039B A4 19    118     SWITCH  LDY RL
039D 88        119     SW1    DEY
039E B1 FC    120     LDA (CNT2),Y
03A0 AA        121     TAX
03A1 B1 FE    122     LDA (CNT3),Y
03A3 91 FC    123     STA (CNT2),Y
03A5 8A        124     TXA
03A6 91 FE    125     STA (CNT3),Y
03A8 C0 00    126     CPY #$00
03AA D0 F1    127     BNE SW1
03AC 38        128     SEC              ;I:=I-M
03AD A5 CA    129     LDA I
03AF E5 CE    130     SBC M
03B1 85 CA    131     STA I
03B3 A5 CB    132     LDA I+1
03B5 E5 CF    133     SBC M+1
03B7 85 CB    134     STA I+1
03B9 A5 CB    135     LDA I+1         ;BRANCH ON I<1
03BB 30 06    136     BMI INCJ
03BD D0 B2    137     BNE RELAY3

03BF A5 CA    138     LDA I
03C1 D0 AE    139     BNE RELAY3
03C3 E6 DC    140     INCJ    INC J          ;J:=J+1
03C5 D0 02    141     BNE INCJ2
03C7 E6 DD    142     INC J+1
03C9 A5 DD    143     INCJ2   LDA J+1         ;BRANCH ON J>K
03CB C5 DB    144     CMP K+1

```

03CD 90 A4	145	BCC RELAY2
03CF D0 A4	146	BNE RELAY1
03D1 A5 DC	147	LDA J
03D3 C5 DA	148	CMP K
03D5 90 9C	149	BCC RELAY2
03D7 18	150	CLC
03D8 F0 99	151	BEQ RELAY2
03DA D0 99	152	BNE RELAY1
03DC	153	END

SYMBOL TABLE SORTED ALPHABETICALLY

ARRAY	001E	CNT1	00FA	CNT2	00FC	CNT3	00FE	COMPAR	038B
GETABS	0376	GETLOC	034B	GETOFF	035E	I	00CA	INCJ	03C2
INCJ2	03C8	J	00EB	K	00D6	KEYEND	00C9	KEYLEN	001B
KEYOFF	001A	L	00CC	LOOP1	030F	LOOP2	0334	LOOP3	033C
M	00CE	MORE	031D	N	001C	RELAY1	0374	RELAY2	0372
RELAY3	0370	RL	0019	SW1	039C	SWITCH	039A		

SYMBOL TABLE SORTED BY ADDRESS

RL	0019	KEYOFF	001A	KEYLEN	001B	N	001C	ARRAY	001E
KEYEND	00C9	I	00CA	L	00CC	M	00CE	K	00D6
J	00EB	CNT1	00FA	CNT2	00FC	CNT3	00FE	LOOP1	030F
MORE	031D	LOOP2	0334	LOOP3	033C	GETLOC	034B	GETOFF	035E
RELAY3	0370	RELAY2	0372	RELAY1	0374	GETABS	0376	COMPAR	038B
SWITCH	039A	SW1	039C	INCJ	03C2	INCJ2	03C8		

2

MACHINE-LANGUAGE AIDS

Double Barrelled Disassembler <i>David L. Rosenberg</i>	39
Cross Referencing 6502 Programs <i>Cornelis Bongers</i>	48
A Fast Fractional Math Package for 6502 Microcomputers <i>Wes Huntress</i>	65
Applesoft Error Messages from Machine Language <i>Steve Cochard</i>	84

Machine-Language Aids

This chapter contains four utility programs designed to make life a little easier for the assembly-language programmer.

David Rosenberg's "Double Barrelled Disassembler" not only prints a hard copy disassembly two abreast, but also gives the user the ability to specify a precise range of memory without disassembling in increments of 20 instructions. "Cross Referencing 6502 Programs" by Cornelis Bongers is an indispensable tool for anyone interested in analyzing code through disassembly. With this program the user can study all address references within a range of code, either external or internal.

Wes Huntress's "Fast Fractional Math Package" provides the assembly language programmer with a tool bag of fractional math functions. For the BASIC programmer, it gives Integer BASIC the ability to perform complex functions and speeds up Applesoft at the cost of some accuracy. "Applesoft Error Messages from Machine Language" by Steve Cochard describes how to access Applesoft error messages from machine language and offers programming examples on interfacing with error message subroutines.

Double Barrelled Disassembler

by David L. Rosenberg

This short utility makes it easier to create disassembly listings. It not only lists from starting to ending addresses, but also formats the listing into two columns for easier reading and less paper usage.

How many L's are there between \$BD00 and \$BFFF? What seems at first to be a ridiculous question actually points out one of the few flaws in the Apple II's ROM Monitor: the disassembler routine only prints twenty lines at a time. This can be a major annoyance if you are printing many long listings.

This program attacks the problem and formats the listing into two columns to minimize wasted paper and make the disassembly easier to follow. Once the program has been BRUN the disassembly function is called by typing "beginning address"."ending address" (CTRL - Y) return. This sequence will disassemble the code from the beginning address through the ending address and print it in two column per page format (see listing 1).

How Does it Work?

The program divides the first part of the object code into two segments, each containing the same number of instructions as there are lines on a page. Then it takes one instruction from each piece and calls the Monitor disassembly routine to print them on the same line. Next, the pointers to the instructions are incremented and the program loops to the disassembly portion again. When all the instructions in each segment are done, a form-feed is printed and the next portion of the code is segmented, and the process is repeated until the ending address is reached.

The only problem I encountered was that the Monitor disassembly routine prints a carriage return as the first character each time it is called. Obviously this is not desirable after we go to the trouble of positioning the printer to the start of the second column. To circumvent this the disassembler is called in four separate pieces.

PR1 is called to print the address in the Program Counter (\$3A,\$3B) as four ASCII bytes followed by a dash. PR2 points PC at the length of the instruction and forms an index into the Monitor's op-code mnemonic table. PR3 actually prints the mnemonic along with the appropriate address or hex literal. At this point we must push a \$01 onto the stack to indicate that this is the last instruction to disassemble. PR4 increments PC to point to the next instruction then pulls the top value from the stack, decrements it by one and if it is equal to zero, does a return. Since PR4 is jumped to, this return will take us back to the mainline where the program sets up to disassemble the corresponding instruction from column two.

Before calling the Monitor disassembler, PC must contain the address of the instruction to be disassembled. Since we are disassembling and printing two non-sequential instructions on each line, a large part of the program is concerned with swapping instruction addresses in and out of PC. A4 (\$42,\$43) is used as a work byte to store the column one address when the second column is being disassembled. A3 (\$40,\$41) serves a similar function when the first column is being disassembled. A2 (\$3E,\$3F) always contains the ending address of the code to be disassembled.

The subroutine INITA3 calls a Monitor routine at \$F88E to return the length of an instruction. The whole purpose of the routine is to find the address of the n th + 1 instruction, where n is the number of lines per page. This is also the start of column two, so we want this address to wind up in A3. To accomplish this we will call INSDS2 n times and add the resulting length to the address at A3. Note that the length returned is actually one less than the actual instruction length, and therefore, we must increment LEN before adding it to A3. Invalid op-codes are not flagged, but are returned as one-byte length instructions.

To end execution, routine CMPCA2 compares the current value of PC to the value of A2 (the end address). If it is equal to, or greater than A2, we pop the last return address from the stack and jump to UNHOOK. This effectively disconnects from the mainline and resets the stack to the condition it was at when the disassembler was first invoked. Because the program is called from monitor, the RTS in UNHOOK will result in a return to monitor.

Making it Work

This program should be used with an AIO serial card in slot #1 and a Texas Instruments 810 printer. The routine STHOOK sets the DOS output hooks and disables the serial card's video echo. If your interface is in a different slot, change the LDX instruction at line 89. It is of the format Cn , where n is the slot number. For printers with a software-selectable line width this would be the best place to include the code for this function. The routine UNHOOK, always the last one executed, is where you should reset the line width.

The first instruction in the routine TAB controls how far over (in print positions) the second column will start. This can be changed to $\frac{1}{2}$ of the line width that you are using (i.e., \$28 for an 80-column line). The number of lines per page is set in two places, line 118 and line 177. It can be set to suit your needs, but just be sure it is the same in both places.

If your printer does not recognize \$0C as a form-feed character or does not have a formfeed, the routine FFE ED will have to be changed. This routine makes the printer skip to the top of the next page.

Since the program uses standard Apple output routines it can be used, as is, with any printer card (serial or parallel) that does not require a software driver. If you use a print driver routine, change the JSRs at lines 66, 79, 85 and 93 to go to your driver entry point. The character to be printed will reside in the Accumulator prior to these calls.

Editor's note: Listing 2 is an example of how the Double Barrelled Disassembler can be modified for other card/printer combinations. Here the program was modified to work with Apple's serial Interface Card and a Bedford Computer Systems, Inc., daisy wheel printer.

Listing 1

```

0800      1 ;*****
0800      2 ;*
0800      3 ;*   DOUBLE BARRELLED   *
0800      4 ;*   DISASSEMBLER     *
0800      5 ;*         BY           *
0800      6 ;*   DAVID L. ROSENBURG *
0800      7 ;*
0800      8 ;*         DISSASMB     *
0800      9 ;*
0800     10 ;*   COPYRIGHT (C) 1982  *
0800     11 ;*   MICRO INK, INC.    *
0800     12 ;*   CHELMSFORD, MA 01824 *
0800     13 ;*   ALL RIGHTS RESERVED *
0800     14 ;*
0800     15 ;*****
0800     16 ;
0800     17 ;
0024     18 CH      EPZ $24      ;CURSOR HORIZONTAL POSN
002F     19 LEN     EPZ $2F      ;INSTRUCTION LENGTH
003A     20 PC      EPZ $3A      ;ADDRESS TO DISSASSEMBLE
003E     21 A2      EPZ $3E      ;ENDING ADDRESS
0040     22 A3      EPZ $40      ;ADDRESS TO DISSASSEMBLE
0042     23 A4      EPZ $42      ;WORK BYTE
0045     24 A5      EPZ $45      ;LINE COUNTER
03F8     25 VECTOR EQU $3F8     ;CTRL-Y VECTOR ADDRESS
0579     26 NOVID  EQU $579     ;AIO SERIAL CARD NOVID FLG
05F9     27 COL    EQU $5F9     ;SERIAL INTER. CARD COLUMN NO.
06F9     28 PWDTH EQU $6F9     ;SERIAL INTER. CARD LINE WIDTH
AA53     29 HOOKS  EQU $AA53     ;OUTPUT HOOK
F88E     30 INSDS2 EQU $F88E     ;ROUTINE FOR INSTRUC. LENGTH
FD8D     31 PRINT  EQU $FD8D     ;MONITOR COUT ROUTINE
FD99     32 PR1   EQU $FD99     ;PART OF DISSASSEMBLER (ROM)
F889     33 PR2   EQU $F889     ;PART OR DISSASSEMBLER (ROM)
F8D3     34 PR3   EQU $F8D3     ;PART OF DISSASSEMBLER (ROM)
FE67     35 PR4   EQU $FE67     ;PART OF DISSASSEMBLER (ROM)
0800     36 ;
0800     37          ORG $800
0800     38 ;
0800     39 ;*****
0800     40 ;THIS ROUTINE SETS THE APPLE'S CTRL-Y VECTOR ADDRESS
0800     41 ;TO POINT TO THE START OF THE DISSASSEMBLER CODE
0800     42 ;IT IS EXECUTED WHEN THE PROGRAM IS BRUN
0800     43 ;*****
0800     44 ;
0800 A9 4C     45 INIT   LDA #$4C      ;OP CODE FOR JUMP
0802 8D F8 03 46          STA VECTOR      ;STORE AT CTRL-Y VECTOR
0805 A9 10     47          LDA $START     ;GET LOW BYTE OF ENTRY LOCATIO
N
0807 8D F9 03 48          STA VECTOR+1    ;STORE AT VECTOR
080A A9 08     49          LDA /$START     ;GET HI BYTE OF ENTRY LOCATION

080C 8D FA 03 50          STA VECTOR+2    ;STORE AT VECTOR
080F 60       51          RTS
0810         52 ;
0810         53 ;*****
0810         54 ;   START OF DISSASSEMBLER
0810         55 ;*****
0810         56 ;
0810 20 62 08 57 START  JSR $HOOK      ;SET OUTPUT HOOKS FOR PRINTER
0813 20 87 08 58 MAIN   JSR $SETPC     ;SET PC TO A3
0816 20 99 08 59          JSR $SETA5     ;SET A5 TO # OF LINES PER PAGE

0819 20 E9 08 60          JSR $INITA3    ;SET A3 TO START OF COLUMN 2
081C 20 9E 08 61 LOOP   JSR $CMPCA2   ;COMPARE PC TO END ADDRESS
081F 20 D6 08 62          JSR $DISASM    ;DISSASSEMBLE INSTRUCTION AT PC

0822 20 B7 08 63          JSR $CMA3A2    ;COMPARE A3 TO END ADDRESS
0825 B0 12     64          RCS $LOOP2     ;DON'T PRINT 2ND COLUMN IF >
0827 20 C4 08 65          JSR $STORPC    ;SAVE PC AT A4
082A 20 87 08 66          JSR $SETPC     ;SET PC TO A3
082D 20 48 08 67          JSR $TAB
0830 20 D6 08 68          JSR $DISASM    ;DISSASSEMBLE INSTRUCTION AT PC
(=A3)

```

```

0833 20 90 08      69          JSR SETA3          ;SET A3 TO PC
0836 20 CD 08      70          JSR RSTRPC        ;SET PC TO A4
0839 A9 0D          71  LOOP2      LDA #S0D
083B 20 ED FD      72          JSR PRINT         ;PRINT CARRIAGE RETURN
083E C6 45          73          DEC A5           ;DECREMENT LINE COUNTER
0840 D0 DA          74          BNE LOOP        ;IF NOT END OF PAGE
0842 20 5C 08      75          JSR FFEED        ;ADVANCE TO NEXT PAGE
0845 4C 13 08      76          JMP MAIN
0848 A9 42          77  TAB        LDA #$42
084A 38            78          SEC
084B E5 24          79          SBC CH
084D AA            80          TAX
084E F0 0B          81  T1        BEQ TX
0850 30 09          82          BMI TX
0852 A9 A0          83          LDA #S0A0
0854 20 ED FD      84          JSR PRINT         ;PRINT SPACES TILL
0857 CA            85          DEX
0858 4C 4E 08      86          JMP T1           ;X-REG=0
085B 60            87  TX        RTS
085C A9 0C          88          LDA #S0C
085E 20 ED FD      89          JSR PRINT         ;PRINT FORM FEED
0861 60            90          RTS
0862 A0 00          91  STHOOK     LDY #S00
0864 A2 C1          92          LDX #S0C1
0866 8E 54 AA      93          STX 400KS+1
0869 8C 53 AA      94          STY 400KS
086C A9 8D          95          LDA #S8D
086E 20 ED FD      96          JSR PRINT         ;PRINT CARRIAGE RETURN TO
0871 A9 80          97          LDA #S80
0873 8D 79 05      98          STA NOVID
0876 60            99          RTS
0877 A9 00          100 UNHOOK     LDA #S00
0879 A0 F0          101          LDY #S0F0
087B A2 FD          102          LDX #S0FD
087D 8D 79 05      103          STA NOVID
0880 8C 53 AA      104          STY 400KS
0883 8E 54 AA      105          STX 400KS+1
0886 60            106          RTS
0887 A5 40          107          SETPC     LDA A3
0889 85 3A          108          STA PC
088B A5 41          109          LDA A3+1
088D 85 3B          110          STA PC+1
088F 60            111          RTS
0890 A5 3A          112          SETA3     LDA PC
0892 85 40          113          STA A3
0894 A5 3B          114          LDA PC+1
0896 85 41          115          STA A3+1
0898 60            116          RTS
0899 A9 3C          117          SETA5     LDA #S3C
089B 85 45          118          STA A5
089D 60            119          RTS
089E A5 3B          120          CMPCA2    LDA PC+1
08A0 C5 3F          121          CMP A2+1
08A2 90 12          122          BCC C2
08A4 F0 05          123          BEQ C1
08A6 68            124          PLA
08A7 68            125          PLA
08A8 4C 77 08      126          JMP UNHOOK
08AB A5 3A          127          C1        LDA PC
08AD C5 3E          128          CMP A2
08AF 90 05          129          BCC C2
08B1 68            130          PLA
08B2 68            131          PLA
08B3 4C 77 08      132          JMP UNHOOK
08B6 60            133          C2        RTS
08B7 A5 41          134          CMA3A2   LDA A3+1
08B9 C5 3F          135          CMP A2+1
08BB 90 06          136          BCC CMA2
08BD D0 04          137          BNE CMA2
08BF A5 40          138          LDA A3
08C1 C5 3E          139          CMP A2
08C3 60            140          CMA2     RTS
08C4 A5 3A          141          STORPC    LDA PC
08C6 85 42          142          STA A4
08C8 A5 3B          143          LDA PC+1
;SAVE CURRENT VALUE OF PC

```

44 Machine-Language Aids

```

08CA 85 43      144      STA A4+1
08CC 60         145      RTS
08CD A5 42      146  RSTRPC LDA A4          ;RESTORE PC FROM CURRENT
08CF 85 3A      147      STA PC          ;VALUE OF A4
08D1 A5 43      148      LDA A4+1
08D3 85 3B      149      STA PC+1
08D5 60         150      RTS
08D6 A6 3A      151  DISASM LDX PC          ;DISASSEMBLE 1 INSTRUCTION
08D8 A4 3B      152      LDY PC+1      ;AT PC USING MONITOR
08DA 20 99 FD    153      JSR PR1       ;DISASSEMBLE ROUTINE
08DD 20 89 F8    154      JSR PR2       ;IN FOUR PARTS
08E0 20 D3 F8    155      JSR PR3
08E3 A9 01      156      LDA #$01      ;SET COUNTER ON STACK FOR
08E5 48         157      PHA          ;NUMBER OF INSTRUCTIONS
08E6 4C 67 FE    158      JMP PR4       ;ROUTINE SUPPLIES RTS
08E9           159      ;
08E9           160      ;*****
08E9           161      ;THIS ROUTINE CALCULATES THE ADDRESS OF THE
08E9           162      ;FIRST INSTRUCTION IN COLUMN TWO
08E9           163      ;*****
08E9           164      ;
08E9 A2 3C      165  INITA3 LDX #$3C      ;NUMBER OF INSTRUCTIONS
08EB A0 00      166  INIT41 LDY #$00      ;SET INDEX POINTER
08ED 8A         167      TXA          ;SAVE NUMBER OF
08EE 48         168      PHA          ;INSTRUCTIONS ON STACK
08EF B1 40      169      LDA (A3),Y     ;GET OP CODE
08F1 20 8E F8    170      JSR INSDS2    ;MONITOR ROUTINE FOR LENGTH
08F4 E6 2F      171      INC LEN
08F6 A5 40      172      LDA A3          ;GET A3 AND
08F8 18         173      CLC          ;INCREMENT BY
08F9 65 2F      174      ADC LEN      ;LENGTH OF INSTRUCTION
08FB 85 40      175      STA A3          ;SAVE IN A3
08FD 90 02      176      BCC INIT42    ;INCREMENT HI BYTE
08FF E6 41      177      INC A3+1     ;IF NECESSARY
0901 68         178  INIT42 PLA          ;GET NUMBER OF INSTRUCTIONS
0902 AA         179      TAX
0903 CA         180      DEX
0904 D0 E5      181      BNE INIT41    ;SUBTRACT 1
0906 60         182      RTS          ;LOOP IF NOT DONE
0907           183      END

```

Listing 2

```

0800      1 ;*****
0800      2 ;*
0800      3 ;*   DOUBLE BARRELLED   *
0800      4 ;*   DISASSEMBLER     *
0800      5 ;*   BY                 *
0800      6 ;*   DAVID L. ROSENBERG *
0800      7 ;*
0800      8 ;*   MODIFIED BY T.S.O.  *
0800      9 ;*   TO WORK WITH      *
0800     10 ;*   THE APPLE SERIAL *
0800     11 ;*   INTERFACE CARD   *
0800     12 ;*
0800     13 ;*   DISASSMB-SC       *
0800     14 ;*
0800     15 ;*   COPYRIGHT (C) 1982 *
0800     16 ;*   MICRO INK, INC.  *
0800     17 ;*   CHELMSFORD, MA 01824 *
0800     18 ;*   ALL RIGHTS RESERVED *
0800     19 ;*
0800     20 ;*****
0800     21 ;
0024     23 CH      EPZ $24      ;CURSOR HORIZONTAL POSN
002F     24 LEN      EPZ $2F      ;INSTRUCTION LENGTH
003A     25 PC      EPZ $3A      ;ADDRESS TO DISASSEMBLE
003E     26 A2      EPZ $3E      ;ENDING ADDRESS
0040     27 A3      EPZ $40      ;ADDRESS TO DISASSEMBLE
0042     28 A4      EPZ $42      ;WORK BYTE
0045     29 A5      EPZ $45      ;LINE COUNTER
03F8     30 VECTOR  EQU $3F8      ;CTRL-Y VECTOR ADDRESS
0579     31 NOVID   EQU $579      ;AIO SERIAL CARD NOVID FLG
05F9     32 COL      EQU $5F9      ;SERIAL INTER. CARD COLUMN NO.

06F9     33 PWDTH   EQU $6F9      ;SERIAL INTER. CARD LINE WIDTH

AA53     34 HOOKS    EQU $AA53      ;OUTPUT HOOK
F88E     35 INSDS2   EQU $F88E      ;ROUTINE FOR INSTRUC. LENGTH
FDED     36 PRINT    EQU $FDED      ;MONITOR COUT ROUTINE
FD99     37 PR1     EQU $FD99      ;PART OF DISASSEMBLER (ROM)
F889     38 PR2     EQU $F889      ;PART OR DISASSEMBLER (ROM)
F8D3     39 PR3     EQU $F8D3      ;PART OF DISASSEMBLER (ROM)
FE67     40 PR4     EQU $FE67      ;PART OF DISASSEMBLER (ROM)
0800     41 ;
0800     42          ORG $800
0800     43 ;
0800     44 ;*****
0800     45 ;THIS ROUTINE SETS THE APPLE'S CTRL-Y VECTOR ADDRESS
0800     46 ;TO POINT TO THE START OF THE DISASSEMBLER CODE
0800     47 ;IT IS EXECUTED WHEN THE PROGRAM IS BRUN
0800     48 ;*****
0800     49 ;
0800 A9 4C     50 INIT     LDA #S4C      ;OP CODE FOR JUMP
0802 8D F8 03 51          STA VECTOR      ;STORE AT CTRL-Y VECTOR
0805 A9 10     52          LDA #START      ;GET LOW BYTE OF ENTRY LOCATIO
N
0807 8D F9 03 53          STA VECTOR+1      ;STORE AT VECTOR
080A A9 08     54          LDA /START      ;GET 4I BYTE OF ENTRY LOCATION

080C 8D FA 03 55          STA VECTOR+2
080F 60       56          RTS
0810       57 ;
0810       58 ;*****
0810       59 ;   START OF DISASSEMBLER
0810       60 ;*****
0810       61 ;
0810 20 71 08 62 START   JSR STHOOK      ;SET OUTPUT HOOKS FOR PRINTER
0813 20 96 08 63 MAIN    JSR SETPC      ;SET PC TO A3
0816 20 A8 08 64          JSR SETA5      ;SET A5 TO # OF LINES PER PAGE

0819 20 F8 08 65          JSR INITA3      ;SET A3 TO START OF COLUMN 2
081C 20 AD 08 66 LOOP    JSR CMPCA2      ;COMPARE PC TO END ADDRESS
081F 20 E5 08 67          JSR DISASM      ;DISASSEMBLE INSTRUCTION AT PC

0822 20 C6 08 68          JSR CMA3A2      ;COMPARE A3 TO END ADDRESS

```

46 Machine-Language Aids

```

0825 B0 12      69      BCS LOOP2      ;DON'T PRINT 2ND COLUMN IF >
0827 20 D3 08  70      JSR STORPC     ;SAVE PC AT A4
082A 20 96 08  71      JSR SETPC     ;SET PC TO A3
082D 20 52 08  72      JSR TAB
0830 20 E5 08  73      JSR DISASM    ;DISASSEMBLE INSTRUCTION AT
                                PC (=A3)
0833 20 9F 08  74      JSR SETA3     ;SET A3 TO PC
0836 20 DC 08  75      JSR RSTRPC    ;SET PC TO A4
0839 A9 0D      76      LOOP2   LDA #S0D
083B 20 ED FD  77      JSR PRINT    ;PRINT CARRIAGE RETURN
083E A9 0A      78      LDA #S0A
0840 20 ED FD  79      JSR PRINT    ;PRINT LINE FEED
0843 A9 00      80      LDA #S00
0845 8D F9 05  81      STA COL      ;RESET COLUMN PARAMETER
0848 C6 45      82      DEC A5       ;DECREMENT LINE COUNTER
084A D0 D0      83      BNE LOOP    ;IF NOT END OF PAGE
084C 20 6B 08  84      JSR FFEED   ;ADVANCE TO NEXT PAGE
084F 4C 13 08  85      JMP MAIN
0852 AD F9 05  86      TAB     LDA COL      ;GET COLUMN FROM SERIAL CARD
0855 85 24      87      STA C4
0857 A9 42      88      LDA #S42
0859 38         89      SEC
085A E5 24      90      SBC C4
085C AA         91      TAX
085D F0 0B      92      T1     BEQ TX
085F 30 09      93      BMI TX
0861 A9 A0      94      LDA #SA0
0863 20 ED FD  95      JSR PRINT    ;PRINT SPACES TILL
0866 CA         96      DEX
                                ;X-REG=0
0867 4C 5D 08  97      JMP T1
086A 60         98      TX     RTS
086B A9 0C      99      FFEED   LDA #S0C    ;PRINT FORM FEED
086D 20 ED FD  100     JSR PRINT
0870 60         101     RTS
0871 A0 00      102     STHOOK  LDY #S00    ;SET THE OUTPUT HOOK
0873 A2 C1      103     LDX #S01    ;TO C100 (SLOT 1)
0875 8E 54 AA  104     STX HOOKS+1
0878 8C 53 AA  105     STY HOOKS
087B A9 8D      106     LDA #S8D    ;PRINT CARRIAGE RETURN TO
087D 20 ED FD  107     JSR PRINT    ;INITIALIZE SERIAL CARD
0880 20 ED FD  108     JSR PRINT
0883           109     ;     LDA #S80
0883           110     ;     STA NOVID
                                ;NO VIDEO MOD
0883 A9 00      111     ;     LDA #S00
                                ;SHUT OFF FORCED CR'S
0885 8D F9 06  112     ;     STA PWDTH
                                ;FROM SERIAL CARD
0888 60         113     RTS
0889 A9 00      114     UNHOOK  LDA #S00    ;RESET VIDEO MOD
088B A0 F0      115     LDY #S00    ;AND RESTORE OUTPUT
088D A2 FD      116     LDX #SFD    ;HOOKS TO SCREEN
088F           117     ;     STA NOVID
088F 8C 53 AA  118     STY HOOKS
0892 8E 54 AA  119     STX HOOKS+1
0895 60         120     RTS
0896 A5 40      121     SETPC   LDA A3      ;SET PC TO A3
0898 85 3A      122     STA PC
089A A5 41      123     LDA A3+1
089C 85 3B      124     STA PC+1
089E 60         125     RTS
089F A5 3A      126     SETA3   LDA PC      ;SET A3 TO PC
08A1 85 40      127     STA A3
08A3 A5 3B      128     LDA PC+1
08A5 85 41      129     STA A3+1
08A7 60         130     RTS
08A8 A9 3C      131     SETA5   LDA #S3C    ;INITIALIZE LINE COUNTER TO
08AA 85 45      132     STA A5
                                ;60 --- COUNTS DOWN
08AC 60         133     RTS
08AD A5 3B      134     CMPCA2  LDA PC+1    ;COMPARE HI BYTE OF PC TO
08AF C5 3F      135     CMP A2+1   ;HI BYTE OF A2 (END ADDR)
08B1 90 12      136     BCC C2     ;RETURN
08B3 F0 05      137     BEQ C1     ;=COMPARE LOW BYTES

08B5 68         138     PLA
                                ;POP RETURN ADDRESS
08B6 68         139     PLA
                                ;OFF THE STACK
08B7 4C 89 08  140     JMP UNHOOK ;RESET HOOKS AND QUIT
08BA A5 3A      141     C1     LDA PC
                                ;COMPARE LOW BYTES

```

```

08BC C5 3E      142      CMP A2
08BE 90 05      143      BCC C2          ;RETURN
08C0 68         144      PLA           ;POP STACK
08C1 68         145      PLA
08C2 4C 89 08   146      JMP UNHOOK     ;RESET AND QUIT
08C5 60         147      C2            RTS
08C6 A5 41      148      CMA3A2       LDA A3+1       ;COMPARE A3 AND A2
08C8 C5 3F      149      CMP A2+1     ;RETURN WITH CARRY BIT
08CA 90 06      150      BCC CMA2     ;SET OR CLEAR TO
08CC D0 04      151      BNE CMA2     ;INDICATE STATUS
08CE A5 40      152      LDA A3
08D0 C5 3E      153      CMP A2
08D2 60         154      CMA2        RTS
08D3 A5 3A      155      STORPC      LDA PC
08D5 85 42      156      STA A4          ;SAVE CURRENT VALUE OF PC
08D7 A5 3B      157      LDA PC+1
08D9 85 43      158      STA A4+1
08DB 60         159      RTS
08DC A5 42      160      RSTRPC      LDA A4          ;RESTORE PC FROM CURRENT
08DE 85 3A      161      STA PC          ;VALUE OF A4
08E0 A5 43      162      LDA A4+1
08E2 85 3B      163      STA PC+1
08E4 60         164      RTS
08E5 A6 3A      165      DISASM      LDX PC          ;DISASSEMBLE 1 INSTRUCTION
08E7 A4 3B      166      LDY PC+1       ;AT PC USING MONITOR
08E9 20 99 FD   167      JSR PR1        ;DISASSEMBLE ROUTINE
08EC 20 89 F8   168      JSR PR2        ;IN FOUR PARTS
08EF 20 D3 F8   169      JSR PR3
08F2 A9 01      170      LDA #S01       ;SET COUNTER ON STACK FOR
08F4 48         171      PHA           ;NUMBER OF INSTRUCTIONS
08F5 4C 67 FE   172      JMP PR4        ;ROUTINE SUPPLIES RTS
08F8           173      ;
08F8           174      ;*****
08F8           175      ;THIS ROUTINE CALCULATES THE ADDRESS OF THE
08F8           176      ;FIRST INSTRUCTION IN COLUMN TWO
08F8           177      ;*****
08F8           178      ;
08F8 A2 3C      179      INITA3      LDX #S3C       ;NUMBER OF INSTRUCTIONS
08FA A0 00      180      INIT41      LDY #S00       ;SET INDEX POINTER
08FC 8A         181      TXA           ;SAVE NUMBER OF
08FD 48         182      PHA           ;INSTRUCTIONS ON STACK
08FE B1 40      183      LDA (A3),Y    ;GET OP CODE
0900 20 8E F8   184      JSR INSDS2    ;MONITOR ROUTINE FOR LENGTH
0903 E6 2F      185      INC LEN
0905 A5 40      186      LDA A3          ;GET A3 AND
0907 18         187      CLC           ;INCREMENT BY
0908 65 2F      188      ADC LEN       ;LENGTH OF INSTRUCTION
090A 85 40      189      STA A3          ;SAVE IN A3
090C 90 02      190      BCC INIT42    ;INCREMENT HI BYTE
090E E6 41      191      INC A3+1     ;IF NECESSARY
0910 68         192      INIT42     PLA           ;GET NUMBER OF INSTRUCTIONS
0911 AA         193      TAX
0912 CA         194      DEX
0913 D0 E5      195      BNE INIT41    ;SUBTRACT 1
0915 60         196      RTS          ;LOOP IF NOT DONE
0916           197      END

```

Cross Referencing 6502 Programs

by Cornelis Bongers

This cross reference program facilitates the analysis of 6502 programs by constructing a cross reference table that relates each address that is used to its point of reference.

The variety and quality of software for 6502 systems continues to grow. Now it is not attractive to write certain programs yourself, such as a word processor or advanced game, since the market offers most programs of this kind at reasonable prices. However, there is one flaw in this argument. After you buy a program, you almost always discover that it would have suited your needs if those two (missing) options had been included, or if that nasty bug had been left out.

An example is the flight simulator, a well-known program to Apple owners. The first time I tried to hold that plane in the air while keeping the Germans off my tail, it all seemed very difficult, even impossible. However, after many (entertaining) hours, I finally mastered the game. Then I wondered why there wasn't a second level of play — one for aces. For instance, in the latter version, a restriction could be put on the vertical velocity when the plane is landing. In the current version you land safely, whatever the vertical speed. A plane crash would be more realistic if the vertical velocity exceeds a certain speed at the moment of touchdown.

If you're satisfied with a program except for a few points, you have three options: 1. Do nothing and just live with it. If this is your choice, stop reading and skip the rest of this article. 2. Write your own program and include the missing options while omitting the bugs. However, this decision will not in general be very wise because it will cost you at least a few months (probably much longer) to write. 3. Analyze the program you have and build in the extra options with patches. As you'll see, the crucial part is the analysis of the program. A cross reference table is useful for this, and although it doesn't answer all questions, it saves hours of work on Applesoft analysis.

Analyzing Programs

I will describe some of the experiences I had during the analysis of Applesoft. Since I knew Applesoft started at \$E000, I started analyzing at \$E000 too. I kept track of all zero page addresses that were used and the values that were stored in them. I also made a list of the called subroutines. Soon I discovered that this process would drive me crazy. After several hours of working, I had a zero page table full of meaningless numbers, not to mention an enormous table of subroutines that were called for unknown reasons.

Just before I decided to give up, I remembered something an experienced programmer once told me: a large program somehow has to analyze its input and thus must have a keyword table. Furthermore, large programs usually contain a number of subroutines which handle the keyword functions. Since keywords can be recognized in a disassembly listing by repeated question marks, I found the keyword table of Applesoft. Because program control must go to a routine handling the keyword function when a keyword is detected, it seemed logical that there also had to be a table of subroutine entry addresses.

After scanning through the listing, I found this table right before the keyword table. A few hours later I had the subroutine entries in the listing marked with the keywords and called it a day, thinking that the rest would be simple. Wrong! The next day I discovered the addresses where the SPEED and ROT bytes are stored. There was no progress because I still couldn't keep track of the program flow since too many subroutines were called from the keyword handling routines.

A similar problem arose with the zero page addresses. Often I suspected that a certain zero page location was used in connection with a specific function only, but I could not check this since it is absolutely impossible to find all the references to a certain address in a listing of 96 pages.

A colleague who had written an x-ref assembler on a Nova 820 computer made a cross reference table of Applesoft for me which solved most of my problems. An x-ref assembler lists all references that are made to an address. By using these references it is possible to trace the program flow in reverse order, making it easy to find the driver (main program) in the program you want to analyze. Furthermore, the references show where in the program a certain zero page (or other) location is used. (This helps to find out the meaning of the values stored in such a location.)

Apart from the references themselves, useful information provided by a cross reference table includes the number of references at a certain address. For instance, if you find a subroutine with more than five references, it is bound to be an important one and it certainly will be worth the trouble to find out what it does. As an example, the cross reference table of a small program is listed in figure 1.

When executing this program it will ask for a BASE. After typing in a number between one and nine, the program will display a counter on the screen which starts counting at zero in a notation with base equal to $\text{BASE} + 1$. The ASCII values

listed behind the mnemonics show that the last part of the program contains the text 'BASE (1-9) ?' Since the 'B' from BASE is referred to by address \$200D, this will be an address within a routine that displays text.

Another important point is the empty line at \$2024. Because this line is referred to by the instruction BNE \$2024 at \$202D, there must be a hidden instruction at \$2024. Hidden instructions are sometimes used (among others in Applesoft) to save a few bytes.

Note that the x-ref assembler lists addresses \$A0, \$AD, \$D3 and \$A0A9 as addresses used by the program. However, these addresses appear in the text "BASE (1-9) ?" since the disassembler has translated some text to valid opcodes. The x-ref assembler is thus not able to distinguish opcodes that are more or less randomly generated within text or tables from real opcodes. This means that some of the references listed by the x-ref assembler may not be valid.

Figure 1

0005-				2025
00A0-				203B
00AD-				203E
00D3-				2039
00FE-				2023
040D-				2020
05D5-				2007
05D6-				202A 2031
2000-2058FC	JSR	\$FC58	X	
2003-A222	LDX	#\$22	" "	
2005-A9B0	LDA	#\$B0)0	
2007-9DD505	STA	\$05D5,X	U	200B
200A-CA	DEX		J	
200B-DOFA	BNE	\$2007	Pz	
200D-BD3820	LDA	\$203E,X	=8	2016
2010-20EDFD	JSR	\$FDED	m}	
2013-E8	INX		h	
2014-E00C	CPX	#\$0C	`	
2016-DOF5	BNE	\$200D	Pu	
2018-AC00C0	LDY	\$C000	, @	201B
201B-10FB	BPL	\$2018	{	
201D-8C10C0	STY	\$C010	@	
2020-8C0D04	STY	\$040D		
2023-A5FE	LDA	\$FE	%~	
2024-				202D
2025-D605	DEC	\$05,X	V	
2027-A221	LDX	#\$21	"!	
2029-98	TYA			2035
202A-DDD605	CMP	\$05D6,X]V	
202D-DOF5	BNE	\$2024	Pu	
202F-A9B0	LDA	#\$B0)0	
2031-9DD605	STA	\$05D6,X	V	
2034-CA	DEX		J	
2035-10F2	BPL	\$2029	, r	
2037-60	RTS		,	
2038-C2	???		B	200D
2039-C1D3	CMP	(\$D3,X)	AS	
203B-C5A0	CMP	\$A0	E	
203D-AB	TAY		(
203E-B1AD	LDA	(\$AD),Y	1-	
2040-B9A9A0	LDA	\$A0A9,Y	9)	
2043-BF	???		?	
A0A9-				2040
C000-				2018
C010-				201D
FC58-				2000
FDED-				2010

The X-REF Assembler Program

Since I consider an x-ref assembler an indispensable software tool for my Apple, I wrote one. The text file of the program is listed in figure 2.

To run the x-ref assembler, BRUN CROSS ASSEMBLER and give the (monitor) command 800G to initialize the control Y vector. Next, load the binary program that has to be x-refed, starting at a user-defined location. In the sequel it will be assumed that this is location \$1000. In case you load from tape, the monitor MOVE command can be used to "move" the program to this location. After having performed these steps, the x-ref assembler can be executed by the command,

```
XXXX < YYYYY.ZZZZ control Y
```

where

XXXX is the origin of the program that has to be x-refed.

YYYY is the start address (i.e. \$1000) of the program in memory

ZZZZ is the end address of the program in memory.

For instance, if you want to make a cross reference table of ROM Applesoft, it first has to be moved to location \$1000 by the command 1000 < D000 .F800M. The x-ref assembler then can be executed by the command D000 < 1000.3800 control Y. After having typed in this command (followed by a carriage return) the display should show five figures after a few moments. These are:

Pass The number of passes (including print passes) made thus far.

SAR The start of the address range that is x-refed during the current pass.

EAR The end of the address range that is x-refed during the current pass.

TSP A table pointer.

PCU The user's program counter.

To explain these figures, it is necessary to give a brief description of the way the x-ref assembler works. The program starts (after the control Y command) by initializing a table which begins just behind the program that has to be x-refed and ends at a user-defined location. This table is used to store the references and consists of the format shown in table 1.

Table 1

Memory Location	Address	(Next Address)	(Previous Address)	References
ZZZZ + 1	0000	ZZZZ + 1 + 1*OFF1	FFFF	
ZZZZ + 1 + 1*OFF1	FFFF	FFFF	ZZZZ + 1	

The table is initialized with the values shown and each entry has a (user-defined) length of OFF1 bytes. Next, the x-ref assembler starts x-reffing the program, thereby keeping up two program counters. The first program counter (PC) points to the subsequent addresses of the instructions that have to be disassembled in the program starting at \$1000, while the second program counter (PCU) points to the corresponding addresses in the original program. The PC and PCU therefore differ by a constant with the value \$XXXX-\$1000.

Suppose now that the first instruction that is being disassembled is LDA \$00. The x-ref assembler then searches the table to see whether address \$00 is present already. Since this is the case, it stores the current value of PCU, say \$3000, as a reference at the entry of address \$00. If the second instruction is LDX \$03, the table is searched again, but this time no entry for address \$03 is found. Therefore this entry is added to the table and the pointers to the next and previous addresses are updated. After adding address \$03, the table appears as in table 2.

Table 2

Memory Location	Address	(Next Address)	(Previous Address)	References
$ZZZZ + 1$	0000	$ZZZZ + 1 + 2 * OFF1$	FFFF	3000
$ZZZZ + 1 + 1 * OFF1$	FFFF	FFFF	$ZZZZ + 1 + 2 * OFF1$	
$ZZZZ + 1 + 2 * OFF1$	0003	$ZZZZ + 1 + 1 * OFF1$	$ZZZZ + 1$	3002

When x-reffing a large program, the table eventually becomes full. If the x-ref assembler detects this, it narrows its search range by neglecting (in the current pass) all addresses larger than the largest address found so far. The largest address of the search range is displayed on the screen under the heading EAR. Thus, as soon as the table is full, this address will change to a smaller value.

Suppose now that the table is full and the x-ref assembler finds an address, say QQQQ, that is in the search range but not in the table. In that case, an entry for this address has to be merged into the table. The program does this by first changing the value of the largest address in the search range (EAR) to the next largest address in the search range. Note that this address can be found by using the "previous address" pointer that is stored at each entry. The address QQQQ is then stored in the entry of the previous largest address which is empty now. Finally, the 'next address' pointer of the largest address smaller than QQQQ, the 'next address' and 'previous address' pointer of QQQQ, and the 'previous address' pointer of the smallest address larger than QQQQ, are updated to link QQQQ to the chain of addresses.

If the x-ref pass has been completed, the results are displayed or printed up to the largest address in the search range. In case all addresses could not be stored in the previous x-ref pass, the program puts the smallest address of the (new) search range (SAR) equal to the largest address of the (previous) search range plus one (i.e., $SAR = EAR + 1$) whereas EAR is put equal to FFFF. Next, another x-ref pass is made and this process continues until the references to all addresses have been displayed or printed.

Finally, I'll discuss some of the program parameters that can be changed by the user. These parameters can be found in the DATA SECTION of the listing.

The first four parameters are used to inform the program about your printer configuration. If you don't have a printer, put PRFLG equal to \$00 and neglect the three parameters: PNTL, PNTH and CSND. If PRFLG equals zero, all output will be directed to the video screen. Since the output may run a little bit too fast on the screen to make notes, you can display one address (plus references) at a time by repeatedly pressing the escape key. Any other key will continue the output at normal speed.

I have distinguished three ways that printers can be connected to the Apple:

1. You may have an interface card, say in slot 2. In that case, put PNTL equal to the slot number (i.e. 2) and put PNTH as well as CSND equal to zero.
2. If you use a subroutine that drives the printer, put the low byte of this subroutine in PNTL and the high byte in PNTH, and put CSND equal to zero.
3. If the printer routine already has been connected before execution of the x-ref assembler, a special character to activate or deactivate the printer can be sent by storing the "printer off" character in PNTL, the "printer on" character in PNTH and by putting CSND equal to \$FF.

Editor's note: For serial interface card in slot zero BRUN CROSS-SLOT-ZERO in place of CROSS ASSEMBLER to send output to the printer.

The next parameter is EOT1. This parameter contains the highest memory address used by the x-ref assembler (HIMEM). In the listing, EOT1 is put equal to \$8FFF since my printer routine starts at \$9000, but if you don't use a printer or disk, EOT1 can be put equal to the highest RAM address. The parameter OFF1 equals the length of a table entry. Because 6 bytes per entry are needed to store the address and the pointers, OFF1 equals \$34 which means that $(52-6)/2 = 23$ references can be stored per entry. The last parameter, AMAX, is the maximal number of addresses that will be printed per line, if a printer has been connected.

I hope these parameters will offer you sufficient selection possibilities to make the type of cross reference table you need. If they do not, just x-ref the x-ref assembler, analyze it and make a version suited to your needs.

Figure 2

```

0800      1 ;*****
0800      2 ;*
0800      3 ;*   CROSS ASSEMBLER *
0800      4 ;*           BY *
0800      5 ;*   CORNELIS BONGERS *
0800      6 ;*
0800      7 ;*           CROSS *
0800      8 ;*
0800      9 ;*   COPYRIGHT (C) 1982 *
0800     10 ;*   MICRO INK, INC. *
0800     11 ;* CHELMSFORD, MA 01824 *
0800     12 ;* ALL RIGHTS RESERVED *
0800     13 ;*
0800     14 ;*****
0800     15 ;
0800     16 ;
0800     17 ;
0800     18           ORG $800
009B     19 ESC           EPZ $9B           ;ESCAPE
008C     20 FF           EPZ $8C           ;FORM FEED
C000     21 KBD           EQU $C000
C010     22 CLKBD        EQU $C010
002D     23 RM           EPZ $2D           ;MONITOR LOCATIONS
002C     24 LM           EPZ $2C
0036     25 CSWL        EPZ $36
003C     26 A1L         EPZ $3C
003E     27 A2L         EPZ $3E
0042     28 A4L         EPZ $42
003A     29 PC           EPZ $3A
0024     30 CH           EPZ $24
002F     31 LEN         EPZ $2F
002E     32 FORM        EPZ $2E
F9C0     33 MNML        EQU $F9C0
FA00     34 MNMR        EQU $FA00
0800     35 ;
0800     36 ;
F88C     37 FMIN          EQU $F88C           ;MONITOR SUBROUTINES
FC58     38 CLSC          EQU $FC58
FD96     39 PRYX2        EQU $FD96
FDDA     40 PRBYT         EQU $FDDA
F94A     41 PRBL2         EQU $F94A
F948     42 PRBAK         EQU $F948
F9B4     43 CHAR1         EQU $F9B4
F9BA     44 CHAR2         EQU $F9BA
FDED     45 COUT           EQU $FDED
FD8E     46 CROUT          EQU $FD8E
FE95     47 OUTP          EQU $FE95
F953     48 PCADJ         EQU $F953
0800     49 ;
0800     50 ;
007E     51 AST           EPZ $7E           ;DATA REGISTERS
0080     52 PC1           EPZ $80
0082     53 PC2           EPZ $82
0084     54 PCU1         EPZ $84
0086     55 PCU2         EPZ $86
0000     56 PASS          EPZ $00
0001     57 SAR           EPZ $01           ;START ADDRESS RANGE
0003     58 EAR           EPZ $03           ;END ADDRESS RANGE
0005     59 TSP          EPZ $05           ;TABLE POINTER
0007     60 PCU          EPZ $07           ;USERS PROGRAM POINTER
0088     61 SOT          EPZ $88           ;START OF TABLE
008A     62 EOT          EPZ $8A           ;END OF TABLE
008C     63 RUNT         EPZ $8C           ;GENERAL USE
008E     64 END          EPZ $8E           ;POINTER TO LARGEST ADDRESS
0090     65 HULP         EPZ $90           ;TEMPORARY STORAGE
0092     66 SAVX         EPZ $92           ;STORAGE X REGISTER
0093     67 CNTR         EPZ $93           ;BYTE COUNTER
0094     68 OFF          EPZ $94           ;LENGTH OF TABLE ENTRY
0095     69 EOP          EPZ $95           ;END OF PROGRAM FLAG
0096     70 TFUL         EPZ $96           ;TABLE FULL FLAG
0097     71 ACNT         EPZ $97           ;COUNTER
0098     72 ETBL         EPZ $98           ;END OF TABLE FLAG
0800     73 ;

```

```

0800          74 ;
0800          75 ;*** START OF PROGRAM ***
0800          76 ;
0800          77 ; * INITIALIZATION *
0800          78 ;
0800 A9 4C    79          LDA #$4C
0802 8D F8 03 80          STA $3F8
0805 A9 2E    81          LDA #BEGIN          ;BRUN THIS PART
0807 8D F9 03 82          STA $3F9          ;INIT CONTROL Y VECTOR
080A A9 08    83          LDA /BEGIN
080C 8D FA 03 84          STA $3FA
080F 60       85          RTS
0810          86 ;
0810          87 ; * DATA SECTION *
0810          88 ;
0810 FF       89 PRLFG   BYT $FF          ;SET PRINTER FLAG
0811 8E       90 PNTL    BYT $8E          ;^N TO DEACTIVATE PRINTER

0812 90       91 PNTH    BYT $90          ;^P TO ACTIVATE PRINTER
0813 FF       92 CSND    BYT $FF          ;SET CHAR SEND BYTE
0814 FF 8F    93 EOT1    ADR $8FFF        ;END OF MEMORY USED (HIMEM)
0816 34       94 OFF1    BYT $34          ;LENGT1 OF A TABLE ENTRY
0817 0A       95 AMAX    BYT $0A          ;MAXIMUM NO. OF
                                         ADDRESSES/LINE

0818          96 ;
0818 50 41 53 97 HEAD    ASC 'PASSAR EAR TSP PCU'
081B 53 53 41
081E 52 20 45
0821 41 52 20
0824 54 53 50
0827 20 50 43
082A 55
082B 8D       98          BYT $8D
082C 00 00    99 SAR1    ADR $0000          ;START ADDRESS RANGE
082E          100 ;
082E          101 ; * INIT PROGRAM PARAMETERS *
082E          102 ;
082E A2 FE    103 BEGIN    LDX #$FE
0830 38       104          SEC
0831 B5 40    105 IFR      LDA A2L+$02,X
0833 69 00    106          ADC #$00          ;INIT START OF TABLE
0835 95 8A    107          STA SOT+$02,X        ;TO SOT=A2L+1
0837 B5 3E    108          LDA A1L+$02,X
0839 95 82    109          STA PC1+$02,X        ;INIT PROGRAM COUNTERS
083B 95 84    110          STA PC2+$02,X
083D B5 44    111          LDA A4L+$02,X
083F 95 86    112          STA PCU1+$02,X        ;INIT USERS PROGRAM COUNTER
0841 95 88    113          STA PCU2+$02,X
0843 BD 2E 07 114          LDA SAR1-$FE,X        ;INIT START ADDRESS RANGE
0846 95 03    115          STA SAR+$02,X
0848 E8       116          INX
0849 D0 E6    117          BNE IFR
084B 86 95    118          STX EOP          ;INIT END OF PROGRAM FLAG
084D 86 98    119          STX ETBL        ;AND END OF TABLE FLAG
084F AD 16 08 120          LDA OFF1        ;INIT LENGTH TABLE ENTRY
0852 85 94    121          STA OFF
0854 AD 14 08 122          LDA EOT1
0857 E5 94    123          SBC OFF          ;END INIT END OF TABLE
0859 85 8A    124          STA EOT        ;TO END OF MEMORY-1-OFF
085B AD 15 08 125          LDA EOT1+1
085E E9 00    126          SBC #$00
0860 85 8B    127          STA EOT+1
0862 A9 80    128          LDA #$80
0864 85 00    129          STA PASS          ;INIT PASS
0866 20 58 FC 130          JSR CLSC        ;CLEAR SCREEN
0869          131 ;
0869          132 ; * MAIN PROGRAM *
0869          133 ;
0869 A2 00    134 AIT      LDX #$00          ;CLEAR TABLE FULL POINTER
086B 86 96    135          STX TFUL
086D E8       136          INX
086E 20 09 0C 137          JSR SPCN          ;INIT PROGRAM COUNTERS
0871 A9 FF    138          LDA #$FF        ;INIT END ADDRESS RANGE
0873 85 03    139          STA EAR
0875 85 04    140          STA EAR+1
0877 20 8E 08 141          JSR POUT          ;DEACTIVATE PRINTER

```

```

087A 20 A1 08 142 JSR XASM ;CROSS ASSEMBLE
087D A2 01 143 LDX #$01
087F 20 29 0C 144 JSR PONOF ;ACTIVATE PRINTER
0882 20 26 0B 145 JSR PRINT ;PRINT RESULTS
0885 A5 96 146 LDA TFUL ;WAS TABLE FULL?
0887 D0 0A 147 BNE NRDY ;YES, BRANCH
0889 A9 8C 148 LDA #FF ;READY, GIVE FORM FEED
088B 20 ED FD 149 JSR COUT
088E A2 00 150 POUT LDX #$00 ;DEACTIVATE PRINTER
0890 4C 29 0C 151 JMP PONOF ;RTS TO MONITOR
0893 38 152 NRDY SEC
0894 A2 FE 153 LDX #$FE
0896 B5 05 154 NLA LDA EAR+$02,X
0898 69 00 155 ADC #$00 ;PUT SAR=EAR+1
089A 95 03 156 STA SAR+$02,X
089C E8 157 INX
089D D0 F7 158 BNE NLA
089F FO C8 159 BEQ AIT ;ALWAYS
08A1 160 ;
08A1 161 ; * CROSS ASSEMBLE SUBROUTINE *
08A1 162 ;
08A1 20 5D 09 163 XASM JSR IRUNT ;INIT RUNT
08A4 A9 FF 164 LDA #$FF
08A6 A2 00 165 LDX #$00
08A8 86 8C 166 STX RUNT
08AA A6 8B 167 LDX EOT+1
08AC C8 168 MFUR INY
08AD D0 02 169 BNE STOR
08AF E6 8D 170 INC RUNT+1
08B1 91 8C 171 STOR STA (RUNT),Y ;FILL TABLE WITH FF'S
08B3 E4 8D 172 CPX RUNT+1
08B5 D0 F5 173 BNE MFUR
08B7 C4 8A 174 CPY EOT
08B9 D0 F1 175 BNE MFUR
08BB A0 00 176 LDY #$00
08BD 98 177 TYA
08BE 91 88 178 STA (SOT),Y ;INIT FIRST TABLE ENTRY
08C0 C8 179 INY
08C1 91 88 180 STA (SOT),Y
08C3 18 181 CLC
08C4 A2 FE 182 LDX #$FE
08C6 A5 94 183 LDA OFF
08C8 75 8A 184 NLP ADC SOT+$02,X
08CA 95 07 185 STA TSP+$02,X ;TSP=SOT+OFF
08CC 95 90 186 STA END+$02,X ;END=TSP
08CE C8 187 INY
08CF 91 88 188 STA (SOT),Y ;NEXT ENTRY IS TSP
08D1 A9 00 189 LDA #$00
08D3 E8 190 INX
08D4 D0 F2 191 BNE NLP
08D6 C8 192 INY
08D7 A5 88 193 LDA SOT ;INIT SECOND TABLE ENTRY
08D9 91 05 194 STA (TSP),Y ;PREVIOUS ENTRY IS SOT
08DB A5 89 195 LDA SOT+1
08DD C8 196 INY
08DE 91 05 197 STA (TSP),Y
08E0 20 67 09 198 JSR ATSP1 ;SET TSP TO FIRST EMPTY ENTRY
08E3 20 8E FD 199 JSR CROUT ;CARRIAGE RETURN
08E6 A0 00 200 LDY #$00 ;PRINT HEADING
08E8 A2 04 201 CP1 LDX #$04
08EA B9 18 08 202 CPR LDA HEAD,Y
08ED 20 ED FD 203 JSR COUT
08FO C8 204 INY
08F1 CA 205 DEX
08F2 D0 F6 206 BNE CPR
08F4 20 48 F9 207 JSR PRBAK
08F7 C0 14 208 CPY #$14
08F9 D0 ED 209 BNE CP1
08FB 20 6F 0A 210 JSR APASS ;ADJUST PASS
08FE A5 00 211 DNI LDA PASS
0900 29 7F 212 AND #$7F
0902 A0 01 213 LDY #$01
0904 84 24 214 STY CH ;INIT CURSOR
0906 88 215 DEY
0907 FO 09 216 BEQ PRT ;ALWAYS

```

```

0909 B9 00 00 217 ANP LDA PASS,Y ;DISPLAY PASS,SAR,EAR,
090C 20 DA FD 218 JSR PRBYT ;TSP AND PCU
090F B9 FF FF 219 LDA PASS-1,Y
0912 20 DA FD 220 PRT JSR PRBYT
0915 20 48 F9 221 JSR PRBAK
0918 C8 222 INY
0919 C8 223 INY
091A C0 0A 224 CPY #$$
091C D0 EB 225 BNE ANP
091E A9 FF 226 LDA #$$F
0920 85 93 227 STA CNTR ;INIT COUNTER
0922 20 8F 09 228 JSR DISA ;DISASSEMBLE ONE INSTRUCTION
0925 A6 93 229 LDX CNTR
0927 30 2E 230 BMI ENF ;BRANCH IF NO ADDRESS
0929 D0 06 231 BNE NZP ;BRANCH IF NO ZERO PAGE ADDRESS

092B A5 7E 232 LDA AST ;ADJUST AST FOR ZP INSTRUCTIONS

092D 85 7F 233 STA AST+1
092F 86 7E 234 STX AST
0931 20 78 0A 235 NZP JSR RANGE ;CHECK WHETHER ADDRESS IS IN
0934 90 21 236 BCC ENF ;TABLE RANGE AND BRANCH IF NOT

0936 20 8C 0A 237 JSR SEAR ;SEARCH ADDRESS IN TABLE
0939 B0 03 238 BCS FOUN ;BRANCH IF EXACT MATCH
093B 20 B2 0A 239 JSR MERGE ;MERGE IF NOT
093E A0 05 240 FOUN LDY #05
0940 C8 241 NEF INY ;SEARCH ROOM IN TABLE ENTRY
0941 C4 94 242 CPY OFF ;TO STORE USERS PROGRAM COUNTER

0943 F0 12 243 BEQ ENF ;BRANCH IF ENTRY FULL
0945 B1 8C 244 LDA (RUNT),Y
0947 C8 245 INY
0948 31 8C 246 AND (RUNT),Y
094A 49 FF 247 EOR #$$F
094C D0 F2 248 BNE NEF
094E A5 07 249 LDA PCU ;ROOM FOUND, STORE
0950 91 8C 250 STA (RUNT),Y ;USERS PROGRAM COUNTER
0952 88 251 DEY
0953 A5 08 252 LDA PCU+1
0955 91 8C 253 STA (RUNT),Y
0957 20 72 09 254 ENF JSR ENFL ;ADJUST PROGRAM COUNTERS
095A 90 A2 255 BCC DNI
095C 60 256 RTS ;RTS IF END OF PROGRAM REACIED

095D 257 ;
095D 258 ; * IRUNT/ATSP2 : PUT RUNT=SOT OR TSP=TSP+OFF
095D 259 ;
095D A4 89 260 IRUNT LDY SOT+1
095F 84 8D 261 STY RUNT+1
0961 A4 88 262 LDY SOT
0963 84 8C 263 STY RUNT
0965 60 264 RTS
0966 18 265 ATSP2 CLC
0967 A5 05 266 ATSP1 LDA TSP
0969 65 94 267 ADC OFF
096B 85 05 268 STA TSP
096D 90 02 269 BCC RETR
096F E6 06 270 INC TSP+1
0971 60 271 RETR RTS
0972 272 ;
0972 273 ; * ENFL:SUBROUTINE ADJUST PROGRAM COUNTERS
0972 274 ; * AND CHECK ON END OF PROGRAM
0972 275 ;
0972 20 60 0A 276 ENFL JSR PCAD ;ADJUST USERS PROGRAM COUNTER
0975 85 07 277 STA PCU
0977 84 08 278 STY PCU+1
0979 20 53 F9 279 JSR PCADJ ;ADJUST PROGRAM COUNTER
097C 85 3A 280 STA PC
097E 84 3B 281 STY PC+1

```

58 Machine-Language Aids

```

0980 38          282          SEC
0981 E5 88      283          SBC SOT          ;END OF PROGRAM REACHED?
0983 98          284          TYA
0984 E5 89      285          SBC SOT+1
0986 24 00      286          BIT PASS
0988 10 04      287          BPL KLR          ;YES, RETURN WITH CARRY SET
098A 90 02      288          BCC KLR          ;IF X-ASSEMBLE PASS
098C E6 95      289          INC EOP          ;IF PRINT PASS, SET EOP FLAG
098E 60          290          KLR      RTS
098F            291          ;
098F            292          ; * DISA:DISASSEMBLE ONE INSTRUCTION (X-ASSEMBLE PASS
098F            293          ; * IF PASS POSITIVE, PRINT PASS IF PASS NEGATIVE)
098F            294          ; * SEE ALSO APPLE MONITOR FOR COMMENTS
098F            295          ;
098F A2 00      296          DISA      LDX #$00
0991 20 8C F8   297          JSR FMIN          ;DETERMINE FORMAT INSTRUCTION
0994 24 00      298          BIT PASS          ;IF PASS IS POS,
0996 10 4A      299          BPL XASS          ;CROSS ASSEMBLE
0998 48          300          PHA
0999 A6 07      301          LDX PCU
099B A4 08      302          LDY PCU+1
099D 20 96 FD   303          JSR PRYX2          ;PRINT USERS PROGRAM COUNTER
09A0 A0 00      304          LDY #$00
09A2 B1 3A      305          PROP      LDA (PC),Y
09A4 20 DA FD   306          JSR PRBYT          ;PRINT OPCODES
09A7 4C AD 09   307          JMP NOBL          ;IN A 8 CHAR. FIELD
09AA 20 4A F9   308          PRBK      JSR PRBL2
09AD C4 2F      309          NOBL      CPY LEN
09AF CB          310          INY
09B0 90 F0      311          BCC PROP
09B2 A2 02      312          LDX #$02
09B4 C0 03      313          CPY #$03
09B6 90 F2      314          BCC PRBK
09B8 CA          315          DEX
09B9 20 4A F9   316          JSR PRBL2          ;PRINT BLANK
09BC A2 03      317          LDX #$03
09BE 68          318          PLA
09BF A8          319          TAY
09C0 B9 C0 F9   320          LDA MNML,Y          ;FETCH MNEMONIC
09C3 85 2C      321          STA LM
09C5 B9 00 FA   322          LDA MNMR,Y
09C8 85 2D      323          STA RM
09CA A9 00      324          M1      LDA #$00
09CC A0 05      325          LDY #$05
09CE 06 2D      326          M2      ASL RM
09D0 26 2C      327          ROL LM
09D2 2A          328          ROL
09D3 88          329          DEY
09D4 D0 F8      330          BNE M2
09D6 69 BF      331          ADC #$BF
09D8 20 ED FD   332          JSR COUT
09DB CA          333          DEX
09DC D0 EC      334          BNE. M1
09DE E8          335          INX
09DF 20 4A F9   336          JSR PRBL2          ;PRINT BLANK AFTER MNEMONIC
09E2 A4 2F      337          XASS      LDY LEN
09E4 A2 06      338          LDX #$06
09E6 E0 03      339          PRAD1     CPX #$03
09E8 F0 27      340          BEQ PRAD5          ;FETCH ADDRESS IF PRESENT
09EA 06 2E      341          PRAD2     ASL FORM
09EC 90 18      342          BCC PRAD3
09EE BD B3 F9   343          LDA CHAR1-1,X
09F1 24 00      344          BIT PASS
09F3 30 06      345          BMI OUT
09F5 C9 A3      346          CMP #$A3          ;IS CHAR "#" ?
09F7 F0 66      347          BEQ RTS3          ;YES, STOP DISASSEMBLING
09F9 D0 0B      348          BNE PRAD3          ;NO, CONTINUE
09FB 20 ED FD   349          OUT      JSR COUT
09FE BD B9 F9   350          LDA CHAR2-1,X
0A01 F0 03      351          BEQ PRAD3
0A03 20 ED FD   352          JSR COUT
0A06 CA          353          PRAD3     DEX
0A07 D0 DD      354          BNE PRAD1
0A09 F0 1E      355          BEQ EMNO          ;ALWAYS
0A0B 88          356          PRAD4     DEY

```

```

OAOC 30 DC          357          BMI PRAD2
OA0E 20 4E OA      358          JSR MPBY          ;PRINT ADDRESS BYTE
OA11 A5 2E          359 PRAD5   LDA FORM
OA13 C9 E8          360          CMP #$E8
OA15 B1 3A          361          LDA (PC),Y
OA17 90 F2          362          BCC PRAD4
OA19 20 63 OA      363          JSR PCA3
OA1C AA             364          TAX
OA1D E8             365          INX
OA1E D0 01          366          BNE PRYX
OA20 C8             367          INY
OA21 98             368 PRYX   TYA
OA22 20 4E OA      369          JSR MPBY
OA25 8A             370          TXA
OA26 20 4E OA      371          JSR MPBY
OA29 24 00          372 EMNO   BIT PASS
OA2B 10 32          373          BPL RTS3          ;IF NO PRINT PASS, RTS
OA2D A9 18          374          LDA #$18
OA2F 85 24          375          STA CH          ;TAB FOR PRINTER OR VIDEO
OA31 A0 00          376          LDY #$00
OA33 B1 3A          377 OOP   LDA (PC),Y
OA35 09 80          378          ORA #$80
OA37 C9 FF          379          CMP #$FF          ;MY PRINTER DOESN'T ACCEPT FF
OA39 FO 04          380          BEQ SPTA
OA3B C9 A0          381          CMP #$A0          ;OUTPUT ASCII VALUES OPCODES
OA3D B0 02          382          BCS CHT
OA3F A9 A0          383 SPTA   LDA #$A0
OA41 20 ED FD      384 CHT   JSR COUT
OA44 C4 2F          385          CPY LEN
OA46 C8             386          INY
OA47 90 EA          387          BCC OOP
OA49 A9 1E          388          LDA #$1E          ;SET TAB FOR PRINTER OR VIDEO
OA4B 4C D1 OB      389          JMP ITAB1
OA4E                390          ;
OA4E                391          ; * MPBY:PRINT BYTE IF PRINT PASS
OA4E                392          ; * STEAL (ADDRESS) BYTE IF X-PASS
OA4E                393          ;
OA4E 24 00          394 MPBY   BIT PASS
OA50 10 03          395          BPL NPR
OA52 4C DA FD      396          JMP PRBYT          ;PRINT BYTE AND RTS
OA55 E6 93          397 NPR   INC CNTR          ;COUNT ADDRESS BYTES
OA57 86 92          398          STX SAVX          ;SAVE X-REGISTER
OA59 A6 93          399          LDX CNTR
OA5B 95 7E          400          STA AST,X          ;SAVE ADDRESS BYTE
OA5D A6 92          401          LDX SAVX
OA5F 60             402 RTS3   RTS
OA60                403          ;
OA60                404          ; * PCAD:ADJUST USERS PROGRAM COUNTER
OA60                405          ; * OR CALCULATE TARGET FOR RELATIVE BRANCH
OA60                406          ;
OA60 38             407 PCAD   SEC
OA61 A5 2F          408          LDA LEN
OA63 A4 08          409 PCA3   LDY PCU+1
OA65 AA             410          TAX
OA66 10 01          411          BPL PCA4
OA68 88             412          DEY
OA69 65 07          413 PCA4   ADC PCU
OA6B 90 01          414          BCC RTS4
OA6D C8             415          INY
OA6E 60             416 RTS4   RTS
OA6F                417          ;
OA6F                418          ; * APASS:ADJUST PASS
OA6F                419          ;
OA6F A4 00          420 APASS  LDY PASS
OA71 C8             421          INY
OA72 98             422          TYA
OA73 49 80          423          EOR #$80
OA75 85 00          424          STA PASS
OA77 60             425          RTS
OA78                426          ;
OA78                427          ; * RANGE:CHECK WIETHER ADDRESS IS IN SEARCH RANGE
OA78                428          ; * RETURN WITH CARRY CLEAR IF NOT, ELSE WITH CARRY SET
OA78                429          ;
OA78 38             430 RANGE  SEC

```

60 Machine-Language Aids

0A79	A5 03	431		LDA EAR	
0A7B	E5 7F	432		SBC AST+1	
0A7D	A5 04	433		LDA EAR+1	
0A7F	E5 7E	434		SBC AST	
0A81	90 08	435		BCC NIR	
0A83	A5 7F	436		LDA AST+1	
0A85	E5 01	437		SBC SAR	
0A87	A5 7E	438		LDA AST	
0A89	E5 02	439		SBC SAR+1	
0A8B	60	440	NIR	RTS	
0A8C		441			
0A8C		442		; * SEAR:SEARCH ADDRESS IN TABLE, RETURN WITH CARRY SET	
0A8C		443		; * IF FOUND, ELSE WITH CARRY CLEAR	
0A8C		444			
0A8C	20 5D 09	445	SEAR	JSR IRUNT	;PUT RUNT=SOT
0A8F	38	446		SEC	
0A90	A0 01	447	CON	LDY #\$01	
0A92	A5 7F	448		LDA AST+1	
0A94	F1 8C	449		SBC (RUNT),Y	
0A96	AA	450		TAX	
0A97	88	451		DEY	
0A98	A5 7E	452		LDA AST	
0A9A	F1 8C	453		SBC (RUNT),Y	
0A9C	90 05	454		BCC RTS5	;RTS IF TABLE ENTRY ADDRESS IS LARGER THAN ADDRESS SEARCHED FOR
0A9E	D0 04	455		BNE NFND	
0AA0	8A	456		TXA	
0AA1	D0 01	457		BNE NFND	
0AA3	60	458	RTS5	RTS	
0AA4	A0 02	459	NFND	LDY #\$02	
0AA6	B1 8C	460		LDA (RUNT),Y	;GET NEXT TABLE ENTRY IN RUNT
0AA8	AA	461		TAX	
0AA9	C8	462		INY	
0AAA	B1 8C	463		LDA (RUNT),Y	
0AAC	85 8D	464		STA RUNT+1	
0AAE	86 8C	465		STX RUNT	
0AB0	B0 DE	466		BCS CON	;ALWAYS
0AB2		467			
0AB2		468		; * MERGE:MERGE OR ADD ADDRESS (IN) TO TABLE IF	
0AB2		469		; * NO EXACT MATCH FOUND	
0AB2		470			
0AB2	A5 96	471	MERGE	LDA TFUL	;IS TABLE FULL?
0AB4	F0 1C	472		BEQ NFUL	;BRANCH IF NOT
0AB6	A5 8E	473		LDA END	;ELSE RESERVE ENTRY LARGEST
0AB8	85 05	474		STA TSP	;ADDRESS FOR CURRENT ADDRESS
0ABA	A5 8F	475		LDA END+1	
0ABC	85 06	476		STA TSP+1	
0ABE	A0 04	477		LDY #\$04	;STORE NEXT BUT LARGEST ADDRESS
0AC0	20 1C 0C	478		JSR CFF1	;ENTRY IN END FOR LATER USE
0AC3	85 8F	479		STA END+1	
0AC5	86 8E	480		STX END	
0AC7	A4 94	481		LDY OFF	
0AC9	A9 FF	482		LDA #\$FF	
0ACB	88	483	PR	DEY	;STORE FF'S IN TABLE ENTRY
0ACC	91 05	484		STA (TSP),Y	
0ACE	C0 06	485		CPY #\$06	
0ADO	D0 F9	486		BNE PR	
0AD2	A0 05	487	NFUL	LDY #\$05	
0AD4	A2 01	488		LDX #\$01	
0AD6	B1 8C	489	RET	LDA (RUNT),Y	;ADJUST POINTERS
0ADB	91 05	490		STA (TSP),Y	; (TSP),4,5=(RUNT),4,5
0ADA	95 90	491		STA HULP,X	;HULP,0,1=(RUNT),4,5
0ADC	B5 05	492		LDA TSP,X	
0ADE	91 8C	493		STA (RUNT),Y	; (RUNT),4,5=TSP,0,1
0AE0	88	494		DEY	
0AE1	CA	495		DEX	
0AE2	10 F2	496		BPL RET	
0AE4	A2 01	497		LDX #\$01	
0AE6	B1 90	498	REK	LDA (HULP),Y	
0AE8	91 05	499		STA (TSP),Y	
0AEA	B5 05	500		LDA TSP,X	
0AEC	91 90	501		STA (HULP),Y	; (HULP),2,3=TSP,0,1
0AEE	95 8C	502		STA RUNT,X	;RUNT,0,1=TSP,0,1

```

OAF0 88      503      DEY
OAF1 CA      504      DEX
OAF2 10 F2   505      BPL REK
OAF4 A5 7F   506      LDA AST+1      ;(TSP),0,1=ADDRESS
OAF6 91 05   507      STA (TSP),Y
OAF8 A5 7E   508      LDA AST
OAF9 88      509      DEY
OAFB 91 05   510      STA (TSP),Y
OAFD A5 96   511      LDA TFUL      ;IS TABLE FULL?
OAFF D0 0E   512      BNE YFULL     ;YES, BRANCH
OB01 20 66 09 513      JSR ATSP2     ;NO, ADJUST TSP
OB04 38      514      SEC
OB05 E5 8A   515      SBC EOT      ;CHECK WHETHER TABLE
                                     IS FULL NOW
OB07 A5 06   516      LDA TSP+1
OB09 E5 8B   517      SBC EOT+1
OB0B 90 18   518      BCC RTSS     ;NO, BRANCH
OB0D E6 96   519      INC TFUL     ;YES, SET TABLE FULL POINTER
OB0F A0 04   520      YFULL LDY #$04
OB11 B1 8E   521      LDA (END),Y  ;SET END ADDRESS RANGE
OB13 85 90   522      STA HULP
OB15 C8      523      INY
OB16 B1 8E   524      LDA (END),Y
OB18 85 91   525      STA HULP+1
OB1A A0 01   526      LDY #$01
OB1C B1 90   527      LDA (HULP),Y
OB1E 85 03   528      STA EAR
OB20 88      529      DEY
OB21 B1 90   530      LDA (HULP),Y
OB23 85 04   531      STA EAR+1
OB25 60      532      RTSS
OB26         533      RTS
OB26         534      ; * PRINT: PRINT PASS
OB26         535      ;
OB26 20 6F 0A 536      PRINT JSR APASS
OB29 A2 03   537      LDX #$03
OB2B 20 09 0C 538      JSR SPCN     ;RESTORE PRINT COUNTERS
OB2E B5 88   539      NEL LDA SOT,X
OB30 95 05   540      STA TSP,X   ;TSP=SOT
OB32 CA      541      DEX
OB33 10 F9   542      BPL NEL
OB35 20 1A 0C 543      JSR CFFF     ;(TSP),6,7=$FFFF ?
OB38 D0 03   544      BNE PZER    ;BRANCH IF NOT
OB3A 20 DF 0B 545      JSR CHKR     ;YES, NEGLECT FIRST ENTRY
OB3D AD 00 0C 546      PZER LDA KBD ;KEYBOARD INPUT = ESCAPE
                                     CHAR.?
OB40 C9 9B   547      CMP #ESC
OB42 D0 08   548      BNE PZERT   ;NO, BRANCH
OB44 8D 10 0C 549      STA CLKBD   ;CLEAR STROBE
OB47 AD 00 0C 550      ASK LDA KBD   ;WAIT FOR ANOTHER STROBE
OB4A 10 FB   551      BPL ASK
OB4C A5 95   552      PZERT LDA EOP  ;END OF PROGRAM FLAG ON?
OB4E D0 31   553      BNE PAI     ;YES, DO NOT DISASSEMBLE
OB50 A5 98   554      LDA ETBL   ;IF END OF TABLE THEN
OB52 D0 20   555      BNE PAD     ;DISASSEMBLE ONLY
OB54 A0 01   556      LDY #$01
OB56 38      557      SEC
OB57 B1 05   558      LDA (TSP),Y
OB59 E5 07   559      SBC PCU
OB5B AA      560      TAX
OB5C 88      561      DEY
OB5D B1 05   562      LDA (TSP),Y
OB5F E5 08   563      SBC PCU+1   ;ADDRESS EQUAL TO PCU?
OB61 90 1E   564      BCC PAI     ;NO, ADDRESS IS SMALLER
OB63 D0 0F   565      BNE PAD     ;NO, ADDRESS IS LARGER
OB65 8A      566      TXA
OB66 D0 0C   567      BNE PAD
OB68 20 8F 09 568      JSR DISA   ;ADDRESS=PCU HERE, PRINT
OB6B 20 95 0B 569      JSR INFO   ;ADDRESS, DISASS. AND
                                     TABLE INFO
OB6E 20 72 09 570      JSR ENFL   ;ADJUST PROGRAM COUNTERS
OB71 4C 90 0B 571      JMP CHEK
OB74 20 8F 09 572      PAD JSR DISA  ;PRINT ADDRESS AND
                                     DISASSEMBLE
OB77 20 72 09 573      JSR ENFL
OB7A A5 95   574      LDA EOP

```

62 Machine-Language Aids

```

OB7C 25 98      575      AND ETBL      ;RTS EOP=1 AND ETBL=1
OB7E FO BD      576      BEQ PZER
OB80 60          577      RTS
OB81 A0 01      578 PAI    LDY #S01      ;PRINT ADDRESS AND INFO
OB83 B1 05      579      LDA (TSP),Y
OB85 AA          580      TAX
OB86 88          581      DEY
OB87 B1 05      582      LDA (TSP),Y
OB89 A8          583      TAY
OB8A 20 96 FD   584      JSR PRYX2
OB8D 20 95 OB   585      JSR INFO
OB90 20 DF OB   586 CHEK    JSR CHKR
OB93 DO A8      587      BNE PZER      ;ALWAYS
OB95            588      ;
OB95            589      ; * INFO:PRINT TABLE ENTRY INFORMATION
OB95            590      ;
OB95 A0 06      591 INFO    LDY #S06
OB97 20 CF OB   592      JSR ITAB      ;SET TAB FOR PRINTER
OB9A 20 1C OC   593 NPRQ    JSR CFF1
OB9D FO 2F      594      BEQ RS        ;IF ADDRESS=$FFFF THEN READY
OB9F 48          595 PINT    PHA        ;SAVE ACCU
OBA0 8A          596      TXA
OBA1 48          597      PHA
OBA2 A5 97      598      LDA ACNT
OBA4 2D 10 08   599      AND PRFLG    ;MAXIMUM NO. OF ADDRESSES
OBA7 CD 17 08   600      CMP AMAX     ;PER LINE PRINTED?
OBAA 90 06      601      BCC NCRT    ;BRANCH IF NOT
OBAC 20 8E FD   602      JSR CROUT   ;CARRIAGE RETURN IF YES
OBAF 20 CF OB   603      JSR ITAB    ;SET TAB AND INIT ACNT
OBB2 98          604 NCRT    TYA
OBB3 E6 97      605      INC ACNT
OBB5 OD 10 08   606      ORA PRFLG
OBB8 C9 07      607      CMP #S07
OBBA FO 05      608      BEQ NBLK
OBBC A2 01      609      LDX #S01    ;PRINT BLANK
OBBE 20 4A F9   610      JSR PRBL2
OBC1 68          611 NBLK    PLA        ;FOLLOWED BY THE ADDRESS
OBC2 20 DA FD   612      JSR PRBYT
OBC5 68          613      PLA
OBC6 20 DA FD   614      JSR PRBYT
OBC9 C8          615      INY
OBCA C4 94      616      CPY OFF
OBCC DO CC      617      BNE NPRQ
OBCE 60          618 RS     RTS        ;RTS IF END OF ENTRY REACHED
OBCF            619      ;
OBCF            620      ; * ITAB:SET TAB FOR PRINTER OR VIDEO AND
OBCF            621      ; * INIT ADDRESS COUNTER
OBCF            622      ;
OBCF A5 24      623 ITAB    LDA CH
OBD1 2C 10 08   624 ITAB1   BIT PRFLG   ;PRINTER ON?
OBD4 10 02      625      BPL STCH    ;BRANCH IF NOT
OBD6 A9 1C      626      LDA #S1C   ;SET TAB FOR PRINTER
OBD8 85 24      627 STCH    STA CH
OBD A9 00       628      LDA #S00   ;INIT ADDRESS COUNTER
OBD C 85 97     629      STA ACNT
OBDE 60         630      RTS
OBD F           631      ;
OBD F           632      ; * CHKR:CHECK IF END OF TABLE REACHED AND RTS IF SO
OBD F           633      ; * IF NOT, ADJUST TSP
OBD F           634      ;
OBD F A0 02     635 CHKR    LDY #S02
OBE1 20 1C OC   636      JSR CFF1
OBE4 C5 8F      637      CMP END+1
OBE6 DO 1C      638      BNE ATSP
OBE8 E4 8E      639      CPX END
OBEA DO 18      640      BNE ATSP   ;BRANCH ON END OF TABLE
OBE C A5 96     641      LDA TFUL   ;CHECK WHETHER TABLE FULL
OBE E 05 95     642      ORA EOP   ;OR END OF PROGRAM REACHED
OBF0 FO 10      643      BEQ ITBL   ;BRANCH IF NOT
OBF2 68         644      PLA
OBF3 68         645      PLA
OBF4 A2 01      646      LDX #S01
OBF6 B5 3A      647 APCR    LDA PC,X
OBF8 95 82      648      STA PC2,X
OBF A B5 07     649      LDA PCU,X

```

```

OBFC 95 86      650          STA PCU2,X          ;ELSE
OBFE CA        651          DEX                ;SAVE PRINT COUNTERS
OBFF 10 F5     652          BPL APCR             ;AND RTS TO MAIN PROGRAM
OC01 60        653          RTS
OC02 E6 98     654 ITBL    INC ETBL             ;SET END OF TABLE FLAG
OC04 86 05     655 ATSP    STX TSP
OC06 85 06     656          STA TSP+1
OC08 60        657          RTS
OC09          658          ;
OC09          659          ; * SPCN:INIT PROGRAM COUNTERS
OC09          660          ;
OC09 A0 01     661 SPCN    LDY #S01
OC0B B5 80     662 SPC1    LDA PC1,X
OC0D 99 3A 00  663          STA PC,Y
OC10 B5 84     664          LDA PCU1,X
OC12 99 07 00  665          STA PCU,Y
OC15 CA        666          DEX
OC16 88        667          DEY
OC17 10 F2     668          BPL SPC1
OC19 60        669          RTS
OC1A          670          ;
OC1A          671          ; * CFFF:CHECK WHETHER (TSP),6,7=$FFFF
OC1A          672          ;
OC1A A0 06     673 CFFF    LDY #S06
OC1C B1 05     674 CFF1    LDA (TSP),Y
OC1E AA        675          TAX
OC1F C8        676          INY
OC20 B1 05     677          LDA (TSP),Y
OC22 C9 FF     678          CMP #SFF
OC24 D0 02     679          BNE REET
OC26 E0 FF     680          CPX #SFF
OC28 60        681 REET    RTS
OC29          682          ;
OC29          683          ; * PONOF: PRINTER ON/OFF ROUTINE
OC29          684          ; * X=1 ACTIVATES PRINTER, X=0 DEACTIVATES PRINTER
OC29          685          ;
OC29 AD 10 08  686 PONOF   LDA PRFLG          ;DO NOTHING IF PRINTER FLAG
OC2C FO 1D     687          BEQ RTS             ;IS OFF
OC2E AD 13 08  688          LDA CSND          ;SEND CHAR?
OC31 FO 09     689          BEQ SLDV          ;BRANCH IF NOT
OC33 BD 11 08  690          LDA PNTL,X         ;LOAD CHAR AND
OC36 4C ED FD  691          JMP COUT          ;SEND TO PRINTER
OC39 4C 95 FE  692 VIDP    JMP OUTP          ;ACTIVATE SLOT
OC3C 8A        693 SLDV    TXA
OC3D FO FA     694          BEQ VIDP          ;BRANCH IF PRINTER OFF
                                COMMAND
OC3F AD 11 08  695          LDA PNTL
OC42 AE 12 08  696          LDX PNT1
OC45 FO F2     697          BEQ VIDP          ;BRANCH IF INTERFACE CARD
OC47 85 36     698          STA CSWL          ;ACTIVATE PRINTER ROUTINE
OC49 86 37     699          STX CSWL+1
OC4B 60        700 RTTS    RTS
OC4C          701          ;
OC4C          702          ; * END OF PROGRAM
OC4C          703          ;
OC4C          704          END

```

***** END OF ASSEMBLY

IBRUN SORT,D2
BRUN SORT,D2
SYMBOL TABLE SORTED ALPHABETICALLY

ALL	003C	A2L	003E	A4L	0042	ACNT	0097	AIT	0869
AMAX	0817	ANP	0909	APASS	0A6F	APCR	0BF6	ASK	0B47
AST	007E	ATSP	0C04	ATSP1	0967	ATSP2	0966	BEGIN	0B2E
CFF1	0C1C	CFFF	0C1A	CH	0024	CHAR1	F98A	CHAR2	F9BA
CHEK	0B90	CHKR	0BDF	CHT	0A41	CLKBD	C010	CLSC	FC58
CNTR	0093	CON	0A90	COUT	FDED	CP1	08E8	CPR	08EA
CROUT	FD8E	CSND	0813	CSWL	0036	DISA	098F	DNI	08FE
EAR	0003	EMNO	0A29	END	008E	ENF	0957	ENFL	0972
EOP	0095	EOT	008A	EOT1	0814	ESC	009B	ETBL	0098
FF	008C	FMIN	F88C	FORM	002E	FOUN	093E	HEAD	0818
HULP	0090	IFR	0831	INFO	0B95	IRUNT	095D	ITAB	0BCF
ITABL	0BD1	ITBL	0C02	KBD	C000	KLR	098E	LEN	002F
LM	002C	M1	09CA	M2	09CE	MERGE	0AB2	MFUR	08AC
MNML	F9C0	MNMR	FA00	MPBY	0A4E	NBLK	0BC1	NCRT	0BB2
NEF	0940	NEL	0B2E	NFND	0AA4	NFUL	0AD2	NIR	0A8B
NLA	0896	NLP	08C8	NOBL	09AD	NPR	0A55	NPRQ	0B9A
NRDY	0893	NZP	0931	OFF	0094	OFF1	0816	OOP	0A33
OUT	09FB	OUTP	FE95	PAD	0B74	PAI	0B81	PASS	0000
PC	003A	PC1	0080	PC2	0082	PCA3	0A63	PCA4	0A69
PCAD	0A60	PCADJ	F953	PCU	0007	PCU1	0084	PCU2	0086
PINT	0B9F	PNTH	0812	PNTL	0811	PONOF	0C29	POUT	088E
PR	0ACB	PRAD1	09E6	PRAD2	09EA	PRAD3	0A06	PRAD4	0A0B
PRAD5	0A11	PRBAK	F948	PRBK	09AA	PRBL2	F94A	PRBYT	FDDA
PRFLG	0810	PRINT	0B26	PROP	09A2	PRT	0912	PRYX	0A21
PRYX2	FD96	PZER	0B3D	PZERT	0B4C	RANGE	0A78	REET	0C28
REK	0AE6	RET	0AD6	RETR	0971	RM	002D	RS	0BCE
RTS3	0A5F	RTS4	0A6E	RTS5	0AA3	RTSS	0B25	RTTS	0C4B
RUNT	008C	SAR	0001	SAR1	082C	SAVX	0092	SEAR	0A8C
SLDV	0C3C	SOT	0088	SPC1	0C0B	SPCN	0C09	SPTA	0A3F
STCH	0BD8	STOR	08B1	TFUL	0096	TSP	0005	VIDP	0C39
XASM	08A1	XASS	09E2	YFULL	0B0F				

SYMBOL TABLE SORTED BY ADDRESS

PASS	0000	SAR	0001	EAR	0003	TSP	0005	PCU	0007
CH	0024	LM	002C	RM	002D	FORM	002E	LEN	002F
CSWL	0036	PC	003A	ALL	003C	A2L	003E	A4L	0042
AST	007E	PC1	0080	PC2	0082	PCU1	0084	PCU2	0086
SOT	0088	EOT	008A	RUNT	008C	FF	008C	END	008E
HULP	0090	SAVX	0092	CNTR	0093	OFF	0094	EOP	0095
TFUL	0096	ACNT	0097	ETBL	0098	ESC	009B	PRFLG	0810
PNTL	0811	PNTH	0812	CSND	0813	EOT1	0814	OFF1	0816
AMAX	0817	HEAD	0818	SAR1	082C	BEGIN	082E	IFR	0831
AIT	0869	POUT	088E	NRDY	0893	NLA	0896	XASM	08A1
MFUR	08AC	STOR	08B1	NLP	08C8	CP1	08E8	CPR	08EA
DNI	08FE	ANP	0909	PRT	0912	NZP	0931	FOUN	093E
NEF	0940	ENF	0957	IRUNT	095D	ATSP2	0966	ATSP1	0967
RETR	0971	ENFL	0972	KLR	098E	DISA	098F	PROP	09A2
PRBK	09AA	NOBL	09AD	M1	09CA	M2	09CE	XASS	09E2
PRAD1	09E6	PRAD2	09EA	OUT	09FB	PRAD3	0A06	PRAD4	0A0B
PRAD5	0A11	PRYX	0A21	EMNO	0A29	OOP	0A33	SPTA	0A3F
CHT	0A41	MPBY	0A4E	NPR	0A55	RTS3	0A5F	PCAD	0A60
PCA3	0A63	PCA4	0A69	RTS4	0A6E	APASS	0A6F	RANGE	0A78
NIR	0A8B	SEAR	0A8C	CON	0A90	RTS5	0AA3	NFND	0AA4
MERGE	0AB2	PR	0ACB	NFUL	0AD2	RET	0AD6	REK	0AE6
YFULL	0B0F	RTSS	0B25	PRINT	0B26	NEL	0B2E	PZER	0B3D
ASK	0B47	PZERT	0B4C	PAD	0B74	PAI	0B81	CHEK	0B90
INFO	0B95	NPRQ	0B9A	PINT	0B9F	NCRT	0BB2	NBLK	0BC1
RS	0BCE	ITAB	0BCF	ITABL	0BD1	STCH	0BD8	CHKR	0BDF
APCR	0BF6	ITBL	0C02	ATSP	0C04	SPCN	0C09	SPC1	0C0B
CFFF	0C1A	CFF1	0C1C	REET	0C28	PONOF	0C29	VIDP	0C39
SLDV	0C3C	RTTS	0C4B	KBD	C000	CLKBD	C010	FMIN	F88C
PRBAK	F948	PRBL2	F94A	PCADJ	F953	CHAR1	F98A	CHAR2	F9BA
MNML	F9C0	MNMR	FA00	CLSC	FC58	CROUT	FD8E	PRYX2	FD96
PRBYT	FDDA	COUT	FDED	OUTP	FE95				

A Fast Fractional Math Package for 6502 Microcomputers

by Wes Huntress

Implemented for the Apple II computer, these routines can be used by any 6502 microcomputer to obtain fast fractional arithmetic from assembly language.

Have you ever faced the problem of wanting to use fractions or decimal arithmetic when only Integer BASIC was available? Have you ever wanted to use trigonometric or complex math functions with Integer BASIC? Or have you ever faced the opposite problem with Applesoft — complex math a snap, but if only it was as fast as Integer? If the former was your problem, then you probably upgraded your Apple II from Integer to Applesoft. If you did, or bought an Apple II Plus in the first place, then you may have come across the second problem at one time or another.

Applesoft provides floating point math with 9-digit accuracy including trigonometric functions. These features are superb for most applications requiring complex mathematics, but much slower compared to integer arithmetic. In some speed-critical applications, such as the projection and animation of high-resolution 3-D images, Applesoft is often simply too slow. In the case of 3-D animation, this results in a slow frame projection rate. The only way to improve the speed at present is to access Applesoft math subroutines directly from assembly language and thereby avoid the interpreter overhead.

If you are not a machine-language programmer, you can still increase execution speed of floating point math by using an Applesoft compiler. These compilers have just recently appeared on the software market and will convert your Applesoft program to a machine-language version which will run floating point math two to three times faster. The ultimate solution is to use an arithmetic processor board where the math routines are implemented in hardware. These boards are available, but at a price, and not every Apple owner will have one. Therefore, if you are writing software for a general audience, these peripheral boards are not the solution.

There is an alternate approach to getting a significant increase in math speed for Apple users with standard hardware configurations. The solution is to write an assembly-language math package that contains complex math functions but is built for speed rather than accuracy. One way would be to rewrite the Applesoft floating point math package to use 3-byte or 4-byte numbers instead of the standard Applesoft 5-byte format. The floating point routines in the Integer ROMs use a 4-byte format. Floating point math in any format is still significantly slower than integer math, so that if speed is the utmost consideration, then some form of integer math must be used. Use of integer math to gain speed requires only that we give up the ability in floating point math to represent very large or very small numbers. It is possible to represent fractional or decimal numbers with an integer format. The limitation to accuracy is the number of bytes used to represent a number.

The assembly-language routines presented in this article provide a very fast 3-byte (24-bit) integer math package which is capable of representing fractional numbers. Complex math functions, such as the trigonometric operators, have been implemented. The routines work in the same way as standard 2-byte multiple-precision integer arithmetic except that a third byte is included to represent the fractional part of a number. The first byte of the 3-byte number represents the fractional part, and the next two bytes are the integer part of the number in the familiar byte-swapped format. Examples of 3-byte fractional numbers are:

01 01 01	=	257 1/256	=	257.004
FF 40 00	=	64 255/256	=	64.996
24 03 00	=	3 36/256	=	3.141

The accuracy in the fractional part is one part in 256, or in decimal form 0.004. While this is not at all competitive with the accuracy of Applesoft, it may be all that is required in some applications and is the fastest possible fractional arithmetic in software. The accuracy could be improved by adding multiple-precision fractional parts, but this would soon lose efficiency compared to floating point routines. The numbers are signed so that the largest positive number which can be represented is 32767.996, and the largest negative number is -32768.996. The smallest numbers which can be represented are +/- 0.004.

The Fractional Integer Arithmetic (FIAT) package is intended to be tucked between DOS and its buffers. It is invisible to DOS and both BASICS. Figure 1 is a memory map showing where the FIAT code is located. FIAT contains its own variable space in page \$98. At three bytes per variable, there is room for 85 variables and constants. This is sufficient for most applications.

To use FIAT from machine language it is easiest to think of it in terms of a pseudo-processor. FIAT has a set of 3-byte registers through which all operations are performed. The "op-codes" are subroutine calls (JSRs) to load these registers, operate on their contents, and move their contents to other registers or to memory. Figure 2 illustrates the programming model for FIAT.

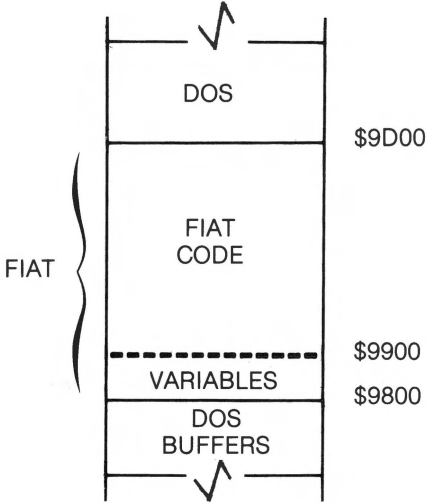

Figure 1: FIAT Memory Map

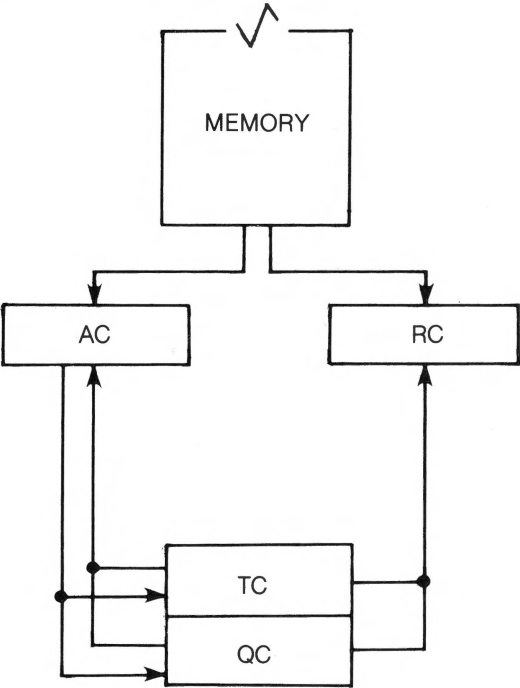

Figure 2: FIAT Programming Model

There are two main registers used in accessing memory and in arithmetic operations. The "AC" register, or accumulator, is the principal working register. All functions operate on the number in the AC register, and the results of all arithmetic operations are left in the AC register. Numbers can be transferred both to and from the AC register and memory. The usual program sequence for using an operator with single operand (a "unary" operator) such as SGN, ABS, INT, SIN, etc., is to first transfer a 3-byte number into the AC register, then call the arithmetic operator, and finally transfer the result from the AC register.

The RC register is used only for those operations requiring two operands ("binary" operators): ADD, SUB, MUL, DIV, and CMP. For these operations, one operand is placed in the AC register and the other in the RC register. Numbers can be moved into, but not out of, the RC register. The order of the operations is: AC SUB(tract) RC, AC DIV(ided by) RC, and AC CMP(ared to) RC. The result of ADD, SUB, MUL and DIV is left in the AC register. The CMP operator conditions the accumulator of the 6502.

The TC and QC registers are provided for storage of intermediate results. Results can be moved into TC and QC from AC, and back from TC or QC into AC or RC. Some care must be exercised in using the TC and QC registers however, since the SQR function uses the TC register, and the TAN and ATN functions use both the TC and QC registers.

There is a fifth register, the SC register, which is an extension of the AC register. The AC register, including the SC register and an extension byte ACX, can be as wide as seven bytes, depending on the operation being performed. This is all transparent to the user. Operands are always loaded in the 3-byte AC register (ACL, ACM, ACH) and all results are found in the AC register.

Listing 1 is a source listing of FIAT outlining the function and usage of each operator. Any special entry or exit conditions are listed below the routine title. Listing 2 gives the entry points for each function and lists the 6502 and FIAT registers used. Listing 3 is a sample listing of an assembly language program which uses FIAT.

Most routines in FIAT have more than one entry point. The principal entry point assumes that the AC register (and RC register if required) has already been loaded. For unary operators, a second entry point is provided which will load a specified variable from memory into AC and then perform the operation. These entry points are labeled with a "#" suffix. For example, the sine operator has a principal entry point labeled SIN and a unary entry point labeled SIN#. The unary entry point in this case requires that the 6502 Y register point to the variable in page \$98.

Binary operators have three entry points. The principal entry point assumes that both the AC and RC registers are already loaded. The unary (suffix: "#") entry point loads the RC register with the variable indexed by the 6502 X register. The binary entry point, suffixed by "##", loads both the RC and AC registers. On binary entry, the 6502 X register points to the variable to be loaded into RC, and the 6502 Y register points to the variable to be loaded into AC.

The trig functions SIN, COS, and TAN in FIAT use degrees rather than radians. The unit angle is one degree. Positive angles, negative angles, and angles larger than 360 degrees can be input. Fractional angles will be converted to the nearest degree. The routine FXA can be used to reduce any angle to a positive value between 0 and 359.996 degrees.

The inverse trig functions ASN (arcsin), ACS (arccos), and ATN (arctan) are provided but are limited by the accuracy of the 1-byte fraction. To the accuracy available, the sines of 84, 85, and 86 degrees are all FF 00 00, and the sines of 87, 88, 89, and 90 degrees are all 00 01 00. Therefore ASN (FF 00 00) will return just 86 degrees and ASN (00 01 00) will return 90 degrees. This problem is only serious for angles near 90 degrees for the ASN operator, and for angles near 0 degrees for the ACS operator. The ATN function does not have this problem, but is accurate only to $+/-$ one degree over its whole range and is slower than ASN or ACS. The ASN and ATN operators return an angle between -90 and $+90$ degrees. The ACS operator returns an angle between 0 and 180 degrees.

Range checking to maximize speed is not provided for any of the operators. The user is responsible for insuring that the input is in the proper format (3-byte signed integer) and that the operation does not result in overflow. The INC, DEC, ADD and SUB operators will "wrap-around" on overflow. For example: 1 ADD 32767 = -32768 . A multiply which would result in a number with a value greater than 32767.996 or less than -32768.996 yields nonsense. A DIV by zero or INV zero yields nonsense. The SQR function returns the square root of an unsigned number for negative number input. The trig functions are more forgiving. SIN, COS, and TAN will accept any value and reduce it with FXA. ASN and ACS assume any values greater than $+/- 1.0$ to be equal to $+/- 1.0$. The ATN function accepts any value.

The improvement in speed gained by using FIAT instead of Applesoft floating point math is very large for all but the multiply and divide routines. For MUL and DIV the gain is a factor of about 5. For the ADD and SUB routines, the gain is a factor of 50. For INT, SGN, and ABS routines the gain is about 100. For the SQR, SIN, COS, and ASN (vs. derived Applesoft arcsin) the gain is about 200. For TAN and ATN the gain is about 40 and 20 respectively.

To make your own copy of FIAT, use your assembler to copy the source listing in listing 1 and assemble it at \$800. Get into the monitor and type in the data given in listing 4 for the sine table from \$80D to \$866. Now, from the monitor, type:

```
*98F3 < 800.BFFM < CR >
*98F3G < CR >
*BSAVE FIAT,A$98F3,L$3FF < CR >
```

To install FIAT, boot the system and type RUN FIAT-LOADER (listing 4).

Listing 1

```

0800      1 ;*****
0800      2 ;*
0800      3 ;* 24-BIT FRACTIONAL *
0800      4 ;* SIGNED INTEGER *
0800      5 ;* ARITHMETIC *
0800      6 ;*
0800      7 ;* BY WES HUNTRESS *
0800      8 ;*
0800      9 ;* COPYRIGHT (C) 1982 *
0800     10 ;* MICRO INK, INC. *
0800     11 ;* CHELMSFORD, MA 01824*
0800     12 ;* ALL RIGHTS RESERVED *
0800     13 ;*
0800     14 ;*****
0800     15 ;
0800     16 ;EQUATES
0800     17 ;
0800     18 ZP      EPZ 0
0800     19 QCL      EPZ $03
0800     20 QCM      EPZ QCL+1
0800     21 TCL      EPZ $07
0800     22 ACX      EPZ $F9
0800     23 ACL      EPZ ACX+1
0800     24 ACM      EPZ ACL+1
0800     25 ACH      EPZ ACM+1
0800     26 SCL      EPZ ACH+1
0800     27 SCM      EPZ SCL+1
0800     28 SCH      EPZ SCM+1
0800     29 RCL      EPZ $EB
0800     30 RCM      EPZ RCL+1
0800     31 RCH      EPZ RCM+1
0800     32 TMP      EPZ RCH+1
0800     33 CNT      EPZ TMP+1
0800     34 FLG      EPZ $CE
0800     35 FLH      EPZ $CF
0800     36 ;
0800     37 VAR      EQU $9800
0800     38 ;
0800     39          ORG $98F3
98F3     42 ;STUFF INTO DOS, RESET DOS PTRS
98F3     43 ;RESERVE VARIABLE SPACE
98F3     44 ;
98F3 A9D3     45          LDA #$D3
98F5 8D009D   46          STA $9D00
98F8 A997     47          LDA #$97
98FA 8D019D   48          STA $9D01
98FD 4CD4A7   49          JMP $A7D4
9900     50 ;
9900     51 ;RESERVE SIN TABLE SPACE
9900     52 ;
0867     53 TRG      DFS 90
995A     54 ;
995A     55 ;*****
995A     56 ;*
995A     57 ;* CLEAR: AC=0
995A     58 ;*
995A     59 ;*****
995A     60 ;
995A A000     61 CLR      LDY #0
995C 84FA     62          STY ACL
995E 84FB     63          STY ACM
9960 84FC     64          STY ACH
9962 60      65          RTS
9963     66 ;
9963     67 ;*****
9963     68 ;*
9963     69 ;* INCREMENT: AC=AC+1
9963     70 ;*
9963     71 ;*****
9963     72 ;
9963 205C9C   73 INC#    JSR TMA
9966 E6FB     74 INC      INC ACM
9968 D002     75          BNE ICO

```

```

996A E6FC      76          INC ACH
996C 60        77          ICO      RTS
996D          78          ;
996D          79          ;*****
996D          80          ;*
996D          81          ;* DECREMENT: AC=AC-1
996D          82          ;*
996D          83          ;*****
996D          84          ;
996D 205C9C    85          DEC#     JSR TMA
9970 38        86          DEC      SEC
9971 A5FB      87          LDA ACM
9973 E901      88          SBC #1
9975 85FB      89          STA ACM
9977 B002      90          BCS DCO
9979 C6FC      91          DEC ACH
997B 60        92          DCO     RTS
997C          93          ;
997C          94          ;*****
997C          95          ;*
997C          96          ;* INTEGER: AC=INT(AC+.5)
997C          97          ;*
997C          98          ;*****
997C          99          ;
997C          100         ;ROUNDS INSTEAD OF TRUNCATES
997C          101         ;
997C 205C9C    102         INT#     JSR TMA
997F 24FA      103         INT     BIT ACL
9981 1003      104         BPL INO
9983 206699    105         TNO     JSR INC
9986 A200      106         INO     LDX #0
9988 86FA      107         STX ACL
998A 60        108         TOK     RTS
998B          109         ;
998B          110         ;*****
998B          111         ;*
998B          112         ;* TRUNCATE: AC=INT(AC)
998B          113         ;*
998B          114         ;*****
998B          115         ;
998B          116         ;TRUNCATES AS PER BASIC "INT"
998B          117         ;
998B 205C9C    118         TNC#     JSR TMA
998E A5FA      119         TNC     LDA ACL
9990 F0F8      120         BEQ TOK
9992 24FC      121         BIT ACH
9994 10F0      122         BPL INO
9996 30EB      123         BMI TNO
9998          124         ;
9998          125         ;*****
9998          126         ;*
9998          127         ;* ADD: AC=AC+RC
9998          128         ;*
9998          129         ;*****
9998          130         ;
9998 205C9C    131         ADD##    JSR TMA
999B 206C9C    132         ADD##    JSR TMR
999E A2FD      133         ADD     LDX #$FD
99A0 18        134         CLC
99A1 B5FD      135         ADL     LDA SCL,X
99A3 75EE      136         ADC     TMP,X
99A5 95FD      137         STA     SCL,X
99A7 E8        138         INX
99A8 D0F7      139         BNE     ADL
99AA 60        140         RTS
99AB          141         ;
99AB          142         ;*****
99AB          143         ;*
99AB          144         ;* SUBTRACT: AC=AC-RC
99AB          145         ;*
99AB          146         ;*****
99AB          147         ;
99AB 205C9C    148         SUB##    JSR TMA
99AE 206C9C    149         SUB##    JSR TMR
99B1 A2FD      150         SUB     LDX #$FD

```

```

99B3 38      151      SEC
99B4 B5FD   152      SBL LDA SCL,X
99B6 F5EE   153      SBC TMP,X
99B8 95FD   154      STA SCL,X
99BA EB     155      INX
99BB D0F7   156      BNE SBL
99BD 60     157      RTS
99BE       158      ;
99BE       159      ;*****
99BE       160      ;* *
99BE       161      ;* SIGN: A REG = SGN(AC) *
99BE       162      ;* *
99BE       163      ;*****
99BE       164      ;
99BE       165      ; A REG CONDITIONED BY SIGN:
99BE       166      ;
99BE       167      ;A=0 FOR AC=0
99BE       168      ;A=1 FOR AC>0
99BE       169      ;A=FF FOR AC<0
99BE       170      ;
99BE 205C9C 171      SGN# JSR TMA
99C1 A5FC   172      SGN LDA ACH
99C3 3033   173      BMI CMI
99C5 D008   174      BNE CPL
99C7 A5FB   175      LDA ACM
99C9 D004   176      BNE CPL
99CB A5FA   177      LDA ACL
99CD F024   178      BEQ CEQ
99CF A901   179      CPL LDA #1
99D1 60     180      RTS
99D2       181      ;
99D2       182      ;*****
99D2       183      ;* *
99D2       184      ;* COMPARE: A REG = (AC)CMP(RC) *
99D2       185      ;* *
99D2       186      ;*****
99D2       187      ;
99D2       188      ;A REG CONDITIONED BY COMPARE:
99D2       189      ;
99D2       190      ;A=0 FOR AC=RC
99D2       191      ;A=1 FOR AC>RC
99D2       192      ;A=FF FOR AC<RC
99D2       193      ;
99D2 205C9C 194      CMP## JSR TMA
99D5 206C9C 195      CMP## JSR TMR
99D8 A202   196      CMP LDX #2
99DA A5FC   197      LDA ACH
99DC 3006   198      BMI CMX
99DE A4ED   199      LDY RCH
99E0 100A   200      BPL CLQ
99E2 30EB   201      BMI CPL
99E4 A4ED   202      CMX LDY RCH
99E6 3004   203      BMI CLQ
99E8 100E   204      BPL CMI
99EA B5FA   205      CLP LDA ACL,X
99EC D5EB   206      CLQ CMP RCL,X
99EE D006   207      BNE CNE
99FO CA     208      DEX
99F1 10F7   209      BPL CLP
99F3 A900   210      CEQ LDA #0
99F5 60     211      RTS
99F6 B0D7   212      CNE BCS CPL
99F8 A9FF   213      CMI LDA #$FF
99FA 60     214      RTS
99FB       215      ;
99FB       216      ;*****
99FB       217      ;* *
99FB       218      ;* ABSOLUTE VALUE: AC=ABS(AC) *
99FB       219      ;* CHANGE SIGN: AC=-AC *
99FB       220      ;* *
99FB       221      ;*****
99FB       222      ;
99FB 205C9C 223      CHG# JSR TMA
99FE 4C089A 224      JMP CHG
9A01       225      ;

```

```

9A01 205C9C 226 ABS# JSR TMA
9A04 227 ;
9A04 228 ;ABSOLUTE VALUE
9A04 229 ;
9A04 24FC 230 ABS BIT ACH
9A06 100E 231 BPL C40
9A08 232 ;
9A08 233 ;CHANGE SIGN
9A08 234 ;
9A08 A2FD 235 CHG LDX # $FD
9A0A 38 236 SEC
9A0B B5FD 237 C4L LDA SCL,X
9A0D 49FF 238 EOR # $FF
9A0F 6900 239 ADC #0
9A11 95FD 240 STA SCL,X
9A13 E8 241 INX
9A14 D0F5 242 BNE CHL
9A16 60 243 C40 RTS
9A17 244 ;
9A17 245 ;*****
9A17 246 ;* *
9A17 247 ;* MULTIPLY: AC=AC*RC *
9A17 248 ;* *
9A17 249 ;*****
9A17 250 ;
9A17 205C9C 251 MUL## JSR TMA
9A1A 206C9C 252 MUL# JSR TMR
9A1D 20009B 253 MUL JSR CKS ;NEG # ?
9A20 A5FA 254 MUL1 LDA ACL
9A22 85F9 255 STA ACX
9A24 A5FB 256 LDA ACM
9A26 85FA 257 STA ACL
9A28 A5FC 258 LDA ACH
9A2A 85FB 259 STA ACM
9A2C A018 260 LDY #24
9A2E A900 261 LDA #0
9A30 85FC 262 STA ACH
9A32 85FD 263 STA SCL
9A34 85FE 264 STA SCM
9A36 A5F9 265 MSHL LDA ACX
9A38 4A 266 LSR
9A39 9013 267 BCC MROR
9A3B 18 268 CLC
9A3C A5FC 269 LDA ACH
9A3E 65EB 270 ADC RCL
9A40 85FC 271 STA ACH
9A42 A5FD 272 LDA SCL
9A44 65EC 273 ADC RCM
9A46 85FD 274 STA SCL
9A48 A5FE 275 LDA SCM
9A4A 65ED 276 ADC RCH
9A4C 85FE 277 STA SCM
9A4E 66FE 278 MROR ROR SCM
9A50 66FD 279 ROR SCL
9A52 66FC 280 ROR ACH
9A54 66FB 281 ROR ACM
9A56 66FA 282 ROR ACL
9A58 66F9 283 ROR ACX
9A5A 88 284 DEY
9A5B D0D9 285 BNE MSHL
9A5D A6CE 286 LDX FLG
9A5F F003 287 BEQ MLO

9A61 20089A 288 JSR CHG ;FIX FOR NEG #
9A64 60 289 MLO RTS
9A65 290 ;
9A65 291 ;*****
9A65 292 ;* *
9A65 293 ;* DIVIDE: AC=AC/RC *
9A65 294 ;* *
9A65 295 ;*****
9A65 296 ;
9A65 205C9C 297 DIV## JSR TMA
9A68 206C9C 298 DIV# JSR TMR
9A6B 20009B 299 DIV JSR CKS ;NEG # ?
9A6E A5FC 300 DIV1 LDA ACH

```

```

9A70 85FD 301 STA SCL
9A72 A5FB 302 LDA ACM
9A74 85FC 303 STA ACH
9A76 A5FA 304 LDA ACL
9A78 85FB 305 STA ACM
9A7A A018 306 DIV2 LDY #24
9A7C 84EF 307 STY CNT
9A7E A900 308 LDA #0
9A80 85FA 309 STA ACL
9A82 85FE 310 STA SCM
9A84 85FF 311 STA SCH
9A86 06FA 312 DIVL ASL ACL
9A88 26FB 313 ROL ACM
9A8A 26FC 314 ROL ACH
9A8C 26FD 315 ROL SCL
9A8E 26FE 316 ROL SCM
9A90 26FF 317 ROL SCH
9A92 38 318 SEC
9A93 A5FD 319 LDA SCL
9A95 E5EB 320 SBC RCL
9A97 AA 321 TAX
9A98 A5FE 322 LDA SCM
9A9A E5EC 323 SBC RCM
9A9C A8 324 TAY
9A9D A5FF 325 LDA SCH
9A9F E5ED 326 SBC RCH
9AA1 9008 327 BCC DIVS
9AA3 86FD 328 STX SCL
9AA5 84FE 329 STY SCM
9AA7 85FF 330 STA SCH
9AA9 E6FA 331 INC ACL
9AAB C6EF 332 DIVS DEC CNT
9AAD D0D7 333 BNE DIVL
9AAF A6CE 334 LDX FLG
9AB1 F003 335 BEQ DVO
9AB3 20089A 336 JSR CHG ;FIX FOR NEG #
9AB6 60 337 DVO RTS
9AB7 338 ;
9AB7 339 ;*****
9AB7 340 ;* *
9AB7 341 ;* INVERT: AC=1/AC *
9AB7 342 ;* *
9AB7 343 ;*****
9AB7 344 ;
9AB7 205C9C 345 INV# JSR TMA
9ABA 20869C 346 INV JSR TAR
9ABD A900 347 LDA #0
9ABF 85FB 348 STA ACM
9AC1 85FD 349 STA SCL
9AC3 A901 350 LDA #1
9AC5 85FC 351 STA ACH
9AC7 20009B 352 JSR CKS
9ACA 4C7A9A 353 JMP DIV2
9ACD 354 ;
9ACD 355 ;*****
9ACD 356 ;* *
9ACD 357 ;* SQUARE ROOT: AC=SQR(AC) *
9ACD 358 ;* *
9ACD 359 ;*****
9ACD 360 ;
9ACD 361 ;NEWTON-RAPHSON SQUARE ROOT
9ACD 362 ;
9ACD 363 ;STORE ARGUMENT
9ACD 364 ;AND LOOP COUNT
9ACD 365 ;
9ACD 205C9C 366 SQR# JSR TMA
9AD0 20909C 367 SQR JSR TAT
9AD3 A910 368 LDA #$10
9AD5 85EE 369 STA TMP
9AD7 370 ;
9AD7 371 ;INITIAL GUESS = 0
9AD7 372 ;
9AD7 A900 373 LDA #0
9AD9 85CE 374 STA FLG
9ADB 85EB 375 STA RCL

```

```

9ADD 85ED 376 STA RCH
9ADF 85EC 377 STA RCM
9AE1 378 ;
9AE1 379 ;ADD GUESS TO ARG/GUESS
9AE1 380 ;AND DIVIDE BY TWO
9AE1 381 ;
9AE1 209E99 382 SQL JSR ADD
9AE4 18 383 CLC
9AE5 66FC 384 ROR ACH
9AE7 66FB 385 ROR ACM
9AE9 66FA 386 ROR ACL
9AEB 387 ;
9AEB 388 ;GUESS = OLD GUESS ?
9AEB 389 ;
9AEB 20D899 390 JSR CMP
9AEE F00F 391 BEQ SQO
9AF0 C6EE 392 DEC TMP
9AF2 F00B 393 BEQ SQO
9AF4 394 ;
9AF4 395 ;STORE NEW GUESS
9AF4 396 ;
9AF4 20869C 397 JSR TAR
9AF7 398 ;
9AF7 399 ;FETCH ARGUMENT AND
9AF7 400 ;DIVIDE BY GUESS
9AF7 401 ;
9AF7 20A49C 402 JSR TTA
9AFA 206E9A 403 JSR DIV1
9AFD F0E2 404 BEQ SQL
9AFF 405 ;
9AFF 60 406 SQO RTS
9B00 407 ;
9B00 408 ;*****
9B00 409 ;*
9B00 410 ;* CHECK SIGN SUBROUTINE *
9B00 411 ;* FOR MULTIPLY AND DIVIDE *
9B00 412 ;*
9B00 413 ;*****
9B00 414 ;
9B00 A000 415 CKS LDY #0
9B02 24FC 416 BIT ACH
9B04 1004 417 BPL CKA
9B06 20089A 418 JSR CHG
9B09 88 419 DEY
9B0A 24ED 420 CKA BIT RCH
9B0C 100F 421 BPL CKB
9B0E C8 422 INY
9B0F A2FD 423 CGR LDX #$FD
9B11 38 424 SEC
9B12 B5EE 425 CKL LDA TMP,X
9B14 49FF 426 EOR #$FF
9B16 6900 427 ADC #0
9B18 95EE 428 STA TMP,X
9B1A E8 429 INX
9B1B D0F5 430 BNE CKL
9B1D 84CE 431 CKB STY FLG
9B1F 60 432 RTS
9B20 433 ;
9B20 434 ;*****
9B20 435 ;*
9B20 436 ;* FIX ANGLE SUBROUTINE: *
9B20 437 ;* INSURES 0 <= AC < 360 *
9B20 438 ;*
9B20 439 ;*****
9B20 440 ;
9B20 441 ;RC=360
9B20 442 ;
9B20 A900 443 FXA LDA #0
9B22 A268 444 LDX #104
9B24 A001 445 LDY #1
9B26 85EB 446 STA RCL
9B28 86EC 447 STX RCM
9B2A 84ED 448 STY RCH
9B2C 449 ;
9B2C 450 ;ANGLE NEGATIVE ?

```

76 Machine-Language Aids

```

9B2C      451 ;
9B2C A5FC  452 LDA ACH
9B2E 100A  453 BPL FXB ;NO
9B30      454 ;
9B30      455 ;FIX NEG ANGLE
9B30      456 ;ADD 360 UNTIL AC>=0
9B30      457 ;
9B30 209E99 458 FXN JSR ADD
9B33 AA    459 TAX
9B34 30FA  460 BMI FXN
9B36 60    461 RTS
9B37      462 ;
9B37      463 ;FIX POS ANGLE
9B37      464 ;SUB 360 UNTIL AC<360
9B37      465 ;
9B37 20B199 466 FXP JSR SUB
9B3A C901  467 FXB CMP #1 ;AC>360
9B3C 9008  468 BCC FXO
9B3E D0F7  469 BNE FXP ;YES
9B40 A5FB  470 LDA ACM
9B42 C968  471 CMP #104
9B44 B0F1  472 BCS FXP ;YES
9B46      473 ;
9B46      474 ;ANGLE OK
9B46      475 ;
9B46 60    476 FXO RTS
9B47      477 ;
9B47      478 ;*****
9B47      479 ;* *
9B47      480 ;* SINE: AC=SIN(AC) *
9B47      481 ;* *
9B47      482 ;*****
9B47      483 ;
9B47 205C9C 484 SIN# JSR TMA
9B4A 20209B 485 SIN JSR FXA
9B4D 207F99 486 JSR INT
9B50 A000  487 LDY #0
9B52 84CE  488 STY FLG ;SIGN +
9B54      489 ;
9B54      490 ;REDUCE ANGLE TO <= 90
9B54      491 ;
9B54 38    492 SEC
9B55 A5FC  493 LDA ACH
9B57 D006  494 BNE SNA ;AC>255
9B59 A5FB  495 LDA ACM
9B5B C9B5  496 CMP #181
9B5D 9008  497 BCC SNB ;AC<=180
9B5F A968  498 SNA LDA #104
9B61 E5FB  499 SBC ACM
9B63 85FB  500 STA ACM
9B65 C6CE  501 DEC FLG ;SIGN -
9B67 C95B  502 SNB CMP #91
9B69 9004  503 BCC SNG ;AC<=90
9B6B A9B4  504 LDA #180
9B6D E5FB  505 SBC ACM
9B6F      506 ;
9B6F      507 ;ANGLE IN A, GET AC=SIN(A)
9B6F      508 ;
9B6F 205A99 509 SNG JSR CLR
9B72 C957  510 CMP #87
9B74 9004  511 BCC SNT
9B76 E6FB  512 INC ACM ;A>86
9B78 1006  513 BPL SNS
9B7A AA    514 SNT TAX
9B7B BD0099 515 LDA TRG,X
9B7E 85FA  516 STA ACL
9B80      517 ;
9B80      518 ;NEG VALUE ?

9B80      519 ;
9B80 24CE  520 SNS BIT FLG
9B82 1003  521 BPL SNO
9B84 20089A 522 JSR CHG
9B87 60    523 SNO RTS
9B88      524 ;

```

```

9B88      525 ;*****
9B88      526 ;* *
9B88      527 ;* COSINE: AC=COS(AC) *
9B88      528 ;* *
9B88      529 ;*****
9B88      530 ;
9B88 205C9C 531 COS# JSR TMA
9B88 20ED9B 532 COS JSR CPA ;90-A
9B8E 4C4A9B 533 JMP SIN
9B91      534 ;
9B91      535 ;*****
9B91      536 ;* *
9B91      537 ;* TANGENT: AC=TAN(AC) *
9B91      538 ;* *
9B91      539 ;*****
9B91      540 ;
9B91 205C9C 541 TAN# JSR TMA
9B94 20909C 542 TAN JSR TAT
9B97 208B9B 543 JSR COS
9B9A 20C199 544 JSR SGN
9B9D D004 545 BNE TNQ
9B9F A902 546 LDA #2
9BA1 85FA 547 STA ACL
9BA3 209A9C 548 TNQ JSR TAQ
9BA6 20A49C 549 JSR TTA
9BA9 204A9B 550 JSR SIN
9BAC 20C29C 551 JSR TQR
9BAF 206B9A 552 JSR DIV
9BB2 60 553 RTS
9BB3      554 ;
9BB3      555 ;*****
9BB3      556 ;* *
9BB3      557 ;* ARCSINE: AC=ASN(AC) *
9BB3      558 ;* *
9BB3      559 ;*****
9BB3      560 ;
9BB3 205C9C 561 ASN# JSR TMA
9BB6 A000 562 ASN LDY #0
9BB8 84CE 563 STY FLG
9BBA A6FC 564 ASN1 LDX ACH
9BBC 1006 565 BPL ASC
9BBE 20089A 566 JSR CHG
9BC1 C6CE 567 DEC FLG
9BC3 AA 568 TAX
9BC4 D004 569 ASC BNE AOV
9BC6 C6FB 570 DEC ACM
9BC8 3004 571 BMI ASG
9BCA A25A 572 AOV LDX $$5A
9BCC 100C 573 BPL ASF
9BCE A257 574 ASG LDX $$57
9BD0 A5FA 575 LDA ACL
9BD2 CA 576 ASL DEX
9BD3 F005 577 BEQ ASF
9BD5 DD0099 578 CMP TRG,X
9BD8 90F8 579 BCC ASL
9BDA 205A99 580 ASF JSR CLR
9BDD 86FB 581 STX ACM
9BDF 24CE 582 BIT FLG
9BE1 1003 583 BPL ASO
9BE3 20089A 584 TNA JSR CHG
9BE6 60 585 ASO RTS
9BE7      586 ;
9BE7      587 ;*****
9BE7      588 ;* *
9BE7      589 ;* ARCCOSINE: AC=ACS(AC) *
9BE7      590 ;* *
9BE7      591 ;*****
9BE7      592 ;
9BE7 205C9C 593 ACS# JSR TMA
9BEA 20B69B 594 ACS JSR ASN ;AC=ASN
9BED      595 ;
9BED      596 ;AC=90-AC
9BED      597 ;
9BED 38 598 CPA SEC
9BEE A900 599 LDA #0

```

```

9BF0 E5FA 600 SBC ACL
9BF2 85FA 601 STA ACL
9BF4 A95A 602 LDA #90
9BF6 E5FB 603 SBC ACM
9BF8 85FB 604 STA ACM
9BFA A900 605 LDA #0
9BFC E5FC 606 SBC ACH
9BFE 85FC 607 STA ACH
9C00 60 608 RTS
9C01 609 ;
9C01 610 ;*****
9C01 611 ;* *
9C01 612 ;* ARCTANGENT: AC=ATN(AC) *
9C01 613 ;* *
9C01 614 ;*****
9C01 615 ;
9C01 205C9C 616 ATN# JSR TMA
9C04 20C199 617 ATN JSR SGN
9C07 85CF 618 STA FLH
9C09 85CE 619 STA FLG
9C0B 1003 620 BPL ATP
9C0D 20089A 621 JSR CHG
9C10 A5FC 622 ATP LDA ACH
9C12 D0B6 623 BNE AOV
9C14 A5FB 624 LDA ACM
9C16 30B2 625 BMI AOV
9C18 209A9C 626 JSR TAQ
9C1B 20869C 627 JSR TAR
9C1E A200 628 LDX #0
9C20 86CE 629 STX FLG
9C22 20209A 630 JSR MUL1
9C25 206699 631 JSR INC
9C28 20D09A 632 JSR SQR
9C2B A504 633 LDA QCM
9C2D D00E 634 BNE ATM
9C2F 20869C 635 JSR TAR
9C32 20B89C 636 JSR TQA
9C35 206E9A 637 JSR DIV1
9C38 20BA9B 638 JSR ASN1
9C3B 1006 639 BPL ATF
9C3D 20BA9A 640 ATM JSR INV
9C40 20EA9B 641 JSR ACS
9C43 24CF 642 ATF BIT FLH
9C45 1003 643 BPL ATO
9C47 20089A 644 JSR CHG
9C4A 60 645 ATO RTS
9C4B 646 ;
9C4B 647 ;*****
9C4B 648 ;* *
9C4B 649 ;* LET: VAR1=VAR2 *
9C4B 650 ;* *
9C4B 651 ;*****
9C4B 652 ;
9C4B 653 ;ENTRY: POINTER TO VAR#1 IN Y AND
9C4B 654 ;POINTER TO VAR#2 IN X
9C4B 655 ;
9C4B A903 656 LET## LDA #3
9C4D 85EF 657 STA CNT
9C4F BD0098 658 LTL LDA VAR,X
9C52 990098 659 STA VAR,Y
9C55 E8 660 INX
9C56 C8 661 INY
9C57 C6EF 662 DEC CNT
9C59 D0F4 663 BNE LTL
9C5B 60 664 RTS
9C5C 665 ;
9C5C 666 ;*****
9C5C 667 ;* *
9C5C 668 ;* FETCH AC: AC=VARIABLE *
9C5C 669 ;* *
9C5C 670 ;*****
9C5C 671 ;
9C5C 672 ;TRANSFERS VARIABLE TO AC
9C5C 673 ;ENTER WITH VAR PTR IN Y
9C5C 674 ;PROTECTS PTR IN X

```

```

9C5C      675      ;
9C5C B6EE    676      TMA      STX  TMP
9C5E A2FD    677      LDX  #$FD
9C60 B90098  678      MPL      LDA  VAR,Y
9C63 95FD    679      STA  SCL,X
9C65 C8      680      INY
9C66 E8      681      INX
9C67 D0F7    682      BNE  MPL
9C69 A6EE    683      LDX  TMP
9C6B 60      684      RTS
9C6C      685      ;
9C6C      686      ;*****
9C6C      687      ;*
9C6C      688      ;*  FETCH RC: RC=VARIABLE
9C6C      689      ;*
9C6C      690      ;*****
9C6C      691      ;
9C6C      692      ;TRANSFERS VARIABLE TO RC
9C6C      693      ;ENTER WITH VAR PTR IN X
9C6C      694      ;
9C6C 8A      695      TMR      TXA
9C6D A8      696      TAY
9C6E A2FD    697      LDX  #$FD
9C70 B90098  698      MRL      LDA  VAR,Y
9C73 95EE    699      STA  TMP,X
9C75 C8      700      INY
9C76 E8      701      INX
9C77 D0F7    702      BNE  MRL
9C79 60      703      RTS
9C7A      704      ;
9C7A      705      ;*****
9C7A      706      ;*
9C7A      707      ;*  STORE: VARIABLE=AC
9C7A      708      ;*
9C7A      709      ;*****
9C7A      710      ;
9C7A      711      ;STORES A RESULT FROM AC
9C7A      712      ;INTO A VARIABLE LOCATION
9C7A      713      ;
9C7A      714      ;ENTER WITH VAR PTR IN Y
9C7A      715      ;
9C7A A2FD    716      STR      LDX  #$FD
9C7C B5FD    717      STL      LDA  SCL,X
9C7E 990098  718      STA  VAR,Y
9C81 C8      719      INY
9C82 E8      720      INX
9C83 D0F7    721      BNE  STL
9C85 60      722      RTS
9C86      723      ;

9C86      724      ;*****
9C86      725      ;*
9C86      726      ;*  TRANSFER AC TO RC
9C86      727      ;*
9C86      728      ;*****
9C86      729      ;
9C86 A202    730      TAR      LDX  #2
9C88 B5FA    731      TRL      LDA  ACL,X
9C8A 95EB    732      STA  RCL,X
9C8C CA      733      DEX
9C8D 10F9    734      BPL  TRL
9C8F 60      735      RTS
9C90      736      ;
9C90      737      ;*****
9C90      738      ;*
9C90      739      ;*  TRANSFER AC TO TC
9C90      740      ;*
9C90      741      ;*****
9C90      742      ;
9C90 A202    743      TAT      LDX  #2
9C92 B5FA    744      TAL      LDA  ACL,X
9C94 9507    745      STA  TCL,X
9C96 CA      746      DEX
9C97 10F9    747      BPL  TAL
9C99 60      748      RTS

```

```

9C9A      749  ;
9C9A      750  ;*****
9C9A      751  ;*
9C9A      752  ;* TRANSFER AC TO QC
9C9A      753  ;*
9C9A      754  ;*****
9C9A      755  ;
9C9A A202  756  TAQ   LDX #2
9C9C B5FA  757  AQL   LDA ACL,X
9C9E 9503  758      STA QCL,X
9CA0 CA    759      DEX
9CA1 10F9  760      BPL AQL
9CA3 60    761      RTS
9CA4      762  ;
9CA4      763  ;*****
9CA4      764  ;*
9CA4      765  ;* TRANSFER TC TO AC
9CA4      766  ;*
9CA4      767  ;*****
9CA4      768  ;
9CA4 A202  769  TTA   LDX #2
9CA6 B507  770  TTL   LDA TCL,X
9CA8 95FA  771      STA ACL,X
9CAA CA    772      DEX
9CAB 10F9  773      BPL TTL
9CAD 60    774      RTS
9CAE      775  ;
9CAE      776  ;*****
9CAE      777  ;*
9CAE      778  ;* TRANSFER TC TO RC
9CAE      779  ;*
9CAE      780  ;*****
9CAE      781  ;
9CAE A202  782  TTR   LDX #2
9CB0 B507  783  TXL   LDA TCL,X
9CB2 95EB  784      STA RCL,X
9CB4 CA    785      DEX
9CB5 10F9  786      BPL TXL
9CB7 60    787      RTS
9CB8      788  ;
9CB8      789  ;*****
9CB8      790  ;*
9CB8      791  ;* TRANSFER QC TO AC
9CB8      792  ;*
9CB8      793  ;*****
9CB8      794  ;
9CB8 A202  795  TQA   LDX #2
9CBA B503  796  QAL   LDA QCL,X
9CBC 95FA  797      STA ACL,X
9CBE CA    798      DEX
9CBF 10F9  799      BPL QAL
9CC1 60    800      RTS
9CC2      801  ;
9CC2      802  ;*****
9CC2      803  ;*
9CC2      804  ;* TRANSFER QC TO RC
9CC2      805  ;*
9CC2      806  ;*****
9CC2      807  ;
9CC2 A202  808  TQR   LDX #2
9CC4 B503  809  QRL   LDA QCL,X
9CC6 95EB  810      STA RCL,X
9CC8 CA    811      DEX
9CC9 10F9  812      BPL QRL
9CCB 60    813      RTS
9CCC      814  ;
815      END

```

Listing 2

```

1 ;*****
2 ;*
3 ;* EQUATES FOR 24-BIT *
4 ;* MATH PACKAGE *
5 ;*****
6 ;
7 ;PRINCIPAL ENTRY POINTS
8 ;ASSUME AC (AND RC) LOADED
9 ;
10 CLR EQU $995A ;USES Y,AC
11 INC EQU $9966 ;USES AC
12 DEC EQU $9970 ;USES A,AC
13 INT EQU $997F ;USES X,AC
14 TNC EQU $998E ;USES A,X,AC
15 ADD EQU $999E ;USES A,X,AC
16 SUB EQU $99B1 ;USES A,X,AC
17 SGN EQU $99C1 ;USES A
18 CMP EQU $99D8 ;USES A,X,Y
19 ABS EQU $9A04 ;USES A,X,AC
20 CHG EQU $9A08 ;USES A,X,AC
21 MUL EQU $9A1D ;USES A,X,Y,AC,FLG
22 DIV EQU $9A6B ;USES A,X,Y,AC,FLG,CNT
23 INV EQU $9ABA ;USES A,X,Y,AC,RC,FLG,CNT
24 SQR EQU $9AD0 ;USES A,X,Y,AC,RC,TC,FLG,CNT,TMP
25 FXA EQU $9E20 ;USES A,X,Y,AC,RC
26 SIN EQU $9E4A ;USES A,X,Y,AC,RC,FLG
27 COS EQU $9E8B ;USES A,X,Y,AC,RC,FLG
28 TAN EQU $9B94 ;USES A,X,Y,AC,RC,TC,QC,FLG,CNT
29 ASN EQU $9BB6 ;USES A,X,Y,AC,FLG
30 ACS EQU $9BEA ;USES A,X,Y,AC,FLG
31 ATN EQU $9C04 ;USES A,X,Y,AC,RC,TC,QC,FLG,FLH,CNT,TMP
32 TMA EQU $9C5C ;Y>VAR. USES A,Y,AC,TMP
33 TMR EQU $9C6C ;X>VAR. USES A,X,Y,RC
34 STR EQU $9C7A ;Y>VAR. USES A,X,Y
35 TAR EQU $9C86 ;USES A,X,RC
36 TAT EQU $9C90 ;USES A,X,TC
37 TAQ EQU $9C9A ;USES A,X,TQ
38 TTA EQU $9CA4 ;USES A,X,AC
39 TTR EQU $9CAE ;USES A,X,RC
40 TQA EQU $9CB8 ;USES A,X,AC
41 TQR EQU $9CC2 ;USES A,X,RC
42
43 UNARY OPERATORS: LOADING ENTRY POINTS
44 LOADS AC WITH VARIABLE INDEXED BY Y-REG
45
46 INC# EQU $9963 ;Y>AC
47 DEC# EQU $996D ;Y>AC
48 INT# EQU $997C ;Y>AC
49 TNC# EQU $998B ;Y>AC
50 SGN# EQU $99BE ;Y>AC
51 ABS# EQU $9A01 ;Y>AC
52 CHG# EQU $99FB ;Y>AC
53 INV# EQU $9AE7 ;Y>AC
54 SQR# EQU $9ACD ;Y>AC
55 SIN# EQU $9B47 ;Y>AC
56 COS# EQU $9B88 ;Y>AC
57 TAN# EQU $9B91 ;Y>AC
58 ASN# EQU $9BB3 ;Y>AC
59 ACS# EQU $9BE7 ;Y>AC
60 ATN# EQU $9C01 ;Y>AC
61
62 ;BINARY OPERATORS: FULL LOADING ENTRY POINTS
63 ;LOADS AC WITH VARIABLE INDEXED BY Y-REG,AND
64 ;LOADS RC WITH VARIABLE INDEXED BY X-REG
65
66 ADD## EQU $9998 ;Y>AC, X>RC
67 SUB## EQU $99AB ;Y>AC, X>RC
68 CMP## EQU $99D2 ;Y>AC, X>RC
69 MUL## EQU $9A17 ;Y>AC, X>RC
70 DIV## EQU $9A65 ;Y>AC, X>RC
71 LET## EQU $9C4B ;Y=X. USES ONLY A,X,Y,CNT

```

```

72
73 ;BINARY OPERATORS:HALF LOADING ENTRY POINTS
74 ;LOADS RC WITH VARIABLE INDEXED BY X-REG
75 ;ASSUMES AC ALREADY LOADED
76 ;
77 ADD# EQU $999B ;X>RC
78 SUB# EQU $99AE ;X>RC
79 CMP# EQU $99D5 ;X>RC
80 MUL# EQU $9A1A ;X>RC
81 DIV# EQU $9A68 ;X>RC
82
83 END

```

Listing 3

```

0800      1  ;*****
0800      2  ;*                               *
0800      3  ;*   EXAMPLE CODE USING FIAT   *
0800      4  ;*                               *
0800      5  ;*****
0800      6  ;
0800      7  ;FIAT EQUATES
0800      8  ;
0800      9  INC     EQU $9966
0800     10  ADD     EQU $999E
0800     11  CMP     EQU $99D8
0800     12  DIV     EQU $9A6B
0800     13  SQR     EQU $9AD0
0800     14  STR     EQU $9C7A
0800     15  TAT     EQU $9C90
0800     16  TAQ     EQU $9C9A
0800     17  TTR     EQU $9CAE
0800     18  TQR     EQU $9CC2
0800     19  MUL#    EQU $9A1A
0800     20  SIN#    EQU $9B47
0800     21  SUB##   EQU $99AB
0800     22  MUL##   EQU $9A17
0800     23  LET##   EQU $9C4B
0800     24  ;
0800     25  ;VARIABLE EQUATES
0800     26  ;
0800     27  A       EPZ $00
0800     28  B       EPZ $03
0800     29  C       EPZ $06
0800     30  D       EPZ $09
0800     31  E       EPZ $0C
0800     32  F       EPZ $0F
0800     33  PI      EPZ $12
0800     34  ;
0800     35  ;B=(A-B)*C+1
0800     36  ;
0800  A000      37      LDY #A
0802  A203      38      LDX #B
0804  20AE99    39      JSR SUB##
0807  A206      40      LDX #C
0809  201A9A    41      JSR MUL#
080C  206699    42      JSR INC
080F  A003      43      LDY #B
0811  207A9C    44      JSR STR
0814      45  ;
0814      46  ;F=PI*SQR(A*B+C*D)/SIN(E)
0814      47  ;
0814  A00C      48      LDY #E
0816  20479E    49      JSR SIN#
0819  209A9C    50      JSR TAQ
081C  A000      51      LDY #A
081E  A203      52      LDX #B
0820  20179A    53      JSR MUL##
0823  20909C    54      JSR TAT
0826  A006      55      LDY #C
0828  A209      56      LDX #D

```

```

082A 20179A 57 JSR MUL##
082F 20AE9C 58 JSR TTR
0830 209E99 59 JSR ADD
0833 A212 60 LDX #PI
0835 201A9A 61 JSR MUL#
0838 20C29C 62 JSR TQR
083B 206B9A 63 JSR DIV
083E A00F 64 LDY #F
0840 207A9C 65 JSR STR
0843 66 ;
0843 67 ;IF A>B THEN C=B
0843 68 ;
0843 A003 69 LDY #B
0845 A200 70 LDX #A
0847 20D899 71 JSR CMP
084A 1007 72 BPL NO
084C A006 73 LDY #C
084E A209 74 LDX #D
0850 204B9C 75 JSR LET##
0853 60 76 NO RTS
0854 77 ;
0854 78 ;
          79 FND

```

```

10 REM *****
20 REM *
30 REM * FIAT LOADER *
40 REM *
50 REM * WES HUNTRESS *
60 REM *
70 REM * COPYRIGHT (C) 1982 *
80 REM * MICRO INK, INC. *
90 REM * CHELMSFORD, MA. 01824 *
92 REM *
94 REM *****
100 POKE - 25344,211
110 POKE - 25343,151
120 CALL - 22572
130 PRINT CHR$(4)"BLOAD FIAT"

```

Applesoft Error Messages from Machine Language

by Steve Cochard

The methods and data required to utilize Applesoft error messages in assembly language are presented. Use of these routines should be limited to assembly language routines that are interfaced with Applesoft programs.

I needed to know more about how Applesoft generates its error messages. While writing an assembly language program that interfaced with Applesoft, I found that just the simple "syntax error," which was the only message I knew how to utilize, was not enough.

I started my search for the "errors" by looking at the machine code for the "syntax error" message which is located at \$DEC9. It consists of only two commands:

```
LDX #$10  
JMP $D412
```

This short routine was intended only to load the X register with the starting address of the word SYNTAX in a table of all error messages. With a little more searching in the \$D412 routine, the table was found.

The 240-byte-long error message table is located at \$D260. By loading the X register with the appropriate index and then jumping to the \$D412 routine, it is possible to utilize any error message from machine language or Applesoft.

Table 1 shows the values to be loaded into the X register to generate any of the available 17 messages. Listings 1 and 2 show very short machine and Applesoft programs to verify that this is true. Listing 3 shows a program that will list the entire table.

Note that this procedure, if utilized in machine language, performs exactly as if the error had occurred in an Applesoft program. The error message is printed, the bell rings, the last executed line number is printed, and the program stops. If an ONERR GOTO statement was already executed, the program will again operate as if the error had occurred in Applesoft. The object line of the ONERR GOTO will be jumped to and executed. Happy Errors!

Table 1: Value of X register and error messages.

0	NEXT WITHOUT FOR	107	BAD SUBSCRIPT
16	SYNTAX	120	REDIM'D ARRAY
22	RETURN WITHOUT GOSUB	133	DIVISION BY ZERO
42	OUT OF DATA	149	ILLEGAL DIRECT
53	ILLEGAL QUANTITY	163	TYPE MISMATCH
69	OVERFLOW	176	STRING TOO LONG
77	OUT OF MEMORY	191	FORMULA TOO COMPLEX
90	UNDEF'D STATEMENT	210	CAN'T CONTINUE
		224	UNDEF'D FUNCTION

Listing 1: Enter from the monitor to interface with program listing 2.

```
300:LDX $0306
303:JMP $D412
```

Listing 2: Applesoft program to print error messages.

```
10 INPUT "WHAT VALUE OF X ? ";X
20 POKE 774,X
30 CALL 768
```

Listing 3: Lists the entire table. Enter it from the monitor and then type in 300G.

```
300:LDX #$00
302:LDA $D260,X
305:EOR #$80
307:BMI $0310
309:ORA #$80
30B:JSR $FDED
30E:LDA #$8D
310:JSR $FDED
313:INX
314:CPX #$FF
316:BNE $0302
318:RTS
```

3

I/O ENHANCEMENTS

Serial Line Editor <i>Wes Huntress</i>	89
Trick DOS <i>Sanford M. Mossberg</i>	100
LACRAB <i>N.R. McBurney</i>	107

I/O Enhancements

You can improve communication with your computer by using any of these handy programs.

Sandy Mossberg's "Trick DOS" will allow you to change DOS commands; as a result you can create abbreviations for the commands, or completely change them.

"Binary File Parameter List" by Clyde Camp not only gives you the ability to see the location of the default address for binary type files, but also displays their lengths. N.R. McBurney's "LACRAB," an effective Applesoft BASIC listing-formatter and cross-reference program, improves the look and readability of your listing. The program utilizes features such as single statement lines and logical indentation.

"Serial Line Editor" by Wes Huntress is an improvement over the monitor ROM line input routine. It provides a better delete and insert character routine (the line appears the way it is stored), move cursor to beginning or end of line command, move cursor to first occurrence of a specified character command, and other features. The author offers methods to interface the Line Editor to any Applesoft program.

Serial Line Editor

by Wes Huntress

This routine is an extended line editor that allows inserting, deleting, and several other features.

The GETLN machine-language routine replaces your Apple's line input routine (resident in monitor ROM). Both Applesoft and Integer BASICs call this routine for line input. The advantage of the alternate routine given here is the editing features it contains. The Apple monitor ESC editing features are very useful for editing BASIC program lines, but are not the best for editing text. The editing features in GETLN are typical of serial text line editing and could form the basis of any line-oriented text processing program. GETLN also allows the input of normally forbidden characters in Applesoft, such as the comma and colon.

All of these advantages are gained at a slight disadvantage in usage. Applesoft programs must be moved up two pages in memory and a few extra program steps are required instead of a simple INPUT statement. GETLN should be used only for string input and string editing. The version given here is for Applesoft. With a few changes it can be made to work for Integer as well.

When called, GETLN prompts for input and places the characters in the keyboard buffer at \$200.2FF. All editing is done on the characters placed in the keyboard buffer. On return from GETLN it is necessary to move the characters from the keyboard buffer to the memory space that is to be occupied by the string. For Applesoft, this requires that the location in memory of the string variable's address pointer be known. The method used to accomplish this is the same as given in *CONTACT#6*. A dummy variable is declared as the first variable in the program, i.e. X\$ = "", which assigns the two-byte variable name to the first two locations in memory at the LOMEM: pointer. The third location is assigned to the string length, and the fourth and fifth locations to the address of the string in memory, low byte first.

The LOMEM: pointer is at \$69-70, so that the address of the string X\$ can now be found indirectly from the LOMEM: pointer. A separate machine language program, called GI, is provided. It interfaces the GETLN routine with Applesoft programs by placing the address of the keyboard buffer and the buffer string length into the proper location for X\$ using the LOMEM: pointer.

The string X\$ is now assigned to the string in the keyboard buffer. In order to move it into the upper part of memory where Applesoft strings are normally stored, and to prevent the string from being clobbered the next time GETLN is called, the statement X\$=MID\$(X\$,1) is used. This statement performs a memory move from the present location of X\$ (the keyboard buffer) to the next available space in high memory, and is the key to the success of the interface of GETLN with Applesoft programs.

How to Use It

To use GETLN with Applesoft programs, both GI and GETLN must be present in memory. To set up your program and call for input, use the following procedure:

```

5 X$ = " ":REM FIRST VARIABLE DECLARATION
.
.
.
100 CALL 840:A$ = MID$(X$,1):REM KEYBOARD INPUT

```

Line 100 replaces the INPUT A\$ statement. CALL 834 is to the keyboard input entry point in the GI interface routine. Three other entry points are provided in the interface routine. The call

```
100 CALL 859:X$ = MID$(X$,1):REM DOS INPUT
```

replaces the INPUT A\$ statement when READING text files from the disk. A separate routine from the keyboard input routine is required for Applesoft programs since the DOS stores and outputs all text files in negative ASCII. The call

```
100 X$ = A$:CALL 806:REM PRINT
```

can be used in place of the PRINT A\$ statement to print all control characters in inverse video. Otherwise use the PRINT A\$ statement as usual. To recall a string for further editing, use

```
100 X$ = A$:CALL 813:A$ = MID$(X$,1):REM EDIT
```

The cursor will be placed on the screen at the beginning of the recalled string. Dimensioned strings can be used as well as simple strings. GETLN can also be used alone from assembly language using 800G. It will place the input string in the keyboard buffer in standard ASCII terminated by \$8D (CR).

GETLN occupies nearly two pages of memory from \$800 to \$9AF. Since Applesoft programs normally reside in this space, it is necessary to move your program up in memory to make room for GETLN. This is readily accomplished by two statements:

```
POKE 104,10:POKE 2560,0
```

This line must be executed either from immediate mode or from an EXEC file before loading the Applesoft program. The short interface routine occupies locations \$300 to \$360.

Editing Features

The following edit commands are implemented in GETLN. Except for the usual Apple ←, → and RETURN editing keys, all commands are initiated by hitting the ESC key.

→	Move cursor right, copy character
←	Move cursor left
RETURN	Terminate line, clear to end of page
ESC →	Initiate insert mode, ESC or RET to exit
ESC ←	Delete character, recursive
ESC sp bar	Move cursor to beginning (end) of line
ESC char	Move cursor to first occurrence of char
ESC ctrl-shift-M	Delete remainder of line

The first three commands operate just as in the Apple monitor line editor. The monitor ESC functions are replaced with the five ESC functions listed above. Use ESC → to insert characters at any place in the line. Use the usual monitor → and ← keys to position the cursor over the character where you wish to insert. ESC → will push right by one character the entire string beginning from the character under the cursor to the end of the line, leaving a blank under the cursor. As you type in new characters, the old right-hand string is continuously shifted right. The ← and → keys work on the inserted substring as before but will not allow editing left of the first inserted character. In the insert mode, → operates just like the space bar if keyed at the right-hand end of the substring. To terminate the insert mode, press ESC or RETURN. The old right-hand string is moved back one space for reconnection.

The ESC ← command deletes the character under the cursor and pulls left the entire string to the right of the cursor. The function is recursive, so that characters can continue to be deleted by repeated keying of the ← key. The first key pressed other than ← terminates the function.

The ESC space bar command moves the cursor to the end of the line. If the cursor is already at the end of the line, then it is moved to the beginning. This function allows rapid transport of the cursor to the beginning or end of the line.

The ESC char command moves the cursor right in the line to the first occurrence of the character key pressed after the escape key. If the character is not found before the end of the line, then the search branches to the beginning of the line. If the character is not found in the line, then the cursor is not moved.

The ESC ctrl-shift-M command deletes the entire line to the right of the cursor including the character under the cursor. This function allows excess garbage to be cleared from the line for editing readability.

Together these functions give you an intriguing and powerful text line editor. It's much more fun than the Apple monitor line input routine. Try it! You'll like it!

```

0800      1 ;*****
0800      2 ;*
0800      3 ;* SERIAL LINE EDITOR *
0800      4 ;*   FOR APPLESOFT   *
0800      5 ;*
0800      6 ;*           BY           *
0800      7 ;*
0800      8 ;*   WES HUNTRESS       *
0800      9 ;* SIERRA MADRE, CA   *
0800     10 ;*
0800     11 ;* COPYRIGHT (C) 1982 *
0800     12 ;* MICRO INK, INC.   *
0800     13 ;*CHELMSFORD, MA 01824*
0800     14 ;* ALL RIGHTS RESERVED*
0800     15 ;*
0800     16 ;*****
0800     17 ;
0800     18 ;EQUATES: CONSTANTS
0800     19 ;
0800     20 BS      EPZ $88
0800     21 CR      EPZ $8D
0800     22 CSM     EPZ $9D
0800     23 CTL     EPZ $20
0800     24 ESC     EPZ $9R
0800     25 FIX     EPZ $7F
0800     26 INV     EPZ $80
0800     27 NAK     EPZ $95
0800     28 BEND    EPZ $FE
0800     29 ZERO    EPZ $00
0800     30 BLANK   EPZ $A0
0800     31 ;
0800     32 ;EQUATES: POINTERS
0800     33 ;
0800     34 CHAR#   EPZ $19
0800     35 EOL     EPZ $1A
0800     36 STRT    EPZ $1B
0800     37 TEMP    EPZ $1C
0800     38 SUBSTR  EPZ $1D
0800     39 SUBEND  EPZ $1E
0800     40 MODE    EPZ $1F
0800     41 ;
0800     42 ;EQUATES: MONITOR ADDRESSES
0800     43 ;
0800     44 BUFFER  EQU $0200
0800     45 KEYIN  EQU $FDOC
0800     46 PRINT  EQU $FDED
0800     47 BACKSP EQU $FC10
0800     48 ADVANC EQU $FBF4
0800     49 RETURN EQU $FC62
0800     50 CLREOP EQU $FC42
0800     51 BELL   EQU $FF3A
0800     52 ;
0800     53         ORG $0800
0800     54 ;
0800     55 ;INITIALIZE KEYBOARD BUFFER
0800     56 ;
0800     57 GETLN  LDY #BLANK           ;LOAD BLANK CHARACTER
0802     58 CLRBR STY BUFFER         ;STORE IT IN KEYBOARD BUFFER
0805     59 INC   *- $2             ;FROM $0200
0808     60 BNE  CLRBR             ;TO $02FF
080A     61 LDX  #ZERO             ;SET POINTERS TO ZERO:
080C     62 STX  CHAR#            ;CHARACTER NUMBER IN THE STRING
080E     63 STX  EOL              ;END OF LINE POINTER
0810     64 STX  SUBSTRT          ;SUBSTRING START POINTER
0812     65 STX  SUBEND          ;SUBSTRING END POINTER
0814     66 STX  MODE             ;MAINLINE/SUBSTRING MODE FLAG
0816     67 ;
0816     68 ;MAINLINE CHARACTER ENTRY ROUTINE
0816     69 ;
0816     70 GETCHR JSR  KEYIN          ;GET CHAR USING MONITOR ROUTINE
0819     71 GETCH1 CMP  #BS          ;BACKSPACE?
081B     72 BEQ  BKSPCE            ;YES, GOTO BACKSPACE ROUTINE
081D     73 CMP  #ESC                ;ESCAPE KEY?
081F     74 BEQ  ESCAPE            ;YES, GOTO ESCAPE VECTOR ROUTINE

```

0821	C995	75	CMP #NAK	;FORWARD ARROW?
0823	F061	76	BEQ FORWRD	;YES, GOTO FORWARD ARROW ROUTINE
0825	C98D	77	CMP #CR	;RETURN?
0827	F063	78	BEQ LINEND	;YES, GOTO EXIT ROUTINE
0829	A619	79	LDX CHAR#	;NONE OF THESE, GET CURRENT CHAR#
082B	297F	80	AND #FIX	;FIX NEG ASCII INPUT FOR APPLESOFT
082D	204508	81	JSR STRPNT	;STORE AND PRINT CHAR
0830		82	;	
0830		83	; POINTER UPDATING	
0830		84	;	
0830	E619	85	FXPTRS INC CHAR#	;INC POSITION-IN-STRING POINTER
0832	A619	86	LDX CHAR#	;GET IT
0834	E41E	87	CPX SUBEND	;AT END OF SUBSTRING OR BUFFER?
0836	F076	88	BEQ WHICH	;YES, GO FIND OUT WHICH
0838	A41A	89	LDY EOL	;GET END OF LINE POINTER
083A	C419	90	CPY CHAR#	;END OF CURRENT LINE?
083C	B004	91	BCS FXPOUT	;NO, SKIP EOL POINTER UPDATE
083E	E61A	92	INC EOL	;INCREMENT END OF LINE POINTER
0840	F05F	93	BEQ BUFULL	;256 CHARS! GOTO BUFFER FULL
0842	4C1608	94	FXPOUT JMP GETCHR	;DONE. GET ANOTHER CHARACTER
0845		95	;	
0845		96	;STORE AND PRINT ROUTINE	
0845		97	;	
0845	9D0002	98	STRPNT STA BUFFER,X	;STORE IN CURRENT BUFFER LOC.
0848	C920	99	CMP #CTL	;CONTROL CHARACTER?
084A	9002	100	BCC PNT	;NO, SKIP TO PRINT
084C	0980	101	ORA #INV	;YES, CONVERT TO INVERSE
084E	20EDFD	102	PNT JSR PRINT	;PRINT TO SCREEN
0851	60	103	RTS	
0852		104	;	
0852		105	;ESCAPE KEY VECTOR ROUTINE	
0852		106	;	
0852	A41F	107	ESCAPE LDY MODE	;SUBSTRING MODE?
0854	D048	108	BNE SBEXV	;YES, GOTO SUBSTRING EXIT VECTOR
0856	200CFD	109	JSR KEYIN	;GET ANOTHER CHARACTER
0859	C995	110	CMP #NAK	;FORWARD ARROW?
085B	F00F	111	BEQ INSV	;YES, GOTO INSERT MODE VECTOR
085D	C988	112	CMP #BS	;BACKSPACE?
085F	F011	113	BEQ DELV	;YES, GOTO DELETE MODE VECTOR
0861	C9A0	114	CMP #BLANK	;SPACE CHAR?
0863	F00A	115	BEQ ZMMV	;YES, GOTO CURSOR ZOOM VECTOR
0865	C99D	116	CMP #CSM	;CTRL-SHIFT-M?
0867	F00C	117	BEQ ZAPV	;YES, GOTO LINE ZAP VECTOR
0869	4C7409	118	JMP CHRFDND	;NONE OF THESE, GOTO CHAR FIND
086C	4C0509	119	INSV JMP INSERT	;GOTO INSERT ROUTINE
086F	4C5509	120	ZMMV JMP ZOOM	;GOTO CURSOR ZOOM ROUTINE
0872	4CED08	121	DELV JMP DELETE	;GOTO DELETE ROUTINE
0875	4C9A09	122	ZAPV JMP ZAP	;GOTO DELETE-TO-EOL ROUTINE
0878		123	;	
0878		124	;BACKSPACE ROUTINE	
0878		125	;	
0878	A419	126	BKSPCE LDY CHAR#	;GET POSITION IN LINE
087A	C41D	127	CPY SUBSTRT	;AT BEGINNING OF LINE/SUBSTRING?
087C	F005	128	BEQ BSOUT	;YES, RETURN
087E	C619	129	DEC CHAR#	;NO, DECREMENT POSITION IN LINE
0880	2010FC	130	JSR BACKSP	;BACKSPACE CURSOR
0883	4C1608	131	BSOUT JMP GETCHR	;RETURN
0886		132	;	
0886		133	;FORWARD ARROW ROUTINE	
0886		134	;	
0886	20F4FB	135	FORWRD JSR ADVANC	;ADVANCE CURSOR
0889	4C3008	136	JMP FXPTRS	;RETURN TO INCREMENT CHAR#
088C		137	;	
088C		138	;EXIT ROUTINE	
088C		139	;	
088C	A41F	140	LINEND LDY MODE	;SUBSTRING MODE?
088E	D00E	141	BNE SBEXV	;YES, GOTO SUBSTRING EXIT
0890	A619	142	LDX CHAR#	;STORE CHARACTER COUNT
0892	861A	143	STX EOL	;IN EOL POINTER
0894	9D0002	144	STA BUFFER,X	;STORE CR AT END OF STRING
0897	2042FC	145	JSR CLRPOP	;CLEAR SCREEN TO END OF PAGE
089A	2062FC	146	JSR RETURN	;PERFORM CARRIAGE RETURN
089D	60	147	RTS	;EXIT TO CALLER
089E	4C3D09	148	SBEXV JMP SUBEXT	;GOTO SUBSTRING EXIT

```

08A1      149 ;
08A1      150 ;BUFFER FULL ROUTINE
08A1      151 ;
08A1 C61A  152 BUFULL DEC EOL ;DECREMENT EOL POINTER
08A3 C619  153 BUFULI DEC CHAR# ;DECREMENT CURSOR POSITION
08A5 2010FC 154 JSR BACKSP ;BACKSPACE
08A8 203AFF 155 BELEX JSR BELL ;SOUND BELL
08AB 4C1608 156 JMP GETCHR ;RETURN
08AE      157 ;
08AE      158 ;DETERMINE MAINLINE OR SUBSTRING MODE
08AE      159 ;
08AE A41F  160 WHICH LDY MODE ;SUBSTRING MODE?
08B0 F0F1  161 BEQ BUFULL ;NO, GOTO BUFFER END ROUTINE
08B2 4C1709 162 JMP MOVEFD ;YES, MOVE RIGHT STRING FORWARD
08B5      163 ;
08B5      164 ;MOVE STRING BACK ROUTINE
08B5      165 ;
08B5 A619  166 MOVEBK LDX CHAR# ;GET DESTINATION START
08B7 A41B  167 LDY STRT ;GET STRING START
08B9 A51A  168 LDA EOL ;GET STRING END
08BB 38    169 SEC
08BC E51B  170 SBC STRT ;SUBTRACT STRING START
08BE 18    171 CLC
08BF 6519  172 ADC CHAR# ;ADD PRESENT CURSOR POSITION
08C1 851C  173 STA TEMP ;STORE NEW EOL POINTER
08C3 B90002 174 MVBLP LDA BUFFER,Y ;GET STRING CHARACTER
08C6 204508 175 JSR STRPNT ;STORE AND PRINT CHARACTER
08C9 -C8   176 INY ;INCREMENT THE
08CA E8    177 INX ;POSITION POINTERS
08CB C41A  178 CPY EOL ;END OF STRING?
08CD 90F4  179 BCC MVBLP ;NO, GET ANOTHER CHARACTER
08CF 2042FC 180 JSR CLRPOP ;YES, CLEAR TO END OF PAGE
08D2 8A    181 TXA ;STORE CURSOR POSITION
08D3 A8    182 TAY ;IN Y REGISTER
08D4 A9A0  183 LDA #BLANK ;GET SPACE CHARACTER
08D6 9D0002 184 CLRLP STA BUFFER,X ;STORE IN BUFFER BEYOND NEW EOL
08D9 E8    185 INX ;INCREMENT POSITION
08DA E41A  186 CPX EOL ;AT OLD END OF LINE?
08DC 90F8  187 BCC CLRLP ;NO, DO IT AGAIN
08DE A61C  188 LDX TEMP ;YES, GET NEW EOL
08E0 861A  189 STX EOL ;STORE IT
08E2 98    190 TYA ;GET CURSOR POSITION
08E3 AA    191 TAX ;BACK INTO X REGISTER
08E4      192 ;
08E4      193 ;RESTORE CURSOR ROUTINE
08E4      194 ;
08E4 2010FC 195 RESTOR JSR BACKSP ;BACKSPACE
08E7 CA    196 DEX ;DECREMENT CURSOR POSITION
08E8 E419  197 CPX CHAR# ;AT PRESENT CHARACTER POSITION?
08EA D0F8  198 BNE RESTOR ;NO, DO IT AGAIN
08EC 60    199 RTS ;YES, RETURN
08ED      200 ;
08ED      201 ;DELETE ROUTINE
08ED      202 ;
08ED A619  203 DELETE LDX CHAR# ;GET PRESENT CHARACTER POSITION
08EF E8    204 INX ;INCREMENT TO NEXT CHARACTER
08F0 861B  205 STX STRT ;STORE STRING START POSITION
08F2 A41A  206 DELELP LDY EOL ;GET END OF LINE POINTER
08F4 C419  207 CPY CHAR# ;SAME AS NEXT CHARACTER POSITION?
08F6 F00A  208 BEQ DELOUT ;YES, NOTHING TO DELETE!
08F8 20B508 209 JSR MOVEBK ;NO, MOVE STRING BACK ONE SPACE
08FB 200CFD 210 JSR KEYIN ;GET ANOTHER CHARACTER
08FE C988  211 CMP #BS ;ANOTHER BACKSPACE CHARACTER?
0900 F0F0  212 BEQ DELELP ;YES, DELETE ANOTHER CHARACTER
0902 4C1908 213 DELOUT JMP GETCH1 ;NO, BACK TO MAINLINE
0905      214 ;
0905      215 ;INSERT ROUTINE INITIALIZE
0905      216 ;
0905 A61A  217 INSERT LDX EOL ;GET END OF LINE POINTER
0907 E0FE  218 CPX #BEND ;END OF ALLOWABLE INSERTIONS?
0909 B09D  219 BCS BELEX ;YES, STOP INPUT
090B A619  220 LDX CHAR# ;NO, GET POSITION IN LINE
090D E41A  221 CPX EOL ;AT END OF LINE?
090F F029  222 BEQ INOUT ;YES, NO NEED TO INSERT!
0911 861D  223 STX SUBSTR ;NO, STORE SUBSTRING START

```

```

0913 861E 224          STX SUBEND          ;STORE PRESENT SUBSTRING END
0915 851F 225          STA MODE            ;SET SUBSTRING MODE FLAG
0917          226          ;
0917          227          ;MOVE STRING FORWARD ROUTINE
0917          228          ;
0917 20F4FB 229        MOVEFD JSR ADVANC          ;ADVANCE CURSOR
091A BD0002 230        LDA BUFFER,X          ;GET FIRST STRING CHARACTER
091D E61A 231          INC EOL              ;INCREMENT EOL POINTER
091F F02E 232          BEQ SBOUT            ;BUFFER END! STOP INPUT
0921 E8 233           MVFLP INX              ;POINT TO SECOND CHARACTER
0922 BC0002 234        LDY BUFFER,X          ;GET SECOND CHARACTER
0925 204508 235        JSR STRPNT           ;STORE AND PRINT FIRST CHAR
0928 98 236           TYA                  ;TRANFER SECOND CHAR TO ACC.
0929 E41A 237          CPX EOL              ;END OF LINE?
092B D0F4 238          BNE MVFLP           ;NO, DO IT AGAIN
092D E8 239           INX                  ;YES
092E 20E408 240        JSR RESTOR          ;RESTORE CURSOR
0931 98 241           TYA                  ;GET SPACE CHAR INTO ACC.
0932 204508 242        JSR STRPNT           ;STORE & PRINT AT INSERT POSITION
0935 2010FC 243        JSR BACKSP          ;RETURN CURSOR TO INSERT POSITION
0938 E61E 244          INC SUBEND          ;INCREMENT SUBSTRING END POINTER
093A 4C1608 245        INOUT JMP GETCHR      ;GET ANOTHER CHAR
093D          246          ;
093D          247          ;SUBSTRING EXIT ROUTINE
093D          248          ;
093D A61E 249          SUBEXT LDX SUBEND      ;GET SUBSTRING END POSITION
093F 861B 250          STX STRT             ;STORE IN STRING START POINTER
0941 20B508 251        JSR MOVEBK          ;MOVE RIGHT STRING BACK
0944 A200 252          LDX #ZERO           ;RESET THE
0946 861D 253          STX SUBSTR          ;SUBSTRING START,
0948 861E 254          STX SUBEND          ;SUBSTRING END POINTERS
094A 861F 255          STX MODE            ;AND MODE FLAG
094C 4C1608 256        JMP GETCHR          ;BACK TO MAINLINE
094F 2010FC 257        SBOUT JSR BACKSP      ;BACKSPACE
0952 4CA108 258        JMP BUFULL         ;GOTO BUFFER FULL
0955          259          ;
0955          260          ;CURSOR ZOOM ROUTINE
0955          261          ;
0955 A51A 262          ZOOM LDA EOL          ;GET EOL POINTER
0957 F00E 263          BEQ ZMOUT           ;NULL LINE! RETURN
0959 AA 264           TAX                  ;STORE EOL IN X REGISTER
095A E519 265          SBC CHAR#           ;CURSOR AT END OF LINE?
095C F00C 266          BEQ ZBEG           ;YES, ZOOM TO LINE START
095E 8619 267          STX CHAR#           ;STORE CURSOR POSITION (EOL)
0960 AA 268           TAX                  ;GET ADVANCE COUNT IN X REGISTER
0961 20F4FB 269        ZOOLP JSR ADVANC      ;ADVANCE CURSOR
0964 CA 270           DEX                  ;DECREMENT ADVANCE COUNT
0965 D0FA 271          BNE ZOOLP           ;ADVANCE AGAIN IF NOT AT EOL
0967 4C1608 272        ZMOUT JMP GETCHR      ;BACK TO MAINLINE
096A 2010FC 273        ZBEG JSR BACKSP      ;BACKSPACE
096D CA 274           DEX                  ;DECREMENT POSITION IN LINE
096E D0FA 275          BNE ZBEG           ;DO IT AGAIN IF NOT AT LINE START
0970 8619 276          STX CHAR#           ;STORE CURSOR POSITION
0972 F0F3 277          BEQ ZMOUT           ;BACK TO MAINLINE
0974          278          ;
0974          279          ;CHARACTER SEARCH ROUTINE
0974          280          ;
0974 297F 281          CHRFDN AND #FIX        ;CONVERT NEG ASCII INPUT
0976 851B 282          STA STRT            ;STORE KEY CHARACTER
0978 A619 283          LDX CHAR#           ;GET PRESENT CURSOR POSITION
097A E8 284           CHRFLP INX            ;INCREMENT CURSOR POINTER
097B 20F4FB 285        JSR ADVANC          ;ADVANCE CURSOR
097E E419 286          CHRFL CPX CHAR#       ;AT OLD CURSOR POSITION?
0980 FOOD 287          BEQ CHFOUT         ;YES, CHARACTER NOT FOUND
0982 E41A 288          CPX EOL              ;END OF LINE?
0984 B00C 289          BCS SBEG            ;YES, START AGAIN AT LINE START
0986 BD0002 290        LDA BUFFER,X          ;GET CHARACTER AT THIS POSITION
0989 C51B 291          CMP STRT            ;SAME AS KEY?
098B D0ED 292          BNE CHRFLP          ;NO, TRY AGAIN
098D 8619 293          STX CHAR#           ;YES, STORE CURSOR POSITION
098F 4C1608 294        CHFOUT JMP GETCHR      ;BACK TO MAINLINE
0992 2010FC 295        SBEG JSR BACKSP      ;BACKSPACE
0995 CA 296           DEX                  ;BEGINNING OF LINE?
0996 D0FA 297          BNE SBEG            ;NO, BACKSPACE AGAIN
0998 F0E4 298          BEQ CHRFL          ;YES, CONTINUE SEARCH

```

```

099A      299      ;
099A      300      ;ZAP (DELETE TO END OF LINE) ROUTINE
099A      301      ;
099A A619      302      ZAP      LDX CHAR#          ;GET CURSOR POSITION
099C A9A0      303      LDA #BLANK      ;LOAD ACC. WITH SPACE CHAR
099E 204508    304      ZAPLP     JSR STRPNT     ;STORE AND PRINT IT
09A1 E8        305      INX          ;NEXT POSITION
09A2 E41A      306      CPX EOL      ;END OF LINE?
09A4 90F8      307      BCC ZAPLP     ;NO, DO IT AGAIN
09A6 20E408    308      JSR RESTOR     ;YES, RESTORE CURSOR
09A9 4C1608    309      JMP GETCHR     ;BACK TO MAINLINE
09AC      310      ;
09AC      311      ;DISK INPUT ROUTINE
09AC      312      ;
09AC A2FF      313      DISKIN LDX #ZERO-$1      ;INITIATE THE
09AE E8        314      DISKLI INX          ;CHAR# POINTER
09AF 200CFD    315      JSR KEYIN      ;GET A CHARACTER
09B2 9D0002    316      STA BUFFER,X     ;STORE IN BUFFER
09B5 C98D      317      CMP #CR        ;CARRIAGE RETURN?
09B7 D0F5      318      BNE DISKL1     ;NO, GET ANOTHER CHARACTER
09B9 861A      319      STX EOL      ;YES, STORE CHARACTER COUNT
09BB E8        320      INX          ;INIT FOR ASCII CONVERSION
09BC BDFF01    321      DISKL2 LDA BUFFER-$1,X     ;GET BUFFER CHARACTER
09BF 297F      322      AND #FIX      ;CONVERT FOR APPLESOF7
09C1 9DFF01    323      STA BUFFER-$1,X     ;PUT IT BACK
09C4 CA        324      DEX          ;COUNT BACK TO ZERO
09C5 D0F5      325      BNE DISKL2     ;LOOP IF NOT FINISHED
09C7 A61A      326      LDX EOL      ;CHAR COUNT IN X REG.
09C9 60        327      RTS          ;EXIT TO CALLER
          328      END

```

```

0800      1 ;*****
0800      2 ;*
0800      3 ;*   INTERFACE CODE   *
0800      4 ;*   FP - GETLN   *
0800      5 ;*
0800      6 ;*   BY
0800      7 ;*
0800      8 ;*   WES HUNTRESS
0800      9 ;*   SIERRA MADRE, CA *
0800     10 ;*
0800     11 ;*   COPYRIGHT (C) 1982 *
0800     12 ;*   MICRO INK, INC.  *
0800     13 ;*CHELMSFORD, MA 01824*
0800     14 ;* ALL RIGHTS RESERVED*
0800     15 ;*
0800     16 ;*****
0800     17 ;
0800     18 ;EQUATES: CONSTANTS & ZERO PAGE
0800     19 ;
0800     20 CURS   EPZ $19
0800     21 ZERO   EPZ $00
0800     22 BLANK  EPZ $A0
0800     23 LENLOC EPZ $02
0800     24 STADRL EPZ $08
0800     25 STADRH EPZ $09
0800     26 STRLEN EPZ $1A
0800     27 VARPTR EPZ $69
0800     28 ;
0800     29 ;EQUATES: BUFFER & ADDRESSES
0800     30 ;
0800     31 BUFFER EQU $0200
0800     32 GETLN  EQU $0800
0800     33 EENTRY EQU $0810
0800     34 STRPNT EQU $0845
0800     35 DISKIN EQU $09AC
0800     36 BACKSP EQU $FC10
0800     37 RETURN EQU $FC62
0800     38 ;
0300     39          ORG $0300
0300     40          OBJ $0800
0300     41 ;
0300     42 ;PRINT X$ SUBROUTINE
0300     43 ;
0300 A002     44 PSCRN  LDY #LENLOC
0302 B169     45          LDA (VARPTR),Y      ;GET X$ STRING LENGTH
0304 851A     46          STA STRLEN          ;STORE STRING LENGTH PTR
0306 A900     47          LDA #S00
0308 C51A     48          CMP STRLEN          ;LEN=0 MEANS JUST A CARRIAGE RETURN

030A F019     49          BEQ PSCRNX          ;SKIP IF JUST A CARRIAGE RETURN
030C C8       50          INY
030D B169     51          LDA (VARPTR),Y      ;GET X$ ADDR LOW BYTE
030F 8508     52          STA STADRL          ;STORE IN X$ ADDR PTR LOW
0311 C8       53          INY
0312 B169     54          LDA (VARPTR),Y      ;GET X$ ADDR HI BYTE
0314 8509     55          STA STADRH          ;STORE IN X$ ADDR PTR HI
0316 A000     56          LDY #ZERO          ;INITIATE THE
0318 A200     57          LDX #ZERO          ; COUNTERS
031A B108     58 PNTLP   LDA (STADRL),Y      ;GET MID$(X$,Y,1)
031C 204508   59          JSR STRPNT          ;STORE & PRINT
031F E8       60          INX          ;INCREMENT
0320 C8       61          INY          ; COUNTERS
0321 C41A     62          CPY STRLEN          ;END OF STRING?
0323 90F5     63          BCC PNTLP          ;NO, GET ANOTHER CHAR
0325 60       64 PSCRNX  RTS          ;EXIT TO CALLER
0326         65 ;
0326         66 ;PRINT X$ TO SCREEN
0326         67 ;
0326         68 PRINT   JSR PSCRN          ;PRINT X$
0329 2062FC   69          JSR RETURN          ;DO A CARRIAGE RETURN
032C 60       70          RTS          ;EXIT TO CALLER
032D         71 ;
032D         72 ;EDIT X$
032D         73 ;
032D 200003   74 EDIT    JSR PSCRN          ;PRINT X$

```

```

0330 A9A0      75          LDA #BLANK                ;PUT SPACE CHAR
0332 9D0002   76 EDLP1  STA BUFFER,X          ; INTO REMAINING
0335 E8        77          INX                    ; BUFFER SPACE
0336 DOFA     78          BNE EDLP1
0338 2010FC   79 EDLP2  JSR BACKSP              ;RESTORE CURSOR
033B 88       80          DEY                    ; TO LINE START
033C DOFA     81          BNE EDLP2
033E A200     82          LDX #ZERO              ;STORE CURSOR
0340 8619     83          STX CURS              ; POSITION
0342 201008   84          JSR ENTRY              ;GETLN EDIT ENTRY
0345 4C4B03   85          JMP TOX$              ;PUT IN X$
0348          86          ;
0348          87          ;X$ KEYBOARD INPUT
0348          88          ;
0348 200008   89 KYBIN  JSR GETLN                ;GET A LINE
034B A002     90 TOX$  LDY #LENLOC            ;TRANSFER STRING
034D 8A       91          TXA                    ; LENGTH FROM ACC.
034E 9169     92          STA (VARPTR),Y          ; TO X$
0350 C8       93          INY
0351 A900     94          LDA #ZERO              ;STORE
0353 9169     95          STA (VARPTR),Y          ; KEYBOARD
0355 C8       96          INY                    ; BUFFER
0356 A902     97          LDA #LENLOC            ; ADDRESS
0358 9169     98          STA (VARPTR),Y          ; INTO X$
035A 60       99          RTS                    ;EXIT TO CALLER
035B          100         ;
035B          101         ;X$ DOS INPUT
035B          102         ;
035B 20AC09   103 DOSIN JSR DISKIN              ;GETLN DOS INPUT ENTRY
035E 4C4B03   104          JMP TOX$              ;PUT INPUT IN X$
105          105         END

```

Trick DOS

by Sanford M. Mossberg

Here are a few techniques to help you get more power from Apple DOS.

On booting a disk, the DOS command table (DCT) comes to reside at RAM locations \$A884-\$A908 (decimal 43140-43272). The last letter of each of the 28 DOS commands is represented by a negative ASCII character which signals the end of the command. Other letters or numerals are written in positive ASCII code. A zero marks the end of the DCT. Armed with these simple facts, we can trick DOS 3.2 or 3.3 into obeying our whims and desires.

Listing 1 provides code for TRICK DOS. Following initialization (lines 2000-2060) and optional instructions (lines 2500-2670), a menu is presented (lines 600-710), each item of which is analyzed:

1. *Display Current DOS Command Table:* The heart of the entire program is found in the subroutine at lines 100-180. The starting location (START) of the table never changes. Lines 120-130 search successive memory locations in the DCT until a zero byte is found. The end address of the table, not including the zero byte, is assigned to the variable FIN. Line 140 initializes the array DOS\$(*,*), the contents of which are noted in line 102. Lines 150-180 PEEK DCT locations, fill the two-dimensional matrix and create a string (DOS\$) which contains every character in the DCT. Subsequently, the array variables will be used to format screen display (lines 860-880 and 1060-1070), and the string variable will be manipulated to alter the command table by POKEing data into RAM. The displayed DCT may be listed to a printer (see figure 1).

2. *Change DOS Command Table:* The program block starting at line 1000 first outputs current commands by utilizing the routine described earlier. The command to be changed (OC\$) is requested in line 1080. Since keyboard input is in positive ASCII code, the high bit of the final letter is turned on (line 1090). The validity of the command is checked in line 1100 and variable PT marks the position of the command in the array. An invalid command triggers an error message

(line 1110) and returns the user to the prior input request. The replacement command (NC\$) is solicited in line 1130 and negative ASCII conversion occurs in line 1140. The subroutine at lines 400-500 rearranges the DCT. Commands preceding and following the changed command are contained in T1\$ and T3\$, respectively; the new command is placed in T2\$. In line 460, DOS\$ is recreated by concatenation of the above-noted strings. Lines 470-500 POKE the new command table into memory. An incidental, but important, feature of this entire section, is the effective error trapping (lines 1080, 1110, 1120, 1130, 1170, 1180, 1210 and 1240) which prevents potential crashing of the program and assures professionally formatted screen display.

Figure 1: Current DOS Commands and Addresses

DEC	HEX	DEC	HEX		
43140	A884	INIT	43206	A8C6	APPEND
43144	A888	LOAD	43212	A8CC	RENAME
43148	A88C	SAVE	43218	A8D2	CATALOG
43152	A890	RUN	43225	A8D9	MON
43155	A893	CHAIN	43228	A8DC	NOMON
43160	A898	DELETE	43233	A8E1	PR#
43166	A89E	LOCK	43236	A8E4	IN#
43170	A8A2	UNLOCK	43239	A8E7	MAXFILES
43176	A8A8	CLOSE	43247	A8EF	FP
43181	A8AD	READ	43249	A8F1	INT
43185	A8B1	EXEC	43252	A8F4	BSAVE
43189	A8B5	WRITE	43257	A8F9	BLOAD
43194	A8BA	POSITION	43262	A8FE	BRUN
43202	A8C2	OPEN	43266	A902	VERIFY

3. *Restore Normal DOS Command Table and*

4. *Try these commands:* Data statements in lines 2100-2110 contain ASCII code for the normal DCT. Line 1330 reads the data into the variable NDOS\$. A sample table which I have found useful is coded in lines 2120-2130. Line 1340 produces MYDOS\$. Lines 1380-1390 replace the resident DCT with either of these strings, thus restructuring the entire command table rapidly.

5. *Exit Program:* At program termination all text and graphics modes should be normalized. Line 1510 accomplishes this by successively turning off hi-res, turning on text page one, clearing the keyboard strobe and setting a full text window. Although TRICK DOS does not require these steps, the habit is a good one to cultivate. After the program ends, the new command table will remain viable in RAM until rebooting occurs or power is discontinued. If you prefer, the new DCT can be preserved permanently by initializing a disk.

Knowing that DOS intercepts and reviews all commands before the Applesoft interpreter can process the command, several admonitions are appropriate. Each newly created DOS command should have a character set that does not duplicate the first letters of any Applesoft BASIC command. To better understand this pitfall, imagine that we have changed "LOAD" to "L" and "RENAME" to "RE". Now, if we type "LIST" or "LEFT\$", DOS understands this to mean LOAD (L=LOAD) the file "IST" or "EFT\$", and the "FILE NOT FOUND" error message is returned. Typing "REM" would produce the same error message as DOS attempted to RENAME (RE = RENAME) the nonexistent file "M." So far this is annoying but not harmful.

Consider the results from changing "INIT" to "I." Any Applesoft command beginning with an "I" would promptly start initializing the disk. This would be catastrophic and must be avoided! For the reasons cited above, I advise you to peruse a list of Applesoft BASIC commands before modifying a DOS command. Changing "LOAD" to "LD", "RENAME" to "RNM" and "INIT" to "I*" would have avoided the chaos. Choice #4 from the menu will create a table of "safe" commands that I have found to be functional.

When you begin using a newly created DCT, mistakes will be inevitable and error messages will proliferate. The DCT commands "LOAD" and "SAVE" are special in that they also exist as Applesoft commands to a cassette recorder. If either is used erroneously, the system will hang. Only by pressing "RESET" can you recover. If you do not have autostart ROM, altering these two commands may be more of a nuisance than an aid.

Experiment freely and enjoy your newfound power over DOS.

```

1  REM *****
2  REM *
3  REM *      TRICK DOS      *
4  REM *      SANDY MOSSBERG *
5  REM *
6  REM *      COPYRIGHT (C) 1982 *
7  REM *      MICRO INK, INC. *
8  REM *      CHELMSFORD, MA 01824*
9  REM *      ALL RIGHT RESERVED *
10 REM *
11 REM *****
20 TEXT : CALL - 936: POKE - 16298,0: POKE - 16300,0: POKE - 16368,0

30 GOSUB 2010: GOSUB 3010: GOSUB 2510: GOTO 610
100 REM

      PEEK COMMAND TABLE
      AND CREATE ARRAY

102 REM ARRAY DOS$(R1-28,C1-2)
      C1=COMMAND
      C2=START ADDR

104 REM DOS$=DOS COMMAND TABLE

106 REM DOS=ADDR COMMAND TABLE

110 TM = START
120 IF PEEK (TM) = 0 THEN FIN = TM - 1: GOTO 140: REM FIND END OF TABL
      E
130 TM = TM + 1: GOTO 120
140 I = 1: FOR J = 1 TO 29: FOR K = 1 TO 2:DOS$(J,K) = "": NEXT K,J:DOS$(
      1,2) = STR$(START):DOS$ = "": REM INITIALIZE
150 FOR DOS = START TO FIN
160 IF ASC ( CHR$( PEEK (DOS))) > 127 THEN DOS$(I,1) = DOS$(I,1) + CHR$(
      PEEK (DOS)):DOS$ = DOS$ + CHR$( PEEK (DOS)):DOS$(I+1,2) = STR$(
      DOS + 1):I = I + 1: GOTO 180: REM IF 41 BYTE INCR I
170 DOS$(I,1) = DOS$(I,1) + CHR$( PEEK (DOS)):DOS$ = DOS$ + CHR$( PEEK
      (DOS))
180 NEXT DOS: RETURN
300 REM

      DEC --> HEX

310 HD% = DOS / 256:NBR = HD%: GOSUB 340:HB$ = HEX$(
320 LD% = FN MOD(DOS):NBR = LD%: GOSUB 340:LB$ = HEX$(
330 HEX$ = HB$ + LB$: RETURN
340 H% = NBR / 16 + 1:L% = NBR / 16:L = L% * 16:L% = NBR - L + 1
350 HEX$ = MID$(H$,H%,1) + MID$(H$,L%,1): RETURN
400 REM

      REORGANIZE
      COMMAND TABLE

410 IF PT = 1 THEN T1$ = "": GOTO 430
420 T1$ = LEFT$(DOS$, VAL (DOS$(PT,2)) - START)
430 FOR I = 1 TO LEN (NC$):T2$ = T2$ + MID$(NC$,I,1): NEXT
440 IF PT = 28 THEN T3$ = "": GOTO 460
450 T3$ = RIGHT$(DOS$,FIN + 1 - VAL (DOS$(PT + 1,2)))
460 DOS$ = T1$ + T2$ + T3$:T2$ = ""
470 DOS = START
480 FOR I = 1 TO LEN (DOS$): POKE DOS, ASC ( MID$(DOS$,I,1)):DOS = DOS
      + 1: NEXT
490 FIN = FIN + LEN (NC$) - LEN (OC$)
500 POKE FIN + 1,0: RETURN
600 REM

      MENU

610 HOME :TT$ = "=====": GOSUB 3110
620 TT$ = "TRICK DOS MENU": GOSUB 3110
630 TT$ = "=====": GOSUB 3110
640 VTAB 6: PRINT "1.DISPLAY CURRENT DOS COMMAND TABLE.": PRINT
650 PRINT "2.CHANGE DOS COMMAND TABLE.": PRINT
660 PRINT "3.RESTORE NORMAL DOS COMMAND TABLE.": PRINT

```

```

670 PRINT "4.TRY SANDY'S COMMANDS.": PRINT
680 PRINT "5.EXIT PROGRAM.": PRINT : PRINT
690 VTAB 17: CALL - 958: PRINT " WHICH CHOICE? ";: GET I$: PRINT I$:
CH = VAL (I$)
700 IF CH < 1 OR CH > 5 OR I$ = "" THEN 690
710 ON CH GOTO 800,1000,1300,1300,1500
800 REM

```

DISPLAY CURRENT TABLE

```

810 HOME :TT$ = "=====": GOSUB 3110
820 TT$ = "CURRENT DOS COMMANDS & ADDRESSES": GOSUB 3110
830 TT$ = "=====": GOSUB 3110
840 IF NOT FF THEN VTAB 8: INVERSE :TT$ = " READING DOS COMMAND TABLE
": GOSUB 3110: NORMAL
850 GOSUB 110: VTAB 4: CALL - 958
860 PRINT : HTAB 2: INVERSE : PRINT "DEC";: HTAB 8: PRINT "HEX";: HTAB 2
2: PRINT "DEC";: HTAB 28: PRINT "HEX": NORMAL : PRINT
870 FOR I = 1 TO 14
880 PRINT DOS$(I,2) " ";DOS = VAL (DOS$(I,2)): GOSUB 310: PRINT HEX$ " "
DOS$(I,1);: HTAB 21: PRINT DOS$((I + 14),2) " ";DOS = VAL (DOS$((I +
14),2)): GOSUB 310: PRINT HEX$ " "DOS$((I + 14),1): NEXT
890 IF FF THEN FOR I = 1 TO 5: PRINT : NEXT : RETURN
900 VTAB 22: PRINT "LIST TABLE TO PRINTER (Y/N) ? ";: GET I$
910 IF I$ = "Y" THEN FF = 1: HTAB 1: CALL - 998: CALL - 958: PRINT B$:
INVERSE : PRINT " TURN PRINTER ON AND PRESS ANY KEY ": PRINT : HTAB
10: PRINT " EXPECT A PAUSE ";: GET I$: PRINT : NORMAL : PRINT D$;DOS
$(20,1);1: GOSUB 810:FF = 0: PRINT D$;DOS$(20,1);0: GOTO 610
920 IF I$ = "N" THEN 610
930 HTAB 1: GOTO 900
1000 REM

```

CHANGE TABLE

```

1010 HOME :TT$ = "=====": GOSUB 3110
1020 TT$ = "CHANGE COMMANDS": GOSUB 3110
1030 TT$ = "=====": GOSUB 3110
1040 VTAB 4: CALL - 958: VTAB 8: INVERSE :TT$ = " READING DOS COMMAND T
ABLE ": GOSUB 3110: NORMAL
1050 GOSUB 110: VTAB 5: CALL - 958
1060 FOR I = 1 TO 7
1070 PRINT DOS$(I,1);: HTAB 10: PRINT DOS$((I + 7),1);: HTAB 20: PRINT D
OS$((I + 14),1);: HTAB 30: PRINT DOS$((I + 21),1): NEXT
1080 VTAB 14: CALL - 958: INPUT "TYPE COMMAND TO BE CHANGED: ";OC$: IF
OC$ = "" THEN 1180
1090 OC$ = MID$(OC$,1, LEN (OC$) - 1) + CHR$ ( ASC ( RIGHT$(OC$,1)) +
128): REM TURN HI BIT ON IN LAST LETTER OF COMMAND
1100 FOR I = 1 TO 28: IF OC$ = DOS$(I,1) THEN PT = I: GOTO 1130: REM PT=
POINTER TO POSITION OF COMMAND IN ARRAY
1110 IF I = 28 THEN PRINT B$: VTAB 16: INVERSE : PRINT " NOT A VALID CU
RRENT COMMAND ": NORMAL : FOR J = 1 TO 3000: NEXT : GOTO 1080
1120 NEXT I
1130 VTAB 16: CALL - 958: INPUT "TYPE NEW COMMAND: ";NC$: IF NC$ = "" THEN
1130
1140 NC$ = MID$(NC$,1, LEN (NC$) - 1) + CHR$ ( ASC ( RIGHT$(NC$,1)) +
128): REM TURN HI BIT ON IN LAST LETTER OF COMMAND
1150 PRINT B$: VTAB 18: HTAB 3: PRINT "CONFIRM (Y/N) ? ";: GET I$: PRINT
I$
1160 IF I$ = "Y" THEN VTAB 20: INVERSE : PRINT " WRITING COMMAND TABLE
": GOSUB 410: VTAB 18: HTAB 1: CALL - 958: PRINT " CHANGE COMPLETED
": NORMAL : GOTO 1220
1170 IF I$ < > "N" THEN VTAB 18: CALL - 958: GOTO 1150
1180 VTAB 18: CALL - 958: PRINT : PRINT "RETURN TO MENU OR TRY AGAIN (M
/A) ? ";: GET I$: PRINT I$
1190 IF I$ = "A" THEN GOTO 1080
1200 IF I$ = "M" THEN 610
1210 GOTO 1180
1220 VTAB 20: CALL - 958: PRINT "ANOTHER CHANGE (Y/N) ? ";: GET I$: PRINT
I$: IF I$ = "Y" THEN 1040
1230 IF I$ = "N" THEN 610
1240 GOTO 1220
1300 REM

```

RESTORE NORMAL TABLE OR
INSTALL SANDY'S TABLE

```

1310 VTAB 20: INVERSE : PRINT " WRITING COMMAND TABLE ";
1320 NDOSS$ = "":MYDOSS$ = ""
1330 FOR I = 1 TO 132: READ D:NDOSS$ = NDOSS$ + CHR$( D): NEXT
1340 FOR I = 1 TO 67: READ D:MYDOSS$ = MYDOSS$ + CHR$( D): NEXT : RESTORE

1350 DOS = START
1360 IF CH = 3 THEN TMS$ = NDOSS$:TT$ = " NORMAL DOS COMMAND TABLE REESTAB
LISHED ":FIN = START + LEN (NDOSS$) - 1
1370 IF CH = 4 THEN TMS$ = MYDOSS$:TT$ = " SANDY'S COMMAND TABLE INSTALLED
":FIN = START + LEN (MYDOSS$) - 1
1380 FOR I = 1 TO LEN (TMS$): POKE DOS, ASC ( MID$( TMS,I,1)):DOS = DOS +
1: NEXT
1390 POKE FIN + 1,0
1400 HTAB 1: PRINT TT$: NORMAL : GOSUB 3210: HTAB 1: GOTO 690
1500 REM

        END PROGRAM

1510 POKE - 16298,0: POKE - 16300,0: POKE - 16368,0: TEXT : HOME
1520 VTAB 10: INVERSE :TT$ = " END OF TRICK DOS PROGRAM ": GOSUB 3110: NORMA

1530 VTAB 15: PRINT " INITIALIZING A DISK BEFORE REBOOTING": PRINT "WILL
PRESERVE THE CURRENT DOS COMMANDS"
1540 VTAB 22: END
2000 REM

        INITIALIZE

2010 DIM DOS$(30,2)
2020 D$ = CHR$( 4):B$ = CHR$( 7):SS$ = "                ": REM 21
SPACES
2030 H$ = "0123456789ABCDEF"
2040 DEF FN MOD(X) = X - INT ( X / 256) * 256: REM SIMULATE MOD FUNCTIO
N
2050 START = 43140: REM START OF TABLE
2060 RETURN
2100 DATA 73,78,73,212,76,79,65,196,83,65,86,197,82,85,206,67,72,65,73,2
06,68,69,76,69,84,197,76,79,67,203,85,78,76,79,67,203,67,76,79,83,19
7,82,69,65,196,69,88,69,195,87,82,73,84,197,80,79,83,73,84,73,79,206
,79,80,69,206,65,80,80,69,78,196
2110 DATA 82,69,78,65,77,197,67,65,84,65,76,79,199,77,79,206,78,79,77,79
,206,80,82,163,73,78,163,77,65,88,70,73,76,69,211,70,208,73,78,212,6
6,83,65,86,197,66,76,79,65,196,66,82,85,206,86,69,82,73,70,217: REM
NORMAL TABLE
2120 DATA 73,170,76,196,83,214,82,85,206,67,72,206,68,204,76,203,85,76,2
03,67,211,82,196,69,88,195,87,210,80,83,206,79,208,65,208,82,69,206,
67,65,212,77,206,78,77,206,80,163,73,163,77,65,216,70,208,73,78,212,
66,211,66,204,66,210,86,69,210
2130 DATA 77,206,78,77,206,80,163,73,163,77,65,216,70,208,73,78,212,66,2
11,66,204,66,210,86,69,210: REM
SANDY'S TABLE
2500 REM

        INSTRUCTIONS

2510 HOME :TT$ = "===== ": GOSUB 3110
2520 TT$ = "INSTRUCTIONS": GOSUB 3110
2530 TT$ = "===== ": GOSUB 3110
2540 VTAB 7: CALL - 958: PRINT "DO YOU WANT INSTRUCTIONS (Y/N) ? ": GET
I$: PRINT I$: IF I$ = "N" THEN RETURN
2550 IF I$ < > "Y" THEN 2540
2560 POKE 34,4: VTAB 5: CALL - 958
2570 PRINT "1.THE DOS COMMAND TABLE RESIDES AT RAM": PRINT " LOCATIONS
$A884 TO $A908 (DEC 43140": PRINT " TO 43272).": PRINT
2580 PRINT "2.EACH COMMAND IS REPRESENTED BY ASCII": PRINT " CHARACTER
CODES. ONLY THE LAST LETTER": PRINT " OF A COMMAND HAS THE HIGH BIT
ON SO": PRINT " THAT DOS CAN RECOGNIZE THE END OF THE"
2590 PRINT " COMMAND. NOTE THE EXAMPLES BELOW:": PRINT " PRINT " L
OAD = 4C 4F 41 C4": PRINT " INIT = 49 4E 49 D4": PRINT " R
UN = 52 55 CE": PRINT : PRINT
2600 PRINT "3.ZERO MARKS THE END OF THE TABLE."
2610 GOSUB 3210: HOME
2620 PRINT "4.THIS PROGRAM WILL ENABLE YOU TO ALTER": PRINT " THE COMMA
ND TABLE. YOU MAY DESIRE TO": PRINT " CHANGE 'CATALOG' TO ": INVERSE
: PRINT "CAT": NORMAL : PRINT " OR 'SAVE' TO ": PRINT " ": INVERSE
: PRINT "SV": NORMAL

```

```

2630 PRINT ". BE SURE THAT YOUR NEW DOS COMMAND": PRINT " DOES NOT DUPL
ICATE THE FIRST PART OF": PRINT " AN APPLESOFT BASIC COMMAND, OTHER
WISE": PRINT " UNUSUAL EVENTS MAY OCCUR. EXPERIMENT!"
2640 PRINT " TIREDNESS OR SILLINESS MAY RESULT IN": PRINT " WEIRD SYMB
OLS!!!": PRINT
2650 PRINT "5.THESE MODIFICATIONS WILL TRIGGER A": PRINT " SYNTAX ERROR
IF A DIRECT OR DEFERRED": PRINT " COMMAND UTILIZES 'NORMAL' TERMIN
OLOGY."
2660 PRINT "6.": INVERSE : PRINT "TRICK DOS": NORMAL : PRINT " IS MENU
-DRIVEN AND SELF-": PRINT " PROMPTING. HAVE FUN!!!"
2670 POKE 34,0: GOSUB 3210: RETURN
3000 REM

```

TITLE PAGE

```

3005 REM SF APPLE CORE FORMAT

```

```

3010 INVERSE : VTAB 4
3020 TT$ = SS$: GOSUB 3110: GOSUB 3110
3030 TT$ = " TRICK DOS ": GOSUB 3110
3040 TT$ = SS$: GOSUB 3110: GOSUB 3110
3050 TT$ = " BY SANDY MOSSBERG ": GOSUB 3110
3060 TT$ = SS$: GOSUB 3110: GOSUB 3110: NORMAL
3070 VTAB 16:TT$ = "CUSTOMIZE YOUR SET OF DOS COMMANDS!": GOSUB 3110
3080 GOSUB 3210: RETURN
3100 REM

```

PRINT CENTER

```

3110 WIDTH = 20 - ( LEN (TT$) / 2): IF WIDTH < = 0 THEN PRINT TT$: RETURN
3120 HTAB WIDTH: PRINT TT$: RETURN
3200 REM

```

CONTINUE/END

```

3210 VTAB 23: HTAB 12: PRINT "[ESC] TO END"
3220 VTAB 24: PRINT TAB( 8);"[SPACE] TO CONTINUE ";
3230 PRINT "[ ]": HTAB 29: GET ZZ$: IF ZZ$ = CHR$ (27) OR ZZ$ = CHR$
(3) THEN TEXT : HOME : GOTO 1510
3240 IF ZZ$ = CHR$ (32) THEN RETURN
3250 CALL - 868: CALL - 1008: GOTO 3230: REM

```

LACRAB

by N.R. McBurney

This utility produces a logically formatted and aesthetically pleasing listing of Applesoft programs, as well as a cross-reference table of their variables. These two functions not only yield a more professional looking documentation, but also make the task of program debugging and maintenance significantly easier.

Introduction

The following is an example of the screen output produced by the LIST command:

```
2400 IF BYTE = C1 THEN RE = 1:KM = KM + 5: REM COMMENT
2410 FOR I = 1 TO 255:BYTE = PEEK (LOC):LOC = LOC + 1: IF BYTE = 0 THEN
    RE = 0:LOC = LOC + 2: GOTO 2340
2420 IF RE THEN KM = KM + 1
2430 NEXT
```

It isn't very easy to read. In fact, it is rather confusing. Take a second to examine the program listing at the end of this article, specifically at the listing for lines 2400-2430. I hope that you'll agree that the format of this second listing is considerably easier to read and more informative than the above example.

LACRAB stands for List And Cross Reference Applesoft BASIC. It has capabilities that make program debugging and documentation significantly easier. First, LACRAB prints only one statement per line and indents lines to suggest subordinate relationships. This feature alone greatly improves program readability. Second, LACRAB puts REM statements in boxes so that they stand out clearly. In-line REM statements (i.e., REM statements tacked on to another statement with a colon) are tabbed out to separate them from executable code and make them easy to see. Third, user-provided titling is accommodated along with automatic pagination for professional-quality documentation. Fourth, LACRAB

generates a cross-reference table that identifies each line in which a variable appears. That table also flags undefined variables, equivalent variables, and variables that appear on only one line. Finally, the program length, in bytes, is printed out along with an approximation of the amount of RAM occupied by REM statements.

To be able to perform the above tasks on a program in RAM, we need to know how the program is represented in RAM and where it begins and ends. A BASIC statement in RAM starts with two bytes that point to the next BASIC statement. This is followed by two bytes containing the line number in numeric integer format, followed by the BASIC statement proper. Finally, a zero byte indicates the end of the BASIC statement.

Within the BASIC statement, bytes with values less than 128 represent ASCII characters. Bytes with values greater than 127 represent tokens that the Applesoft interpreter has substituted for BASIC keywords (e.g., 186 for PRINT). These token values are described in Appendix F of the Applesoft BASIC manual. Appendix L of that same manual tells us that the address of the start of the program is contained in decimal locations 103-104 and the end of the program in locations 175-176. Armed with this knowledge, one can write a program that examines the necessary memory locations byte by byte, builds up each line as a string, and outputs it to a printer. LACRAB is an elaboration of this basic scheme.

Program Operation

To run LACRAB, simply load the program to be listed and type EXEC LIST. The screen will clear and request heading information as below:

```
PROGRAM NAME?LISTER TEST CASE #1
DATE/TIME?AUGUST 11, 1980 8:50 PM
```

Once that information is provided the menu shown below will appear:

Figure 1: LACRAB Menu

```
SYSTEM MENU
FOR
PROGRAM TO:
```

```
LIST AND CROSS REFERENCE APPLESOFT BASIC
```

- 1) LISTING ONLY
- 2) CROSS REFERENCE ONLY
- 3) LISTING AND XREF

```
WHICH OPTION?
```

After you've selected one of the above print options, your program will be listed. LACRAB assumes that the printer interface board is in slot one. If a cross-reference was requested, a display similar to the one below will appear when the listing is complete:

Figure 2: LACRAB Cross-Reference Monitor Display

```

                                LACRAB
                                SYMBOL TABLE GENERATION MONITOR

LINE      CURRENT      OPERATING
NUMBER    SYMBOL        STATISTICS

1170      BLK
1170      LOC           CURR. LINE      1230
1170      LOC           LINES PROC.    23
1170      LOC           PROG. BYTES    10522
1180      LNE$         CURRENT BYTE    560
1180      LNE          % COMPLETE     5%
1180      B5           SYM TABLE LEN  11
1190      BYTE        LAST          SYMBOL:
1190      LOC                             C2
1190      LOC
1190      LOC
1210      BYTE
1210      C1
1220      COMMENTS
1230      BYTE
1230      C2

```

Frankly, there isn't any logical requirement for the above display. I provide it because the cross-reference portion of LACRAB can be time-consuming (approximately 12 minutes to cross-reference LACRAB) and it frustrates me to stare at a blank screen. Once the cross-reference is complete and has printed out, LACRAB terminates with the following display:

```

37 LINES PRINTED.
LISTING COMPLETE....

```

]

At that point the program you just listed will be available to you.

How it Works

The first executable statement in LACRAB (line #3440) transfers control to the initialization routine (lines 3440-3840). This routine and the menu display section (lines 3850-4260) are located at the end of the program to make the remainder of the program run faster. (As a general rule, infrequently executed code should always be placed at the end of a program.)

The variables CO\$, LINE\$ and DF% (dimensioned in line 3450) are used during the cross-reference to store variable names (CO\$), line numbers where the variable is referenced (LINE\$), and a flag to indicate that a variable has been defined (DF%). Each of these variables is dimensioned to 200 and hence limits the number of variables that LACRAB can cross-reference to 200 — a limit that I've yet to approach.

The variable CO\$ does double duty. In addition to holding variable names, it is used as temporary storage for consecutive REM statements while LACRAB is listing. Again, this limits LACRAB's capacity to 200 consecutive REM statements per program. I don't believe I've ever seen a BASIC program with 200 consecutive REM statements and don't believe this imposes much of a limitation.

In line 3620, the page width is assigned the value of 76 print positions. This value can be changed to adapt LACRAB to your particular printer configuration. The variable S6, defined in line 3790, sets the page length at 66 lines. The function PAGE, defined in line 3800, is simply a modulo function used in the output section to determine when to print page headings. The variable KOMMENT, set in line 3810, establishes the print position for 'in-line' REM statements. Again, at least in theory, you should be able to set this to any value compatible with your printer's capabilities and your own sense of esthetics.

After initialization and selection of output options, control is transferred to the program listing section (lines 1120-2040). Line numbers 1170 and 1180 pick up the line number of the next statement to be listed. At line 1190 LACRAB starts examining the program statement byte by byte. Lines 1200-1270 check for tokens that will require special formatting: REM (C1), colon (C2), THEN (C3), FOR (C4), and NEXT (C5). If the byte has none of these values, it is translated either into a character or a BASIC keyword and appended to the next line to be printed. This process occurs in lines 1290-1360.

If the byte is a REM token (i.e., byte = 178) that immediately follows a line number, control is transferred to lines 1370-1420. Here the REM statement is decoded and stored in the CO\$ array. The variable COMMENTS, used to keep track of how many consecutive REM statements have been processed, is incremented by one. LACRAB will continue to 'save' REM statements until the first non-REM statement is detected (line #1220). When that occurs, control is transferred to the routine in lines 1850-2040 where the comments are boxed and then output. Note that when LACRAB outputs REM statements the REM keyword is not printed. In the author's opinion, the output format of LACRAB makes it perfectly obvious which statements are and are not comment statements.

I have elected to take a contrary approach with implied GOTO statements. When LACRAB encounters a BASIC statement of the form

```
IF condition THEN line number
```

it prints out:

```
IF condition THEN GO TO line number
```

Note the space between GO and TO. LACRAB prints 'GO TO' instead of 'GOTO' to indicate that the 'GOTO' does not actually exist in the statement.

THEN tokens are processed in lines 1530-1580 and colons (:) are processed in lines 1450-1520. If the next byte following the colon is a REM token, lines 1460-1500 tabs the REM statement out to the print position specified by KOMMENT (currently 41). Since there may be some confusion if the REM keyword is omitted from in-line REM statements, LACRAB replaces the REM with a '!'.

The GOSUB 3240's sprinkled throughout the listing section of LACRAB transfer control to the line output routine (lines 3240-3310). If you make any changes to LACRAB (perhaps you're as opinionated as the author as to what constitutes esthetically pleasing program listings!), you should be careful to use this routine for output. The routine handles pagination, page numbering, and the 'folding' of lines where appropriate. It is this section of LACRAB that you would want to modify to make use, for example, of a printer's form feed feature or perhaps print out titles in an expanded print font. All LACRAB printer output should be handled by this routine.

The cross-reference portion of LACRAB begins at line 2060. Lines 2060-2260 display the headings for the screen display shown in figure 2.

Lines 2270-2311 involve a bit of trickery. What this code does, in effect, is to delete lines 1000-2310. The listing portion of LACRAB is no longer needed once the cross-reference is started. This results in faster execution of LACRAB's cross-reference procedure. This piece of bit-shuffling wizardry is accomplished by finding the address of where we currently are in the program (line #2290), skipping two lines (line #2310), and then resetting the start of program pointer to this new address (line #2311).

The main cross-reference loop begins at line 2340. At line 2350 the line number (LNE) is decoded. The rest of line 2350 and line 2360 update the cross-reference display shown in figure 2.

Lines 2370 through 2780 are a routine that decodes each variable as it is encountered. As each variable is decoded, that symbol and its associated line number are displayed at the bottom of the left-hand side of the display. At line 2710, the line number where the symbol is referenced is stored in the corresponding string array LINES\$. This is accomplished by appending the line number (stored as two bytes in the string). The line number of the reference to the first

variable (CO\$(1)) is stored in character positions 1 and 2 of LINE\$(1) in integer word format. The line number of the second reference to the same variable is stored in character positions 3 and 4, and so on.

There are several ways I could have handled the storage of line references. One can dimension matrices to handle the maximum number of references anticipated; one can write his own dynamic memory scheme; or one can take the easy way out and use strings, letting Apple worry about memory management. I opted for the latter solution.

Since a string can be, at most, 255 characters in length, no more than 127 references to a single variable are possible. More references will generate an error message at line 2750. In practice, I have never found this limit restrictive.

Once all of the program variables and their references have been decoded and stored in memory, they are sorted (in lines 2790-2830). When the sort begins, the flashing message "SORTING" is displayed on the screen. During the sort, every time an interchange occurs (line #2830), the Apple's speaker clicks. As before, I just like to be assured that something is occurring.

After the sort is complete, LACRAB starts printing the cross-reference table (lines 2880-3150). As it prints out each variable and its associated line references, it may prepend one of three symbols to the variable. If during the building of the cross-reference table LACRAB cannot find a variable definition, that variable is prepended with " →>" during printout. If the variable only occurs in one line, it is prepended with an asterisk (*) at line 2920. While this may not always indicate a problem, it generally points to a misspelled variable name. Finally, if a variable is equivalent to a previous variable, "***" is prepended to the variable name. Because Applesoft BASIC only recognizes the first two characters of a variable, SIGMA and SIGN would be flagged as equivalent by LACRAB.

At the end of the cross-reference, an explanation of the symbols described above is printed (lines 3160-3200) and lines 3210 and 3240 print out the program length and the amount of RAM taken up by REM statements. LACRAB's last activity is to reset the end-of-program and start-of-program pointers (lines 3380-3400) and return control to the user.

Bugs — Real and Imagined

I know of two bugs in LACRAB. First, if one uses numbers in exponential format (e.g., I = 1.0E16), LACRAB will pick up the exponential portion as a variable during the cross-reference. 'E16' in the previous example would be identified as a variable. The second bug occurs when a statement is attached to a 'DATA' statement with a colon (e.g., 10 DATA 25:I = 10). During the cross-reference, LACRAB simply skips to the end of the line when it detects either a 'DATA' or a 'REM' statement. Hence, in the above example, LACRAB would be unaware of the reference to 'I' in statement number 10. Since I never combine 'DATA' with other type of statements, and rarely use exponential notation, I've never incorporated the necessary code to resolve those deficiencies.

Conclusion

LACRAB was written on an Apple II Plus (floating point BASIC-in-ROM) with 48K RAM. With two minor changes LACRAB should work with RAM Applesoft BASIC. The first location to be examined by LACRAB should be changed in line 3760 from 2051 to 12291 (i.e., 3760 LOC = 12291). Line 3400 POKEs the hex value \$801 into locations 103-104. The value needs to be changed to \$3001 (i.e., 3400 POKE 103,1:POKE 104,48). Since I don't have RAM BASIC I've not tested these changes.

LACRAB takes up approximately 10.2K of RAM. Running it through a good optimizer such as Sensible Software's AOPT program will reduce that by about 35% to 6.6K, although it will not appreciably speed up processing.

```

=====
1000                                     +-----+
1010                                     | ***** |
1015                                     | *       |
1020                                     | *      APPLESOFT      * |
1030                                     | * BASIC PROGRAM LISTER * |
1040                                     | *      N. R. MCBURNEY  * |
1050                                     | *      COPYRIGHT (C) 1982 * |
1060                                     | *      MICRO INK, INC.  * |
1070                                     | * CHELMSFORD, MA 01824 * |
1080                                     | *      ALL RIGHTS RESERVED * |
1090                                     | *       * |
1095                                     | ***** |
                                     +-----+

1110 GOSUB 3440:                                     ! CALL INITIALIZATION ROUTINE
                                     +-----+
1120                                     | MAIN PROGRAM |
                                     +-----+

1140 IF NOT LST THEN
      GO TO 3320
1150 PR# 1
1160 IF LOC > = EOP THEN
      GO TO 3320
1170 LNE = PEEK(LOC) + BLK * PEEK(LOC + 1):
      LOC = LOC + 2
1180 LNE$ = RIGHT$(" " + STR$(LNE),B5):! CONVERT LINE NUMBER TO STRING
1190 BYTE = PEEK(LOC):
      LOC = LOC + 1

1200                                     +-----+
                                     | CHECK FOR KEY TOKENS |
                                     +-----+

1210 IF BYTE = C1 THEN
      GO TO 1380
1220 IF COMMENTS THEN
      GO TO 1850
1230 IF BYTE = C2 THEN
      GO TO 1450
1240 IF BYTE = C3 THEN
      GO TO 1540
1250 IF BYTE = C4 THEN
      GO TO 1600
1260 IF BYTE = C5 THEN
      GO TO 1750
1270 IF BYTE < C6 THEN
      GO TO 1310

1280                                     +-----+
                                     | BUILD UP THE LINE |
                                     +-----+

1290 TXT$ = TXT$ + TKNS(BYTE - A8):
      IF BYTE < 210 THEN
          TXT$ = TXT$ + " "
1300 GOTO 1190
1310 IF BYTE = 0 THEN
      GOSUB 3240:
      QUOTE = 0:

1320 TXT$ = TXT$ + CHR$(BYTE)
1330 IF BYTE < > 34 THEN
      GO TO 1190
1340 IF QUOTE = 0 THEN
      QUOTE = 1:
      GOTO 1190
1350 QUOTE = 0

=====
      LOC = LOC + 2:
      GOTO 1160
1320 TXT$ = TXT$ + CHR$(BYTE)
1330 IF BYTE < > 34 THEN
      GO TO 1190
1340 IF QUOTE = 0 THEN
      QUOTE = 1:
      GOTO 1190
1350 QUOTE = 0
=====

```

```

1360 GOTO 1190
1370                                     +-----+
                                     ! PROCESS COMMENTS !
                                     +-----+
1380 COMMENTS = COMMENTS + 1:
    COS(COMMENTS) = LNES + "1 "
1400 BYTE = PEEK(LOC):
    LOC = LOC + 1:
    IF BYTE = 0 THEN
        LOC = LOC + 2:
        GOTO 1160
1420 COS(COMMENTS) = COS(COMMENTS) + CHR$(BYTE):
    GOTO 1400
1440                                     +-----+
                                     ! PROCESS COLON !
                                     +-----+
1450 TXT$ = TXT$ + ":"
1460 IF PEEK(LOC) < > 178 THEN
    GO TO 1510:                                     ! CHECK FOR 'REM'
1470 J = LEN(TXT$) + SPACE + B5:
    RM = 1:
    IF J > KOMMENT THEN
        GO TO 1500
1480 FOR I = J TO KOMMENT
1490     TXT$ = TXT$ + " ":
    NEXT :
    QUOTE = 0
1500 TXT$ = TXT$ + "1 " :
    LOC = LOC + 1:
    GOTO 1190
1510 IF NOT QUOTE THEN
    GOSUB 3240
1520 GOTO 1190
1530                                     +-----+
                                     ! PROCESS 'THEN' !
                                     +-----+
1540 TXT$ = TXT$ + " THEN":
    THN = THN + 3:
    GOSUB 3240:
    SPACE = SPACE + 3:
    IF PEEK(LOC + 1) < A3 OR PEEK(LOC) > A4 THEN
        GO TO 1190
1570 TXT$ = "GO TO " :                                     ! ADD IMPLIED 'GO TO'
1580 GOTO 1190
1590                                     +-----+
                                     ! PROCESS 'FOR' !
                                     +-----+

```

LACRAB
04/05/82
PAGE - 3

```

=====
1600 TXT$ = TXT$ + "FOR "
1610 BYTE = PEEK(LOC):
    LOC = LOC + 1
1620 IF BYTE = 0 THEN
    GOSUB 3240:
    LOC = LOC + 2:
    GOTO 1710
1630 IF BYTE < > C2 THEN
    GO TO 1660
1640 IF PEEK(LOC) = C1 THEN
    NFR = 1:
    GOTO 1230
1650 TXT$ = TXT$ + " ":
    GOSUB 3240:
    GOTO 1710
1660 IF BYTE < A8 THEN
    GO TO 1690
1670 TXT$ = TXT$ + TKN$(BYTE - A8):
    IF BYTE < 210 THEN
        TXT$ = TXT$ + " "
1680 GOTO 1610
1690 TXT$ = TXT$ + CHR$(BYTE)

```

116 I/O Enhancements

```

1700 GOTO 1610
1710 SPACE = SPACE + 3
1720 IF BYTE = 0 THEN
      GO TO 1160
1730 GOTO 1190

1740                                     +-----+
      | PROCESS 'NEXT' |
      +-----+

1750 SPACE = SPACE - 3:
      TXT$ = TXT$ + "NEXT "
1770 BYTE = PEEK(LOC):
      LOC = LOC + 1:
      IF BYTE = 0 THEN
          GOSUB 3240:
          LOC = LOC + 2:
          GOTO 1160
1790 IF BYTE = C2 THEN
      TXT$ = TXT$ + " ":
      GOSUB 3240:
      GOTO 1190
1800 IF BYTE = A7 THEN
      TXT$ = TXT$ + ", ":
      SPACE = SPACE - 3:
      GOTO 1770
1810 IF BYTE > A8 THEN
      TXT$ = TXT$ + " " + TKN$(BYTE - A8):
      GOTO 1770
1820 TXT$ = TXT$ + CHR$(BYTE):
      GOTO 1770

1840                                     +-----+
      | PROCESS COMMENTS |
      +-----+

```

LACRAB
04/05/82
PAGE - 4

```

=====
1850 SSPACE = SPACE:
1860 LN = 0:
      SVE$ = LNE$
1870 FOR I = 1 TO COMMENTS:
1880   IF LEN(CO$(I)) > LN THEN
      LN = LEN(CO$(I))
1890 NEXT
1900 SPACE = (WIDTH - LN) / 2:
      IF SPACE < 1 THEN
          SPACE = 1:
1910 GOSUB 2000:
1920 FOR I = 1 TO COMMENTS
1930   LNE$ = LEFT$(CO$(I),B5):
1940   TXT$ = MID$(CO$(I),6)
1950   FOR J = LEN(CO$(I)) TO LN
1960     TXT$ = TXT$ + " ":
1970     NEXT :
1980     TXT$ = TXT$ + "!"
1990     GOSUB 3240:
2000 NEXT
2010 GOSUB 2000
2020 COMMENTS = 0:
2030 LNE$ = SVE$:
2040 SPACE = SSPACE:
2050 IF NOT CX THEN
      GO TO 1230
2060 GOTO 3340
2070 LNE$ = " "
2080 TXT$ = "+"
2090 FOR I = 1 TO LN - B5:
2100   TXT$ = TXT$ + "-":
2110 NEXT
2120 TXT$ = TXT$ + "+":
2130 GOSUB 3240
2140 RETURN

2050                                     +-----+
      | GENERATE STATUS DISPLAY |
      +-----+

```

```

2060 XREF = 0:
      PRINT CHR$(4)
2070 HOME :                               ! BEGIN STATUS DISPLAY
2080 PRINT TAB( 14);"*** LACRAB ***"
2090 PRINT TAB( 5);"SYMBOL TABLE GENERATION MONITOR"
2100 A$ = "-----";
      PRINT A$
2110 PRINT "LINE";TAB( 9);"CURRENT";TAB( 23);"OPERATING"
2120 PRINT "NUMBER SYMBOL";TAB( 23);"STATISTICS"
2130 PRINT LEFT$(A$,7);" ";LEFT$(A$,13);" ";LEFT$(A$,18)
2140 POKE 32,22:
      HTAB 23
2150 PRINT "CURR. LINE"
2160 PRINT "LINES PROC."
2170 L = EOP - 2049:
      SIZE = L:                               ! SAVE PROGRAM SIZE
2180 PRINT "PROG. BYTES ";RIGHT$(" " + STR$(L),5);

```

LACRAB
04/05/82
PAGE - 5

```

=====
2190 L = L * 0.0099:
      POKE 32,0:
      VTAB 12:
      HTAB 23
2200 PRINT "CURRENT BYTE"
2210 POKE 32,22:
      HTAB 23
2220 PRINT "% COMPLETE"
2230 PRINT "SYM TABLE LEN"
2240 PRINT "LAST SYMBOL:"
2250 POKE 34,7:
      POKE 32,0
2260 LOC = 8 * BLK + 3:
      GOTO 2290
                                     +-----+
2270                               ! SET START OF PROGRAM ADDRESS TO START !
2280                               ! OF CROSS REFERENCE (IE. SPEED UP PROGRAM) !
                                     +-----+
2290 START = PEEK(121) + BLK * PEEK(122):
      FOR I = 1 TO 3
2310   IF PEEK(START) < > 0 THEN
          START = START + 1:
          GOTO 2310
2311   START = START + 1:
      NEXT I
      POKE 103,PEEK(START):
      POKE 104,PEEK(START + 1)
                                     +-----+
2330                               ! CROSS REFERENCE !
                                     +-----+
2340 IF LOC > = EOP THEN
      GO TO 2790
2350 LNE = PEEK(LOC) + PEEK(LOC + 1) * BLK:
      SYMBOL = 0:
      NN = 0:
      RD = 0:
      VTAB 9:
      HTAB 35:
      PRINT RIGHT$(" " + STR$(LNE),B5);:
      KK = KK + 1:
      VTAB 10:
      HTAB 35:
      PRINT RIGHT$(" " + STR$(KK),B5);
2360 VTAB 12:
      HTAB 35:
      PRINT RIGHT$(" " + STR$(LOC - B6),B5);:
      VTAB 13:
      HTAB 35:
      PRINT RIGHT$(" " + STR$(INT((LOC - B6) / L)) + "%",B5);:
      LOC = LOC + 2
2370 BYTE = PEEK(LOC):
      LOC = LOC + 1

```

```

2380 IF BYTE = B1 OR BYTE = B2 OR BYTE = B3 THEN
      RD = 1:                                     ! READ, GET OR INPUT
2390 IF BYTE < > B4 AND BYTE < > C1 THEN

```

```

LACRAB
04/05/82
PAGE - 6

```

```

=====
      GO TO 2450:                                ! CHECK FOR 'DATA' & 'REM' TOKENS
2400 IF BYTE = C1 THEN
      RE = 1:
      KM = KM + 5:                                ! COMMENT
2410 FOR I = 1 TO 255:
      BYTE = PEEK(LOC):
      LOC = LOC + 1:
      IF BYTE = 0 THEN
        RE = 0:
        LOC = LOC + 2:
        GOTO 2340
2420 IF RE THEN
      KM = KM + 1
2430 NEXT
2450 IF BYTE < > C9 THEN
      GO TO 2500:                                ! CHECK FOR QOUTED LITERAL
2460 FOR I = 1 TO BLK:
      BYTE = PEEK(LOC):
      LOC = LOC + 1
2470 IF BYTE = C9 THEN
      GO TO 2550
2480 IF BYTE = 0 THEN
      GO TO 2500
2490 NEXT
2500 IF BYTE = 0 AND NOT WRD THEN
      LOC = LOC + 2:
      GOTO 2340
2510 IF (BYTE < A1 OR BYTE > A2) AND NOT (WRD AND BYTE > = A3 AND BYTE <
= A4) THEN
      GO TO 2530:                                ! NON-VARIABLE CHARACTER
2520 SYMBOL$ = SYMBOL$ + CHR$(BYTE):
      :
      WRD = 1:
      GOTO 2370
2530 IF NOT WRD THEN
      LP = 1:
      GOTO 2640
2540 IF BYTE = A5 OR BYTE = A6 THEN
      GO TO 2520:                                ! '$' OR '&'
2550 WRD = 0:
      POKE 33,22:
      IF SYMBOL$ < > "" THEN
        VTAB 24:
        HTAB 1:
        PRINT LNE;TAB( 9);SYMBOL$:
        IF NOT TEST THEN
          SYMBOL = 1
2560 POKE 33,39:
      IF KNT = 0 THEN
        GO TO 2600
2570 FOR I = 1 TO KNT
2580 IF SYMBOL$ = CO$(I) THEN
      GO TO 2630:                                ! NOT A NEW SYMBOL
2590 NEXT
2600 IF SYMBOL$ = "" THEN

```

```

LACRAB
04/05/82
PAGE - 7

```

```

=====
      GO TO 2770
2610 KNT = KNT + 1:
      I = KNT:
      IF KNT > 200 THEN
        PRINT "TOO MANY SYMBOLS FOR CROSS REFERENCE";CHR$(7):
        STOP

```

```

2620 VTAB 14:
      HTAB 36:
      PRINT RIGHT$(" " + STR$(KNT),4);:
      VTAB 16:
      HTAB 25:
      HTAB 25:
      VTAB 16:
      PRINT RIGHT$(" " + SYMBOL$,15):
      COS(KNT) = SYMBOLS
2630 SYMBOLS = "":
      IF SYMBOL AND NOT NN THEN
          NN = I
2640 IF SYMBOL AND (BYTE = C8 OR RD) THEN
      DF%(NN) = 1:
      SYMBOL = 0
2650 IF BYTE = C7 THEN
      TEST = 1:
      I BEGIN 'IF'
2660 IF BYTE = C2 THEN
      SYMBOL = 0:
      NN = 0:
      I 'COLON'
2670 IF BYTE = C3 THEN
      TEST = 0:
      NN = 0:
      SYMBOL = 0:
      I END 'IF'
2680 IF LP THEN
      LP = 0:
      GOTO 2370
2690 IF LEN(COS(I)) > MAX THEN
      MAX = LEN(COS(I))
2700 IF LEN(LINES(I)) > = 254 THEN
      GO TO 27450
2710 LINES(I) = LINES(I) + CHR$(LNE / BLK) + CHR$(LNE - INT(LNE / BLK) * BLK)
2730 GOTO 2770
2750 PRINT "TOO MANY REFERENCES TO ";COS(I);"." :
      PRINT "REFERENCES AFTER LINE #";LNE;" IGNORED." :
      GOTO 2770
2770 IF BYTE = 0 THEN
      LOC = LOC + 2:
      GOTO 2340
2780 GOTO 2370
2790
      +-----+
      ! SORT CROSS REFERENCE !
      +-----+
2800 FLASH :
      VTAB 20:
      HTAB 25:
      PRINT "SORTING":
      NORMAL

```

```

=====
2810 FOR L = KNT TO 2 STEP - 1:
      K = 1:
      C$ = LEFT$(COS(1),2) + RIGHT$(COS(1),1)
2820 FOR J = 2 TO L:
      B$ = LEFT$(COS(J),2) + RIGHT$(COS(J),1):
      IF B$ > C$ THEN
          K = J:
          C$ = B$
2830 NEXT :
      A$ = COS(L):
      COS(L) = COS(K):
      COS(K) = A$:
      A$ = LINES(L):
      LINES(L) = LINES(K):
      LINES(K) = A$:
      I = DF%(L):
      DF%(L) = DF%(K):
      DF%(K) = I:
      I = PEEK(- 16336):
NEXT

```

```

+-----+
2850      ! OUTPUT CROSS REFERENCE !
+-----+

2860 PR# 1:
      POKE 33,40:
      POKE 34,0:
      HOME :
      BYTE = 1:
      SPACE = 0:
      RM = 0:
      MAX = MAX + 2:
      MX = WIDTH - SPACE - MAX:
      LNE$ = " ":
      TXT$ = " ":
      GOSUB 3240:
      LNE$ = " ":
      TXT$ = "BEGIN CROSS REFERENCE.....":
      GOSUB 3240
2870 LNE$ = " ":
      TXT$ = " ":
      GOSUB 3240:
      SPACE = 1:
      OLD$ = " ":
      I = TRASH:
                                     ! UNDEFINED SYMBOL FOR TEST
                                     PURPOSES

2880 FOR I = 1 TO KNT
2890   IF COS(I) = " " THEN
      LNE$ = LEFT$( "
                                     ",MAX):
      GOTO 2980
      COS(I) = " " + COS(I)
2900   IF NOT DF&(I) THEN
      COS(I) = "->" + MID$(COS(I),3):
      GOTO 2930:
                                     ! UNDEFINED SYMBOL
2920   IF LEN(LINE$(I)) = 2 THEN
      COS(I) = " *" + MID$(COS(I),3):! SYMBOL ONLY OCCURS ON ONE LINE

                                     LACRAB
                                     04/05/82
                                     PAGE - 9
=====
2930   LNE$ = LEFT$(COS(I) + "
                                     ",MAX)
2940   IF MID$(COS(I),3,2) < > MID$(OLD$,3,2) THEN
      GO TO 2970:
                                     ! CHECK FOR DUPLICATE SYMBOLS
2950   A$ = RIGHT$(COS(I),1):
      IF A$ = "&" OR A$ = "$" THEN
      IF RIGHT$(OLD$,1) = A$ THEN
      LNE$ = "***" + MID$(LNE$,3)
2960   IF A$ > "&" AND RIGHT$(OLD$,1) > "&" THEN
      LNE$ = "***" + MID$(LNE$,3)
2970   IF COS(I) < > " " THEN
      OLD$ = COS(I)
2980   FOR J = 1 TO LEN(LINE$(I)) STEP 2:! DECODE LINE NUMBERS
3000     L = ASC(MID$(LINE$(I),J,1)) * BLK + ASC(MID$(LINE$(I),J + 1,1))
3010     IF L < > LORD THEN
      TXT$ = TXT$ + RIGHT$( "
                                     " + STR$(L),6)
3020     LORD = L:
      IF LEN(TXT$) > = 249 THEN
      LINE$(I) = MID$(LINE$(I),J + 2):
      COS(I) = " ":
      I = I - 1:
      GOTO 3040
3030   NEXT J
3040   LORD = 0
3050   IF LEN(TXT$) < MX THEN
      GO TO 3140:
                                     ! CHECK LINE LENGTH
3060   FOR J = 1 TO MX - 1:
      K = MX - J
3070     IF MID$(TXT$,K,1) = " " THEN
      GO TO 3090
3080   NEXT J
3090   K = K - 1:
      IF MID$(TXT$,K,1) = " " THEN
      GO TO 3090
3100   B$ = MID$(TXT$,K + 1)

```

```

3110  TXT$ = LEFT$(TXT$,K):
      GOSUB 3240:
      TXT$ = B$
3120  LNE$ = LEFT$("                ",MAX)
3130  GOTO 3050
3140  GOSUB 3240
3150  NEXT I
3160  LNE$ = " ":
      TXT$ = " ":
      GOSUB 3240:
      LNE$ = "NOTES:":
      GOSUB 3240
3170  LNE$ = " * INDICATES SYMBOL REFERENCED ONLY ONCE.":
      GOSUB 3240
3180  LNE$ = "*** INDICATES SYMBOL EQUIVALENT TO PREVIOUSLY DEFINED SYMBOL.":
      GOSUB 3240
3190  LNE$ = "-> INDICATES UNDEFINED SYMBOL.":
      GOSUB 3240
3200  LNE$ = " PROGRAM IS " + STR$(SIZE) + " BYTES LONG.":
      GOSUB 3240
3210  LNE$ = " COMMENTS ACCOUNT FOR APPROXIMATLY " + STR$(KM) + " BYTES ("

```

LACRAB
04/05/82
PAGE - 10

```

=====
      + STR$(INT(KM / SIZE * 100)) + "%)."
3220  GOSUB 3240
3230  GOTO 3320

3240                                     +-----+
      | PRINT OUT A LINE |
      +-----+

3250  IF NOT FN PAGE(N) THEN
      FOR T = 1 TO SKIP:
          PRINT " ":
          NEXT :
          SKIP = 6:
          N = N + 11:
          PRINT NAME$:
          PRINT TIME$:
          A$ = "PAGE - " + STR$(INT(N / S6) + 1):
          PRINT SPC( WIDTH - LEN(A$));A$:
          PRINT US$:
          PRINT " ":
          X = FRE(0)
3260  LX = LEN(LNE$):
      PRINT LNE$;SPC( SPACE);LEFT$(TXT$,WIDTH - SPACE - LX):
      IF (LEN(TXT$) + SPACE + LX) < = WIDTH THEN
          GO TO 3290:
          | TEXT FITS ON ONE LINE
3270  TXT$ = RIGHT$(TXT$,LEN(TXT$) + LX + SPACE - WIDTH):
      IF RM THEN
          FOR T = 1 TO KOMMENT - 2 - SPACE:
              TXT$ = " " + TXT$:
              NEXT
3280  LNE$ = " ":
          N = N + 1:
          GOTO 3250
3290  LNE$ = " ":
          TXT$ = " ":
          RM = 0:
          N = N + 1:
          IF BYTE = 0 THEN
              SPACE = SPACE - THN:
              THN = 0
3300  IF NFR THEN
          SPACE = SPACE + 3:
          NFR = 0
3310  RETURN

3320                                     +-----+
      | WRAP UP |
      +-----+

3330  IF COMMENTS THEN
      CX = 1:
      GOTO 1850

```

```

3340 PR# 0
3350 IF XREF THEN
      GO TO 2050
3360 PR# 1
3370 FOR I = 1 TO 75 - FN PAGE(N):
      PRINT " ";
NEXT

```

LACRAB
04/05/82
PAGE - 11

```

=====
3380 POKE 175,PEEK(103):
      POKE 176,PEEK(104):           I RESET EOP POINTERS
3390 IF PEEK(175) = 255 THEN
      POKE 176,PEEK(104) - 1
3400 POKE 103,1:
      POKE 104,8:                 I RESET SOP POINTERS
3410 PR# 0:
      HOME :
      PRINT N;" LINES PRINTED."
3420 PRINT CHR$(7);"LISTING COMPLETE...."
3430 END

```

```

+-----+
3440                               I DATA INITIALIZATION SECTION I
+-----+

```

```

3441 BYTE = 0:
      LOC = 0:
      B5 = 5:
      B6 = 2049
3450 DIM TKN$(127),COS(200),LINES(200),DF$(200)
3460 C1 = 178:
      C2 = 58:
      C3 = 196:
      C4 = 129:
      C5 = 130:
      C6 = 128:
      C7 = 173:
      C8 = 208:
      C9 = 34:
      A1 = 65:
      A2 = 90:
      A3 = 48:
      A4 = 57:
      A5 = 36:
      A6 = 37:
      A7 = 44:
      A8 = 127:
      B1 = 190:
      B2 = 132:
      B3 = 135:
      B4 = 131
3470 FOR I = 1 TO 107
3480   READ TKN$(I)
3490 NEXT I
3500 TKN$(36) = TKN$(36) + " ":
      TKN$(37) = TKN$(37) + " "
3510 DATA END,, ,DATA,INPUT,DEL,DIM,READ,GR,TEXT
3520 DATA PR#,IN#,CALL,PLOT,HLINE,VLINE,HGR2,HGR,HCOLOR=,HPLOT
3530 DATA DRAW,XDRAW,HTAB,HOME,ROT=,SCALE=,SHLOAD,TRACE,NOTRACE,NORMAL
3540 DATA INVERSE,FLASH,COLOR=,POP,VTAB,HIMEM,LOMEM,ONERR,RESUME,RECALL
3550 DATA STORE,SPEED=,LET,GOTO,RUN,IF,RESTORE,&,GOSUB,RETURN
3560 DATA REM,STOP,ON,WAIT,LOAD,SAVE,DEF,POKE,PRINT,CONT
3570 DATA LIST,CLEAR,GET,NEW,TAB(," TO",FN,SPC(,,AT
3580 DATA NOT," STEP"," +"," -"," *"," /"," ^"," AND"," OR"
3590 DATA ">"," ="," <"," SGN,INT,ABS,USR,FRE,SCRN(,PDL,POS
3600 DATA SQR,RND,LOG,EXP,COS,SIN,TAN,ATN,PEEK,LEN

```

LACRAB
04/05/82
PAGE - 12

```

=====
3610 DATA STR$,VAL,ASC,CHR$,LEFT$,RIGHT$,MID$
3620 HOME :
      WIDTH = 76:                 I ASSIGN PAGE WIDTH

```

```

3630 INPUT " ";NAME$:
      INPUT "PROGRAM NAME?";NAME$
3640 PRINT "DATE/TIME?";
3650 GET A$:
      I = ASC(A$):
      IF I = 13 THEN
          GO TO 3690
3660 IF I = 8 THEN
      TIMES$ = LEFT$(TIMES$,LEN(TIMES$) - 1):
          GOTO 3680
3670 TIMES$ = TIMES$ + A$
3680 VTAB 3:
      HTAB 11:
      PRINT TIMES$;:
          GOTO 3650
3690 PRINT " "
3700 FOR I = LEN(NAME$) TO WIDTH - 1
3710     NAME$ = " " + NAME$:
      NEXT
3720 FOR I = LEN(TIMES$) TO WIDTH - 1
3730     TIMES$ = " " + TIMES$:
      NEXT
3740 FOR I = 1 TO WIDTH:
      US$ = US$ + "=":
      NEXT
3750 SKIP = 3:
      BLK = 256
3760 LOC = 2051:
3770 EOP = PEEK(103) + PEEK(104) * BLK - 2:
3780 SPACE = 1:
      ! START OF PROGRAM
      ! END OF PROGRAM POINTER
      ! INITIAL SPACING AFTER LINE
      ! NUMBER
3790 S6 = 66
3800 DEF FN PAGE(N) = N - INT(N / S6) * S6:
3810 KOMMENT = 41:
3820 GOSUB 3850:
3830 HOME
3840 RETURN
3850
      +-----+
      | DISPLAY MENU |
      +-----+
3860 HOME :
      INVERSE
3870 FOR I = 1 TO 7
3880     READ J:
          IF J < > 0 THEN
              VTAB I:
              HTAB J:
              PRINT " ";:
                  GOTO 3880
3920 NEXT
3930 DATA 3,11,16,17,18,21,22,23,24,29,33,34,35,36,0
3940 DATA 3,10,12,15,19,21,25,28,30,33,37,0

```

```

=====
3950 DATA 3,9,13,15,21,25,27,31,33,37,0
3960 DATA 3,9,13,15,21,22,23,24,27,31,33,34,35,36,0
3970 DATA 3,9,10,11,12,13,15,21,23,27,28,29,30,31,33,37,0
3980 DATA 3,9,13,15,19,21,24,27,31,33,37,0
3990 DATA 3,4,5,6,7,9,13,16,17,18,21,25,27,31,33,34,35,36,0
4000 HTAB 1
4010 VTAB 9
4020 PRINT "===== "
4030 NORMAL
4040 VTAB 11:
      PRINT TAB( 15);"SYSTEM MENU"
4050 PRINT TAB( 19);"FOR"
4060 PRINT TAB( 15);"PROGRAM TO:"
4070 VTAB 15
4080 INVERSE :
      PRINT "L";:
          NORMAL :
          PRINT "IST ";

```



```

4090 INVERSE :
      PRINT "A";:
      NORMAL :
      PRINT "ND ";
4100 INVERSE :
      PRINT "C";:
      NORMAL :
      PRINT "ROSS ";
4110 INVERSE :
      PRINT "R";:
      NORMAL :
      PRINT "EFERENCE ";
4120 INVERSE :
      PRINT "A";:
      NORMAL :
      PRINT "PPLESOFT ";
4130 INVERSE :
      PRINT "B";:
      NORMAL :
      PRINT "ASIC"
4140 VTAB 17:
      HTAB 12
4150 PRINT "1) LISTING ONLY"
4160 VTAB 19:
      HTAB 12
4170 PRINT "2) CROSS REFERENCE ONLY"
4180 VTAB 21:
      HTAB 12
4190 PRINT "3) LISTING AND XREF"
4200 VTAB 23:
      HTAB 13:
      FLASH
4210 PRINT "WHICH OPTION?";:
      NORMAL
4220 GET A$
4230 IF A$ = "1" OR A$ = "3" THEN
      LST = 1:

```

! SET LISTING FLAG

LACRAB
04/05/82
PAGE - I4

```

=====
4240 IF A$ = "2" OR A$ = "3" THEN
      XREF = 1:
      ! SET CROSS REFERENCE FLAG
4250 IF A$ < "1" OR A$ > "3" THEN
      PRINT CHR$(7):
      GOTO 4200
4260 RETURN

```

4 GRAPHICS

Apple Color Filter <i>Stephen R. Berggren</i>	127
True 3-D Images <i>Art Radcliffe</i>	131
Apple Bits <i>Richard C. Vile</i>	136

Graphics

This section includes programs to help you understand and take advantage of the Apple II's superb graphics capabilities.

Dick Vile's "Apple Bits" makes use of the low-resolution graphics feature with utilities to build shapes and perform faster screen displays. Also included are interesting animation examples.

Art Radcliffe's "True 3-D Images" uses the versatility of the Apple's high-resolution system. By developing a stereo-pair of images, your flat monitor is given a new dimension of depth. Try out the noisy coaster and hold on to your seat!

"Apple Color Filter" by Stephen R. Berggren lets you erase any selected color from the high-resolution screen without affecting the other colors. This utility sheds light on how high-resolution color graphics work.

Apple Color Filter

by Stephen R. Berggren

This short machine-language subroutine will allow you to filter out any selected color from the Apple hi-resolution graphics screen.

One of the most fascinating capabilities of the Apple Graphics Tablet is its ability to separate the colors on the high-resolution graphics screen. It can act like a color filter, removing all colors from the screen except a chosen one. This can be extremely useful in doing computer art work, drawing graphs, and, of course, in game graphics. But now you can have a similar capability without buying the graphics tablet. Just use this Apple color filter program.

The color filter is a short machine-language program which can erase any selected color from the high-resolution screen while leaving the other colors unaffected. To use it, simply load it into page 3 of memory, starting at decimal 768. Then POKE a number from 1 to 4 into memory location 769 and run it with a call 768. The number POKEd into 769 determines what color is erased: 1 erases green, 2 erases violet, 3 erases blue and 4 erases orange. The program takes only about one-fourth of a second to filter the entire page-one hi-res screen.

If you are using only green, violet, blue and orange, everything works fine. But the Apple also draws in white — in fact two kinds of white. This can affect the results of the filter operation. The Apple makes its two whites by combining either green and violet (HCOLOR = 3) or blue and orange (HCOLOR = 7). The color filter "sees" the white as a combination of the two colors rather than as a separate color. Thus when told to erase green, it will erase all green, including the green part of any white that is made up of green and violet. This turns the white into violet. Of course, any white made up of blue and orange is left alone. So to erase white, simply erase the two colors that make it up. To avoid changing the white to another color, simply draw it in the colors that you do not plan to filter out later.

How the color filter works delves deeply into the mysteries of Apple color graphics. From what I have been able to deduce, it seems that each byte in the hi-res memory holds seven screen dots. Each set bit in the lower seven bits will turn on one dot. The highest bit determines whether the dots will be green and violet, or blue and orange. On even bytes, bits 0, 2, 4 and 6 create violet or blue while bits 1, 3 and 5 create green or orange. On odd bytes, this sequence is reversed. The color filter masks out all of the bits in the hi-res memory area that would create a particular color. By changing all of these color bits to 0, it eliminates the color. The comments in the source program listing give more detail on how the program operates.

Two bytes of zero-page memory are needed for the indirect addressing. The program uses bytes 6 and 7, but any two consecutive bytes can be used. As written, the program works only on hi-res page one, but by changing the values of LOSCRN to 40 and HISCRN to 60, you can make it work on hi-res page two. Finally, if you don't have an assembler, you can simply load the hexadecimal values listed in the table using the Apple monitor's data entry function.

The colors I have referred to here are the ones I get from my Apple on my television. The colors you get may be different. The best approach is to experiment with the program on your system to see what number inputs erase what colors. The Applesoft BASIC demonstration program listed here should give you a good idea of how the color filter works on your system.

```

0800      1 ;*****
0800      2 ;*
0800      3 ;* APPLE COLOR FILTER *
0800      4 ;* STEPHEN BERGGREN *
0800      5 ;*
0800      6 ;* COPYRIGHT (C) 1982 *
0800      7 ;* MICRO INK, INC. *
0800      8 ;* CHELMSFORD, MA 01824 *
0800      9 ;* ALL RIGHTS RESERVED *
0800     10 ;*
0800     11 ;*****
0800     12 ;
0800     13 ;
0800     14 ;PUT NUMBER FOR COLOR TO BE REMOVED IN $301
0800     15 ;1=GREEN, 2=VIOLET, 3=BLUE, AND 4=ORANGE
0800     16 ;WHITE #3 NOT AFFECTED BY 3 OR 4
0800     17 ;WHITE #7 NOT AFFECTED BY 1 OR 2
0800     18 ;
0800     19 ;TO RUN, 300G FROM MONITOR OR CALL 768 FROM BASIC
0800     20 ;
0006     21 SCRLOC EPZ $06 ;ZERO-PAGE LOC. FOR ADDRESSING
SCREEN
0020     22 LOSCRN EPZ $20 ;HI-BYTE OF ADDRESS OF SCREEN
START
0040     23 HISCRN EPZ $40 ;HI-BYTE OF SCREEN END
0800     24 ;
0300     25 ;
0300     26 ; ORG $300
0300     27 ; OBJ $800
0300     28 ;
0300 A2 00 28 ; LDX #$00 ;PUT COLOR VALUE IN X FOR TABL
E INDEXING
0302 A0 00 29 ; LDY #$00 ;PUT 0 IN Y FOR INDIRECT SCREE
N INDEXING
0304 A9 00 30 ; LDA #$00 ;SET SCREEN START ADDRESS IN S
CRLOC
0306 85 06 31 ; STA SCRLOC
0308 A9 20 32 ; LDA #LOSCRN
030A 85 07 33 ; STA SCRLOC+1
030C 34 ;
030C B1 06 35 ; EVNBYT LDA (SCRLOC),Y ;GET SCREEN BYTE
030E 30 08 36 ; BMI DOTAB2 ;IF BIT 7 SET, USE TABLE 2
0310 3D 45 03 37 ; AND TABLE1,X ;MASK OFF COLOR BITS USING TAB
LE 1
0313 91 06 38 ; STA (SCRLOC),Y ;PUT BACK THE BYTE
0315 4C 1D 03 39 ; JMP ODDBYT ;DO THE NEXT BYTE
0318 40 ;
0318 3D 47 03 41 ; DOTAB2 AND TABLE2,X ;MASK OFF COLOR BITS USING TAB
LE 2
031B 91 06 42 ; STA (SCRLOC),Y ;PUT BACK THE BYTE
031D 43 ;
031D E6 06 44 ; ODDBYT INC SCRLOC ;SET UP FOR NEXT SCREEN BYTE
031F B1 06 45 ; LDA (SCRLOC),Y ;GET SCREEN BYTE
0321 30 08 46 ; BMI DOTAB4 ;IF BIT 7 SET, USE TABLE 4
0323 3D 49 03 47 ; AND TABLE3,X ;MASK OFF COLOR BITS USING TAB
LE 3
0326 91 06 48 ; STA (SCRLOC),Y ;PUT BACK THE BYTE
0328 4C 30 03 49 ; JMP INCLOC ;GO INCREMENT SCRLOC
032B 50 ;
032B 3D 4B 03 51 ; DOTAB4 AND TABLE4,X ;MASK OFF COLOR BITS USING TAB
LE 4
032E 91 06 52 ; STA (SCRLOC),Y ;PUT BACK THE BYTE
0330 53 ;
0330 A9 00 54 ; INCLOC LDA #$00 ;INCREMENT SCRLOC LO
0332 38 55 ; SEC
0333 65 06 56 ; ADC SCRLOC
0335 85 06 57 ; STA SCRLOC
0337 90 D3 58 ; BCC EVNBYT ;IF NOT OVERFLOW, DO ANOTHER 2
BYTES
0339 A9 00 59 ; LDA #$00 ;INCREMENT SCRLOC HI
033B 38 60 ; SEC
033C 65 07 61 ; ADC SCRLOC+1
033E 85 07 62 ; STA SCRLOC+1

```

```

0340 C9 40      63      CMP #HISCRN      ;WAS THAT THE LAST PAGE?
0342 D0 C8      64      BNE EVNBYT      ;IF NOT, DO NEXT 2 BYTES
0344 60         65      RTS              ;ALL DONE!
0345           66      ;
0345 00 D5      67      TABLE1  HEX 00D5
0347 AA FF      68      TABLE2  HEX AAFF
0349 FF AA      69      TABLE3  HEX FFAA
034B D5 FF FF   70      TABLE4  HEX D5FFFD5AA
034E D5 AA      71      END

```

```

1  REM *****
2  REM *
3  REM *   COLOR FILTER DEMO *
4  REM *   BERGGREN *
5  REM *   COPYRIGHT (C) 1982 *
6  REM *   MICRO INK, INC. *
7  REM *   CHELMSFORD, MA 01824 *
8  REM *   ALL RIGHTS RESERVED *
9  REM *
10 REM *****
12 REM
14 HGR : HOME : VTAB 22
20 FOR I = 1 TO 7
30 HCOLOR= I
40 HPLOT 0,I * 10 TO 250,I * 10 + 50
50 NEXT I
55 FOR J = 1 TO 5000: NEXT J
60 FOR I = 1 TO 4
70 PRINT : PRINT : PRINT "COLOR FILTER INPUT: "I
80 POKE 769,I
90 CALL 768
100 FOR J = 1 TO 5000: NEXT J
110 NEXT I
120 TEXT
130 END

```

True 3-D Images

by Art Radcliffe

Create stereo-pair images for viewing without accessory devices. The pair of images can be fused into a three-dimensional pattern by placing a piece of paper between the viewer's eyes and the viewing screen so that each eye sees only the appropriate image. With practice the paper is no longer needed. The object used for demonstration is a three-dimensional Lissajous figure.

This article discusses genuine three-dimensional images such as seen through your grandparents' stereopticon, or through more recent systems that require colored eye filters for viewing. The present technique involves not a single projection of the object, but a pair of images which can be fused into one 3-D image without auxiliary contrivances.

The *Scientific American* has published articles accompanied by stereo-pair images, which can be fused into a stereo scene with a little practice. This program was inspired by success with such viewing. Some eye training is required, and some eye strain may be felt initially. What is required is that you stare off into the distance (eyeball axes essentially parallel) while focussing nearby. The muscles which direct your eyeball and the muscles which focus your lens are accustomed to working in a coordinated way for distant or for nearby objects; this muscular habit can readily be broken. It is not at all difficult for me now to glance at a pair of images on the screen from anywhere in the room, and see the 3-D pattern.

The viewing images are produced by running rays from each defined point of the object to points which correspond to eye locations. The object is behind the screen and the eyes are in typical viewing positions. Points are plotted where these rays intercept the display plane.

The object is defined near the origin of an X, Y, Z coordinate system, behind the screen plane. We can define object points using the notation: $(X1, Y1, Z1)$, define screen points with: $(X2, Y2, Z2)$, and define the eye locations using: $(X3, Y3, Z3)$. $Z2$, the screen distance from the origin, is set at 200 in the program, and $Z3$, the eye distance from the origin, is set at 300. $Y3$ is the same for each eye: 40; and the $X3$ values for the two eyes are 40 and 120. The direction from which the object is viewed can be altered by offsetting $X1$ and $Y1$.

Use of proportions leads us to the conclusion that $(X2-X1)/(Z2-Z1) = (X3-X1)/(Z3-Z1)$ and similarly, $(Y2-Y1)/(Z2-Z1) = (Y3-Y1)/(Z3-Z1)$. From these equations we can derive $X2 = X1 + M(X3-X1)$ and $Y2 = Y1 + M(Y3-Y1)$ where $M = (Z2-Z1)/(Z3-Z1)$.

Listing 1 is an embellishment, with sound effects, of the program as originally written (see listing 2).

Within the program there are variable substitutions: $(X, Y, Z) = (X1, Y1, Z1)$, $(A, B, C) = (X2, Y2, Z2)$ and $(D, F, G), (E, F, G) = (X3, Y3, Z3)$. A Lissajous pattern was chosen for viewing. It can be restricted to a rectangular area, derived from the property of the sine function, being bounded by 1 and -1 . In the program a raised sine is used by adding 1 (line 64) to avoid negative values. Thus, the X -coordinates of the object vary according to one sine function, the Y -coordinates of the object vary in a coordinated manner according to a second sine function, and the Z -coordinate varies according to a third sine function.

Random numbers are used to achieve an almost infinite variety of patterns. It is fun to watch the pattern take shape; the eye can go on a roller-coaster ride with the leading edge of the pattern as it develops on the screen.

There is an inherent limitation to this method in that the display area is limited to the space between the primary pair of images. Use of prismatic glasses might increase the available object size. The program is written for viewing on a twelve-inch diagonal screen. Users with other size displays may want to alter program parameters, first increasing or decreasing the X dimension for eye position by altering one or both of parameters D and E . It may also be useful to alter the scale factor N .

Interesting 3-D motion displays could be written in machine language. I can also imagine game possibilities, including visual 3-D Tic Tac Toe.

I have experimented with more general systems using color filters for viewing, and may report on this at some future time. I hope that readers will experiment with this viewing system, perhaps altering parameters of the given program or substituting another object. Data points in three dimensions might be seen as a 3-D swarm of points in which local clusters or correlations could be detected. This is a new way of seeing things.

```

1 REM *****
2 REM *
3 REM *      NOISY COASTER *
4 REM *      ART RADCLIFFE *
5 REM *
6 REM *      COPYRIGHT (C) 1982 *
7 REM *      MICRO INK, INC. *
8 REM *      CHELMSFORD, MA 01824*
9 REM *      ALL RIGHT RESERVED *
10 REM *
11 REM *****
12 HOME : POKE 36,12: PRINT "NOISY COASTER"
13 DIM A$(299): DIM B$(299): DIM H$(299): DIM S(299)
14 A = B = C = D = E = F = G = H = I = J = 0
15 K = L = M = N = O = P = Q = T = U = V = 0
16 W = X = Y = Z = 0:R = - 16336:S = .5:LL = 0
17 GOTO 630
18 REM -----
19 PRINT CHR$( 7): PRINT CHR$( 7): FOR A = 0 TO 1000: NEXT : PRINT CHR$(
    (7))
20 FOR P = 0 TO 299
21 A = PEEK (R)
22 HCOLOR= 3: REM FRONT OF TRAIN
23 B = A$(P):C = B$(P):D = H$(P)
24 E = B + 1:F = C + 1:G = D + 1
25 HPLOT B,F: HPLOT E,C: HPLOT E,F
26 HPLOT D,F: HPLOT G,C: HPLOT G,F
27 Q = P - 10
28 A = PEEK (R)
29 IF Q < 0 THEN Q = P + 289: REM 0<=Q<=360DEG
30 HCOLOR= 0: REM END OF TRAIN
31 B = A$(Q):C = B$(Q):D = H$(Q)
32 E = B + 1:F = C + 1:G = D + 1
33 HPLOT B,F: HPLOT E,C: HPLOT E,F
34 HPLOT D,F: HPLOT G,C: HPLOT G,F
35 A = PEEK (R): REM REPLOT TRACK ->
36 HCOLOR= 3: HPLOT B,C: HPLOT D,C
37 A = PEEK (R)
38 FOR Z = 0 TO LL - B$(P): NEXT : REM TRAIN SPEED
39 A = PEEK (R)
40 NEXT P
41 PRINT CHR$( 7)
42 RETURN
43 REM -----
44 FOR P = 0 TO 299: REM ESTABLISH PATTERN
45 X = S(I) + L:Y = 2 * S(J) + T:Z = S(K)
46 M = (C - Z) / (G - Z)
47 A = INT (S + X + M * (E - X)):A$(P) = A: REM LEFT X
48 B = INT (S + Y + M * (F - Y)) - 50:B$(P) = B: REM Y
49 H = INT (S + X + M * (D - X)):H$(P) = H: REM RIGHT X
50 HPLOT A,B: HPLOT A + 2,B: HPLOT H,B: HPLOT H + 2,B
51 IF LL < B THEN LL = B
52 I = I + U: IF I > 299 THEN I = 0
53 J = J + V: IF J > 299 THEN J = 0
54 K = K + W: IF K > 299 THEN K = 0
55 NEXT P
56 RETURN
57 REM -----
58 O = 8 * ATN (1) / 300: REM 360DEG/300
59 N = 40: REM OBJECT SCALE FACTOR
60 FOR A = 0 TO 299
61 S(A) = N * (1 + SIN (A * O)): REM SINE+1>0
62 NEXT A
63 C = 200: REM X COOR'S OF EYES
64 D = 120
65 E = 40: REM Y COOR'S OF EYES
66 F = 40
67 L = 150: REM X,Y,Z COOR'S OF OBJECT
68 T = 250
69 G = 300: REM # CYCLES IN X,Y,Z ->
70 U = INT (1 + 5 * RND (1))
71 V = INT (1 + 5 * RND (1)): IF V = U THEN 570
72 W = INT (1 + 5 * RND (1)): IF W = V OR W = U THEN 580
73 I = INT (300 * RND (1)): REM START POINTS

```

```

600 J = INT (300 * RND (1))
610 K = INT (300 * RND (1))
620 RETURN
625 REM -----
630 PRINT : PRINT : PRINT "   CREATED BY ART RADCLIFFE, ANN ARBOR   ": PRINT

640 PRINT : PRINT "PLACE 8 INCH BY 12 INCH CARDBOARD           "
650 PRINT "BETWEEN SCREEN AND TIP OF NOSE SO EACH           "
660 PRINT "EYE SEES ONLY IT'S IMAGE.  SOME EYE               "
670 PRINT "TRAINING IS NECESSARY.                                "
680 PRINT : PRINT : PRINT : PRINT : PRINT
690 PRINT "PLEASE BE PATIENT WHILE I MEDITATE TO               "
700 PRINT "GET MYSELF READY FOR THIS....."
705 REM -----
710 GOSUB 440 REM INITIALIZE
720 HOME : HGR : HCOLOR= 3
730 LL = 0: REM LOWEST POINT
740 GOSUB 310 REM LAY TRACK
750 FOR A = 0 TO 999: NEXT
760 GOSUB 70 REM HOLD TIGHT!
770 FOR A = 0 TO 3000: NEXT
780 GOSUB 490 REM REINITIALIZE
790 GOTO 720 REM START OVER
800 END

```

```

1  REM *****
2  REM *
3  REM *   LISSAJOUS FIGURES *
4  REM *   ART RADCLIFFE   *
5  REM *
6  REM *   COPYRIGHT (C) 1982 *
7  REM *   MICRO INK, INC.   *
8  REM *   CHELMSFORD, MA 01824 *
9  REM *   ALL RIGHTS RESERVED *
10 REM *
11 REM *****
14 HGR : HCOLOR= 3: PRINT : PRINT "WAIT"
16 DIM S(199)
18 A = B = C = D = E = F = G = H = I = S = 0
20 J = K = L = M = N = O = P = X = Y = Z = 0
22 GOTO 56
24 FOR P = 0 TO 199
26 X = S(I) + L
28 X = S(J) + T
30 Z = S(K)
32 M = (C - Z) / (G - Z)
34 A = INT (S + X + M * (E - X))
36 B = INT (S + Y + M * (F - Y))
38 H = INT (S + X + M * (D - X))
40 HPLOT A,B: HPLOT H,B
42 I = I + U: IF I > 199 THEN I = 0
44 J = J + V: IF J > 199 THEN J = 0
46 K = K + W: IF K > 199 THEN K = 0
48 NEXT
50 FOR Z = 0 TO 5000: NEXT Z
52 HGR
54 GOTO 22
56 O = .04 * ATN (1)
58 N = 40
60 FOR A = 0 TO 199
62 B = A * O
64 S(A) = N * (1 + SIN (B))
66 NEXT
68 C = 200
70 D = 120
72 E = 40
74 F = 40
76 G = 300
78 T = 250
80 L = 150
82 U = INT (1 + 5 * RND (1))
84 V = INT (1 + 5 * RND (1)): IF V = U THEN 84
86 W = INT (1 + 5 * RND (1)): IF W = V OR W = U THEN 86
88 I = INT (199 * RND (1))
90 J = INT (199 * RND (1))
92 K = INT (199 * RND (1))
94 S = .5
96 POKE 49234,0
98 GOTO 24

```

Apple Bits

by Richard C. Vile

This article describes several aids to faster and more efficient low-resolution graphics programming, including machine-language routines.

Part 1

This is the first part in a series dealing with the use of Apple II low-resolution graphics features. Some techniques will be described that use machine language to enhance the speed of graphics applications and reduce the amount of memory required in order to represent certain screen patterns.

The basic techniques described will enable you to display patterns 8×8 in size or smaller, and consisting of a single color. Larger patterns must be constructed from smaller pieces which fit these requirements. A modification of the machine-language routine will allow multiple colors to be obtained by overlaying.

Bit-encoding a Picture

Consider the following eight hexadecimal numbers:

38,38,12,FE,90,28,44,83

Believe it or not, they contain a picture! To see how, let's first rewrite the numbers in binary, using the following table to convert each hex digit into a 4-bit binary "nibble:"

Hex	Binary		
0	0000	8	1000
1	0001	9	1001
2	0010	A	1010
3	0011	B	1011
4	0100	C	1100
5	0101	D	1101
6	0110	E	1110
7	0111	F	1111

We arrive at the following numbers:

```

0 0 1 1 1 0 0 0
0 0 1 1 1 0 0 0
0 0 0 1 0 0 1 0
1 1 1 1 1 1 1 0
1 0 0 1 0 0 0 0
0 0 1 0 1 0 0 0
0 1 0 0 0 1 0 0
1 0 0 0 0 0 1 1

```

Do you see the picture yet? Just in case you don't, let's transform the pattern of 0's and 1's onto "graph paper" by superimposing a grid of squares on top of the above list, like so:

0	0	1	1	1	0	0	0
0	0	1	1	1	0	0	0
0	0	0	1	0	0	1	0
1	1	1	1	1	1	1	0
1	0	0	1	0	0	0	0
0	0	1	0	1	0	0	0
0	1	0	0	0	1	0	0
1	0	0	0	0	0	1	1

Now, erase all the 0's and completely blacken the squares containing the 1's. That gives the grid shown next:

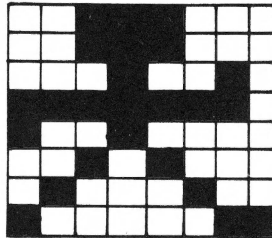

Now, of course, you see the "picture." Erasing the grid lines should make the correspondence with the lo-res display pretty obvious as well. The question now becomes: "How do we turn the above process into a program?"

Shown in listing 1 is a machine-language program which will carry out the process. It "assumes" that certain information has been set up for it. This information will be illustrated by listing 2 (in Integer BASIC).

The BASIC program does a series of POKEs which set up the machine-language routine's information:

```
12 POKE 2048,7: POKE 2049,7
```

indicates the width and height of the patterns to be displayed.

28 POKE 36,COL: POKE 37,ROW

indicates the ROW and COLUMN of the lo-res screen where the upper-left corner of the pattern to be displayed will be.

60 POKE 60,(3072 + OFFSET)MOD 256

65 POKE 61,(3072 + OFFSET)/256

stores the address in Apple II RAM where the numerical codes for the pattern to be displayed begin.

The machine-language program is invoked by the line:

70 CALL 2058

Running the Fireworks Animation

The numerical data the program uses must first be entered into memory. This data resides at locations C00 to D27 (3072-3367). Once you have entered it using the monitor, save it on tape (C00.D27W) or on disk

```
*3DOG
>BSAVE SPARKS,A$C00,L$127
```

to avoid keying it in again later. Likewise, enter the machine-language program using the monitor or the mini-assembler and save it:

```
*800.857W (Tape)
or
*3DOG
>BSAVE APPLE-BITS,
A$800,L$57 (Disk)
```

To run the program, you should issue the command

```
>LOMEM:4096
```

so that BASIC doesn't clobber the machine-language program.

Assuming you are using a disk-based system, the entire sequence of commands needed to run the animation would be:

```
>BLOAD APPLE-BITS
>BLOAD SPARKS
>LOMEM:4096
>RUN FIREWORKS
```

(If you'd rather not key in long command sequences, cook up an EXEC file with the commands in it.)

Listing 1

```

080A-  A5 30      LDA  $30
080C-  8D 04 08  STA  $0804
080F-  AC 00 08  LDY  $0800
0812-  8C 03 08  STY  $0803
0815-  CE 03 08  DEC  $0803
0818-  30 31      BMI  $084B
081A-  AE 01 08  LDX  $0801
081D-  8E 02 08  STX  $0802
0820-  CA        DEX
0821-  30 F2      BMI  $0815
0823-  BD 50 08  LDA  $0850,X
0826-  AC 03 08  LDY  $0803
0829-  31 3C      AND  ($3C),Y
082B-  D0 04      BNE  $0831
082D-  A9 00      LDA  #$00
082F-  85 30      STA  $30
0831-  A5 24      LDA  $24
0833-  18        CLC
0834-  6D 03 08  ADC  $0803
0837-  A8        TAY
0838-  A5 25      LDA  $25
083A-  8E 02 08  STX  $0802
083D-  6D 02 08  ADC  $0802
0840-  20 00 F8  JSR  $F800
0843-  AD 04 08  LDA  $0804
0846-  85 30      STA  $30
0848-  4C 20 08  JMP  $0820
084B-  60        RTS
084C-  80        ???
084D-  10 10      BPL  $085F
084F-  F8        SED
0850-  01 02      ORA  ($02,X)
0852-  04        ???
0853-  08        PHP
0854-  10 20      BPL  $0876
0856-  40        RTI
0857-  80        ???
0858-  A8        TAY
0859-  B0 08      BCS  $0863
085B-  28        PLP
*
```

Listing 2

```

1 REM *****
2 REM *
3 REM *      FIREWORKS      *
4 REM *      R. C. VILE      *
5 REM *
6 REM *      COPYRIGHT (C) 1982 *
7 REM *      MICRO INK, INC.  *
8 REM *      CHELMSFORD, MA 01824*
9 REM *      ALL RIGHTS RESERVED*
10 REM *
12 REM *****
14 GR : PRINT : PRINT : PRINT
15 POKE 2048,7: POKE 2049,7
17 ROW=7+ RND (27)
20 COL=7+ RND (27)
25 COLOR= RND (15)+1
28 POKE 36,COL: POKE 37,ROW
30 FOR J=1 TO RND (10)
40 SPARK=1+ RND (20)
50 OFFSET=SPARK*7
60 POKE 60,(3072+OFFSET) MOD 256
65 POKE 61,(3072+OFFSET)/256
70 CALL 2058
72 FOR DE=1 TO 25: NEXT DE
75 NEXT J
80 COLOR=0: FOR J=0 TO 6: HLIN COL,COL+6 AT ROW+J: NEXT J
85 GOTO 17
```

Part 2

The Pattern Maker Program

This program lets you create patterns and store them in tables for subsequent use by animation programs. It begins by asking a couple of questions:

```
HEIGHT AND WIDTH OF PATTERNS?
TABLE ADDRESS IN DECIMAL?
```

The patterns created may be *up to* 8 rows high by 8 columns wide, but may be smaller than that as well. For example, one set of patterns that I use consists of 7 rows by 5 columns. They form a "giant" character set that may be used to create billboard messages on the Apple screen. The table of patterns is stored in Apple RAM and manipulated by PEEKs and POKEs. Thus, it is necessary to tell the program where in memory the table is located. I typically store tables at 3072 (\$C00). The tables must be saved on tape or disk for eventual use by animation programs.

The program will display a rectangular border enclosing an area equal in size to the patterns specified, as shown in figure 1. Inside the pattern border you'll see a blinking cursor. You may move this cursor about, inside the border, and either add or delete parts of a pattern in the process.

The pattern maker will respond to any of the following commands:

```
PATTERN
VERIFY
MODIFY
RECORD
SAME
HELP
QUIT, BYE, STOP, EXIT
```

The commands are typed in full, or abbreviated to the first letter. If you forget what the commands are, simply type "HELP" or "H" and the menu of commands will be listed for you. (Note: You will probably lose any pattern in progress if you do that.)

The commands have the following effects:

PATTERN: The area inside the border is erased, the cursor appears inside, and the user may begin creating a new pattern.

MODIFY: Recalls a given pattern from the table, so the user may modify it.

SAME: Returns to the same pattern as the one most recently created or modified (allows the user to recover from accidentally striking "ENTER" while creating a pattern.)

VERIFY: Displays the numeric codes for the pattern under construction or modification. Mainly included for debugging the pattern maker program itself.

HELP: Displays the menu of commands.

QUIT, BYE, STOP, EXIT: Cause the termination of the program. Note that the screen is cleared and returned to TEXT mode.

The program operates in mixed low-resolution graphics mode and uses the bottom four lines of the screen for entering commands and prompts. The program will prompt you by typing

COMMAND?

and then wait for a response. If any of the above commands are entered, the program will take the corresponding action, otherwise it simply reprompts the user. The "P", "M", and "S" commands will transfer the cursor inside the rectangle on the graphics portion of the screen. While there, you may enter "cursor control keys" or "pattern control keys" to shift the cursor around the pattern and create or erase parts of the pattern.

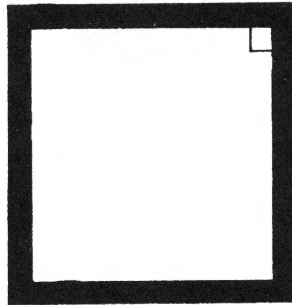

Figure 1: Building the Pattern

The cursor control keys and their results are listed in table 1 and the pattern control keys and their results are listed in table 2.

When **RECORDing** or **MODIFYing** patterns, the program will request a **KEY** to associate with the pattern. You should respond to this request by simply striking the desired key (do not hit **ENTER**, unless that is the desired key). Control keys (except for **Control-C**) are included. The association that is made "internally" by this is as follows: The program converts the ASCII value of the key struck to a table offset. This offset is then used when storing or retrieving the corresponding pattern from memory. The same idea will be used by animation programs in order to point the machine language driver at the correct positions in memory for a given pattern.

The pattern-maker program does not **LOAD** and **SAVE** the pattern tables itself. This is the responsibility of the user. For example, suppose you have created a table which starts at location **\$C00** and extends as far as **\$FFF**. After exiting the pattern-maker program and returning to the Integer BASIC command

level, you would give the following command, assuming that you have a disk-based system:

```
BSAVE PATTERN TABLE XYZ,A$C00,L$7FF
```

To save the same table on tape, you would enter the monitor and (after setting up your recorder, etc.) type

```
*C00.FFFW
```

and wait for the monitor to write it all out to the cassette.

Table 1

KEY	EFFECT
—>	Move the cursor one column to the right. If the cursor is already at the far right of the rectangle, then "wrap" around to the far left of the pattern, but one row further down. If at the extreme bottom right of the pattern, then "wrap" around to the extreme top left of the pattern.
R	Same as —> .
<—	Move the cursor one column to the left. At the extreme positions "wrap" around in a fashion analogous to that described above for the —> or R keys.
L	Same as <— .
U	Move the cursor up one row. (Wrap around also)
D	Move the cursor down one row. (Wrap also)
ENTER	Return the cursor to the command area of the screen.
ESC	Same as for "ENTER".

Table 2

KEY	EFFECT
+	Add a solid blob to the pattern in the position indicated by the current location of the cursor.
-	Erase the part of the pattern (if any) located at the current position of the cursor.

Note: If you store your tables in low memory, be sure to protect them from the BASIC program itself. For example, when I use the area from \$C00 (decimal 3072) to \$FFF, I first issue the command:

```
LOMEM: 4096
```

Final Note

The pattern-maker program uses the machine-language driver program (in order to support the Modify command). Thus, the following complete sequence of commands would be used to run the pattern maker to add or modify patterns previously saved in file BPATS:

```
> BLOAD BPATS  
> BLOAD APPLE-BITS  
> LOMEM: 4096  
> RUN PATTERN MAKER
```

If no previous file of patterns, such as BPATS, is being used, then the first command in the sequence may be omitted.

```

0 REM *****
1 REM *
2 REM *      PATTERN MAKER
3 REM *      R. C. VILE
4 REM *
5 REM *      COPYRIGHT (C) 1982
6 REM *      MICRO INK, INC.
7 REM *      CHELMSFORD, MA. 01824
8 REM *      ALL RIGHTS RESERVED
9 REM *****
10 DIM PATTERN(7),BITS(7),A$(25): GOSUB 10000
11 INPUT "COMMAND? ",A$: IF A$="P" OR A$="PATTERN" THEN GOSUB 50
12 IF A$="V" OR A$="VERIFY" THEN GOSUB 1000
13 IF A$="M" OR A$="MODIFY" THEN GOSUB 1500
14 IF A$="R" OR A$="RECORD" THEN GOSUB 2000
15 IF A$="S" OR A$="SAME" THEN GOSUB 52
16 IF A$="H" OR A$="HELP" THEN GOSUB 2500
17 IF A$="Q" OR A$="QUIT" OR A$="BYE" OR A$="STOP" OR A$="EXIT" THEN GOTO
3025
45 GOTO 11
50 FOR I=0 TO 7:PATTERN(I)=0: NEXT I: GR
51 COLOR=1: HLINE 14,14+WIDTH+1 AT 14: HLINE 14,14+WIDTH+1 AT 14+HEIGHT+
1: VLINE 14,14+HEIGHT+1 AT 14: VLINE 14,14+HEIGHT+1 AT 14+WIDTH+1
52 SAVCOLR= SCRN(15+COL,15+ROW):KEY= PEEK (KBD): IF KEY>=128 THEN 57
54 COLOR=15: PLOT 15+COL,15+ROW: FOR I=0 TO 10: NEXT I: COLOR=0: PLOT
15+COL,15+ROW: FOR I=0 TO 10: NEXT I: IF SAVCOLR#15 THEN 52
56 COLOR=15: PLOT 15+COL,15+ROW: COLOR=0: GOTO 52
57 POKE CLR,0
58 IF KEY=141 OR KEY=155 THEN RETURN : COLOR=15
60 IF KEY# ASC("R") AND KEY#149 THEN 70:COL=COL+1: IF COL<WIDTH THEN 52
:ROW=ROW+1:COL=0: IF ROW<HEIGHT THEN 52:ROW=0: GOTO 52
70 IF KEY# ASC("L") AND KEY#136 THEN 80:COL=COL-1: IF COL>=0 THEN 52:COL=
WIDTH-1:ROW=ROW-1: IF ROW>=0 THEN 52:ROW=HEIGHT-1:COL=WIDTH-1: GOTO
52
80 IF KEY# ASC("U") THEN 90:ROW=ROW-1: IF ROW>=0 THEN 52:ROW=HEIGHT-1:
COL=COL-1: IF COL>=0 THEN 52:COL=WIDTH-1: GOTO 52
90 IF KEY# ASC("D") THEN 100:ROW=ROW+1: IF ROW<HEIGHT THEN 52:ROW=0:COL=
COL+1: IF COL<WIDTH THEN 52:COL=0: GOTO 52
100 IF KEY# ASC("+") THEN 110:VALUE=1: GOSUB 500: GOTO 52
110 IF KEY# ASC("-") THEN 120:VALUE=0: GOSUB 500: GOTO 52
120 VTAB 23: PRINT "INVALID KEY": FOR K=1 TO 25: NEXT K: VTAB 23: TAB 1
: PRINT " ": GOTO 52
500 TEMP=PATTERN(COL)
510 FOR B=0 TO 7:BITS(B)=TEMP MOD 2:TEMP=TEMP/2: NEXT B
515 BITS(ROW)=VALUE
517 TEMP=BITS(7)
520 FOR B=6 TO 0 STEP -1
530 TEMP=2*TEMP+BITS(B)
540 NEXT B
550 PATTERN(COL)=TEMP
551 IF VALUE=0 THEN COLOR=0
555 PLOT 15+COL,15+ROW
557 COLOR=15
560 RETURN
1000 FOR I=0 TO 7: PRINT PATTERN(I); " ";: NEXT I
1010 RETURN
1500 INPUT "WHICH KEY?"
1505 KEY= PEEK (KBD): IF KEY<128 THEN 1505
1510 POKE CLR,0:OFFSET=(KEY-128)*WIDTH
1512 POKE 2048,WIDTH: POKE 2049,HEIGHT
1515 POKE 60,(ADDR+OFFSET) MOD 256
1520 POKE 61,(ADDR+OFFSET)/256
1522 GR
1525 POKE 36,15: POKE 37,15
1530 COLOR=15: CALL 2058
1532 POKE 36,0: POKE 37,23
1535 COLOR=1: HLINE 14,14+WIDTH+1 AT 14: HLINE 14,14+WIDTH+1 AT 14+HEIGHT+
1
1540 VLINE 14,14+HEIGHT+1 AT 14: VLINE 14,14+HEIGHT+1 AT 14+WIDTH+1
1545 FOR I=0 TO WIDTH-1
1550 PATTERN(I)= PEEK (ADDR+OFFSET+I)
1555 NEXT I
1560 GOTO 52
2000 PRINT "WHICH KEY?"
2001 KEY= PEEK (KBD): IF KEY<128 THEN 2001

```

```

2002 POKE CLR,0:KEY=KEY-128:OFFSET=KEY*WIDTH
2005 FOR I=0 TO WIDTH-1
2010 POKE ADDR+OFFSET+I,PTTERN(I)
2020 NEXT I
2030 RETURN
2500 REM  HELP SUBROUTINE
2501 REM
2510 TEXT : CALL -936
2515 VTAB 2: TAB 2: PRINT "COMMAND";: TAB 12: PRINT "EFFECT"
2520 TAB 2: PRINT "=====";: TAB 12: PRINT "====="
2525 VTAB 5: TAB 2: PRINT "PATTERN";: TAB 12: PRINT "STARTS A NEW PATTERN"

2526 PRINT
2527 TAB 2: PRINT "MODIFY";: TAB 12: PRINT "CALLS UP AN OLD PATTERN FOR"

2529 TAB 12: PRINT "MODIFICATIONS."
2530 PRINT
2531 TAB 2: PRINT "RECORD";: TAB 12: PRINT "SAVES CURRENT PATTERN IN THE"

2533 TAB 12: PRINT "PATTERN TABLE. IT WILL BE"
2535 TAB 12: PRINT "ASSOCIATED WITH A KEY."
2536 PRINT
2537 TAB 2: PRINT "SAME";: TAB 12: PRINT "RETURNS TO PATTERN AREA"
2539 TAB 12: PRINT "WITHOUT DESTROYING THE"
2541 TAB 12: PRINT "CURRENT PATTERN."
2542 PRINT
2543 TAB 2: PRINT "HELP";: TAB 12: PRINT "DISPLAYS THIS MESSAGE."
2585 PRINT : TAB 2: PRINT " TO QUIT, TYPE ANY OF THE FOLLOWING:"
2587 TAB 2: PRINT " 'QUIT','Q','STOP','BYE', OR 'EXIT'"
2590 GOSUB WAIT
2599 RETURN
3000 REM  WAIT SUBROUTINE
3001 REM
3005 POKE CLR,0
3010 KEY= PEEK (KBD): IF KEY<128 THEN 3010
3015 POKE CLR,0
3020 IF KEY# ASC("Q") THEN RETURN
3025 TEXT : CALL -936: END
10000 TEXT : CALL -936
10005 KBD=-16384:CLR=-16368:WAIT=3000
10007 FOR I=0 TO 7:PTTERN(I)=BITS(I)=0: NEXT I
10010 INPUT "HEIGHT OF PATTERNS ",HEIGHT
10011 IF HEIGHT<9 THEN GOTO 10013
10012 HEIGHT=8: VTAB 23: PRINT "DEFAULTING TO HEIGHT = 8 ";
10013 TAB 1: VTAB 3
10015 INPUT "WIDTH OF PATTERNS ",WIDTH
10016 IF WIDTH<9 THEN GOTO 10018
10017 WIDTH=8: VTAB 23: PRINT "DEFAULTING TO WIDTH = 8 ";
10018 TAB 1: VTAB 5
10020 INPUT "TABLE ADDRESS IN DECIMAL ",ADDR
10025 CALL -958
10030 RETURN

```

Part 3

Now I'll discuss the use of the machine-language driver program and the pattern-maker program in the creation of "animations" for the low-resolution screen. The major example considered is a program for converting the lo-res screen into a terminal that displays "giant" letters and other patterns. (Note: the information displayed is *not* passed on as commands to BASIC, although with some effort that could be accomplished.)

Giant Letters — The Patterns

The first step in creating any Apple Bits application is to design a set of patterns. In this case, the patterns will be letters and other characters that can be plotted on the screen when their associated keys are struck. The pattern size that works with the Integer BASIC program presented is 5×7 . By suitable modifications to that program (left as an exercise to the reader), other character pattern sizes can be used as well.

To design your character set, run the pattern-maker program. Following the instructions given in Part 2, create patterns for each character on the Apple keyboard. You can also create patterns for keys which do not produce displayable graphics (control keys). The pattern maker will accept control keys as well as normal keys. For example, for the keys "A," "?," and " G" (Control-G), you might use the following:

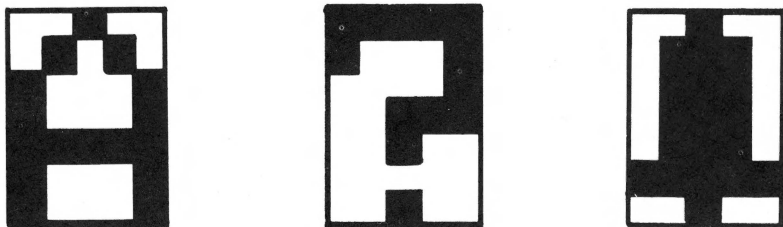

When you are satisfied with your results, stop the pattern maker by typing "Q" or "QUIT" and then BSAVE your patterns. This takes a little calculating. Suppose your pattern table was started at location 3072 (decimal, or \$C00 hex) and the patterns are, of course, 5×7 in size. To store the patterns for the characters Control-A through Z, you would consume 5×96 , or 480 bytes. Thus,

```
BSAVE LETTERS,A3072,L480
```

would do. I normally just reserve all the space from \$C00 to \$FFF for patterns; that is more than enough, even for 96 patterns of 8×8 characters. I simply use the command:

```
BSAVE LETTERS,A$C00,L$3FF
```

Once you have created your patterns, the program to "drive" the screen is shown in listing 1. Don't forget to set LOMEM:

```
> LOMEM: 4096
```

There are some generally useful points to note in this program. You may be able to make use of them in other programs of your own.

In lines 10 and 15:

```
10 GR : POKE -16302,0 : COLOR=0
```

```
15 FOR I=40 TO 47 : HLIN 0,39 AT I : NEXT I
```

The POKE statement selects FULL SCREEN graphics. This causes any information already displayed on the bottom four lines of the screen to suddenly change to "living color." Line 15 blackens the bottom four lines again.

In line 12:

```
12 POKE 32,0 : POKE 33,40 : POKE 34,0 : POKE 35,24
```

These statements set the "text window" back to the full screen. But why do that? This is a graphics program, but it is also a text program as well: the letters are just a bit larger than usual! So when your screen fills with maxi-alphabets, how do you make room for more? Scroll! Look at line 60:

```
60 FOR J=1 TO 4 : CALL -912 : COLOR=0 : HLIN 0,39 AT 47 : NEXT J
```

The routine at -912 is the normal monitor routine for text scrolling. It uses the settings of the window variables in locations 32 - 35 to determine what portion of the screen to scroll. The GR statement sets these variables so that only the bottom four lines will scroll. Our POKES in line 12 have fooled the monitor into thinking that the whole screen should be scrolled. The Apple will then scroll the graphics display, without a whimper. Since the lines which appear at the bottom during the scrolling process will be WHITE, we use the HLIN statement to re-blacken them.

If you study the listing further, you will discover that the left and right arrow keys will function in a manner similar to their normal text interpretation. In addition, the ENTER key will cause the display to proceed to the beginning of the next "line." The ESC key functions as a "Clear Screen" key. It also causes the next character to appear at the upper left-hand corner of the display. I leave it to you to dig out the details of these points.

A Random Walk

Listing 2 presents an animation. It causes a little "man" to walk across the screen from the lower right corner to the upper left corner. The actual path taken is different each time, consisting of a random pattern of moves to the left and/or up.

The data for the patterns of program 2 is presented in listing 3.

Computer Choo-Choo

Listing 4 moves a locomotive across the screen from right to left. The train gives off "smoke" as it goes and periodically toots its whistle. The whistle is produced by calling a routine in the Apple Programmer's Aid ROM. If you do not have this installed in your Apple, you will have to locate and remove the CALL statements in the program. They could be replaced by CALLs to your own tone-producing routine.

The data for the locomotive program is presented in listing 5.

Notes on Implementing Animations

In both the random walk program and the locomotive program, only a small number of patterns was needed. Notice that the pattern selected for display by the programs at any given time is specified by a small positive number. For example, examine lines 535 to 540 of listing 2. The patterns are associated with these numbers because of the pattern-maker program. The control keys correspond to numbers 1 through 26. Thus, when you use the pattern maker to create a set of patterns and record a particular one using, say, Control-E, then that pattern becomes the 5th pattern in the table.

To set up the address of this pattern (so the machine-language driver knows which one to display), the statements in lines 536 and 537 of listing 2 would be used. These are similar to the statements appearing in lines 60 and 65 of the Fireworks Animation presented in Part 1.

Let's review the general form of the set-up instructions:

```
POKE 60, (TABLE + OFFSET)MOD 256
```

```
POKE 61, (TABLE + OFFSET)/256
```

where,

TABLE — represents the address in Apple II RAM of the very beginning of the Pattern Table. In all of our examples this has been 3072, decimal. However, it could be other values as well.

Note: The numbering of the entries in the table actually begins at 0. The 0th entry is inaccessible, since the pattern maker cannot accept a key whose character code is 0. Also, the entry in the table which corresponds to the Control-C key (number 3) will always contain "garbage." This is the reason for the IF test in line 535 of listing 2.

OFFSET —represents the distance (in bytes) from the beginning of the pattern table at which a given pattern may be found. This offset may be calculated using the formula:

$$\text{OFFSET} = \text{WIDTH} * \text{KEY}$$

where,

WIDTH — is the width of the patterns in the table.

KEY — is the number of the pattern you wish to retrieve.

Listing 1

```

0 REM *****
1 REM *
2 REM *      LARGE DRIVER      *
3 REM *      R. C. VILE        *
4 REM *
5 REM *      COPYRIGHT (C) 1982 *
6 REM *      MICRO INK, INC.   *
7 REM *      CHELMSFORD, MA. 01824 *
8 REM *      ALL RIGHTS RESERVED *
9 REM *****
12 GOSUB 1000
15 FOR I=40 TO 47: HLIN 0,39 AT I: NEXT I
20 ROW=0:COL=0
22 COLOR= RND (15)+1
25 GOSUB 700
30 POKE 36,COL: POKE 37,ROW
35 POKE 60,(3072+5*K1) MOD 256
40 POKE 61,(3072+5*K1)/256
42 COLOR= RND (15)+1
45 CALL 2058
50 COL=COL+6: IF COL<36 THEN 25
55 COL=0:ROW=ROW+8: IF ROW<=40 THEN 25
60 FOR J=1 TO 4: CALL -912: COLOR=0: HLIN 0,39 AT 46: HLIN 0,39 AT 47:
  NEXT J
65 COLOR= RND (15)+1
70 ROW=40:COL=0: GOTO 25
700 KEY= PEEK (KBD): IF KEY<128 THEN 700
705 POKE CLR,0
710 K1=KEY-128
712 IF K1#27 THEN 718
713 COLOR=0: FOR I=0 TO 47: HLIN 0,39 AT I: NEXT I: COLOR= RND (15)+1
715 ROW=0:COL=0: GOTO 700
718 IF K1=13 THEN 785
719 IF K1=7 THEN 775
720 IF (K1#8 AND K1#21) THEN RETURN
722 IF K1#21 THEN 725
723 K1=32: RETURN
725 COL=COL-6: IF COL>=0 THEN 750
730 COL=30:ROW=ROW-8: IF ROW>=0 THEN 750
735 ROW=0:COL=0
750 COLOR=0
755 FOR J=0 TO 7
760 HLIN COL,COL+5 AT ROW+J
765 NEXT J
770 COLOR= RND (15)+1: GOTO 700
775 PRINT "": RETURN
785 ROW=ROW+8: IF ROW=48 THEN 790
787 COL=0: GOTO 700
790 COLOR=0
792 FOR J=1 TO 4: CALL -912
793 HLIN 0,39 AT 46: HLIN 0,39 AT 47
794 NEXT J
799 ROW=40:COL=0: COLOR= RND (15)+1: GOTO 700
1000 KBD=-16384:CLR=-16368
1009 POKE 2048,5: POKE 2049,7
1010 GR : POKE -16302,0: COLOR=0
1015 POKE 32,0: POKE 33,40: POKE 34,0: POKE 35,24
1016 RETURN

```

Listing 2

```

0 REM *****
1 REM *
2 REM *          RANDOM WALK          *
3 REM *          R. C. VILE          *
4 REM *
5 REM *          COPYRIGHT (C) 1982   *
6 REM *          MICRO INK, INC.     *
7 REM *          CHELMSFORD, MA. 01824 *
8 REM *          ALL RIGHTS RESERVED  *
9 REM *****
10 MOVE=500: GR : POKE -16302,0: COLOR=0
15 FOR I=40 TO 47: HLIN 0,39 AT I: NEXT I
21 POKE 2048,8: POKE 2049,8
32 POKE 36, RND (32): POKE 37, RND (40)
35 COLOR= RND (15)+1
40 D= RND (2)
45 IF D#0 THEN 55
50 DX=0:DY=-1: GOSUB MOVE: GOTO 35
55 IF D#1 THEN 65
60 DX=-1:DY=0: GOSUB MOVE: GOTO 35
65 IF D#2 THEN 75
70 DX=1:DY=0: GOSUB MOVE: GOTO 35
75 DX=-1:DY=0: GOSUB MOVE: GOTO 35
500 COL= PEEK (36):ROW= PEEK (37)
505 COL=COL+DX: IF COL<32 THEN 510: GOSUB 600:COL=0
510 IF COL>0 THEN 515: GOSUB 600:COL=32
515 ROW=ROW+DY: IF ROW<40 THEN 520: GOSUB 600:ROW=0
520 IF ROW>0 THEN 530: GOSUB 600:ROW=40
530 POKE 36,COL: POKE 37,ROW
535 KEY= RND (5)+1: IF KEY=3 THEN 535
536 POKE 61,(3072+8*KEY)/256
537 POKE 60,(3072+8*KEY) MOD 256
540 CALL 2058
545 FOR TIME=1 TO 25: NEXT TIME
555 COLOR=0
560 HLIN COL,COL+7 AT ROW+7
562 VLIN ROW,ROW+7 AT COL+7
570 RETURN
600 COLOR=0: FOR I=0 TO 7: HLIN COL,COL+7 AT ROW+I: NEXT I
610 RETURN

```

Listing 3

```

0C00- FF FF FF 15 1F 7E 7C 78
0C08- 84 48 2B 3F 4B 88 10 00
0C10- 00 98 4B 3F 2B 48 84 00
0C18- 48 77 41 5D 41 77 78 3C
0C20- 00 98 CB 3F 6B C8 04 00
0C28- 00 10 88 6B 1F 2B CC 80
0C30- 5D 7F 08 1C 2A 49 08 01
0C38- 0F 08 78 40 6C 64 7C 64
0C40- 6C 78 48 7F 09 0F 7F 41
0C48- 49 41 7F 59 49 6B 49 4D
0C50- 7F 49 6B 49 7F 7F 49 7F
0C58- 49 7F 77 41 77 41 77 7F
0C60- 49 00 49 7F 22 55 49 55
0C68- 22 10 18 1C 18 10 41 63
0C70- 77 63 41 7F 3E 1C 08 00
0C78- 00 08 1C 3E 7F 08 1C 3E
*
```

Listing 4

```

0 REM *****
1 REM *
2 REM *          LOCOMOTIVE          *
3 REM *          R. C. VILE          *
4 REM *
5 REM *          COPYRIGHT (C) 1982  *
6 REM *          MICRO INK, INC.    *
7 REM *          CHELMSFORD, MA. 01824 *
8 REM *          ALL RIGHTS RESERVED *
9 REM *****
10 MUSIC=-10473: POKE 767,40: POKE 766,30: POKE 765,32:MOVE=500:SMOKE=
    22
11 GR : POKE -16302,0: COLOR=0
15 FOR I=40 TO 47: HLIN 0,39 AT I: NEXT I
21 POKE 2048,8: POKE 2049,8
32 POKE 36,20: POKE 37,24
33 CC= RND (15)+1
35 COLOR=CC
40 D=1
50 DX=-1:DY=0: GOSUB MOVE
55 GOTO 35
500 COL= PEEK (36):ROW= PEEK (37)
505 COL=COL+DX: IF COL<32 THEN 510: GOSUB 600:COL=0
510 IF COL>0 THEN 515: GOSUB 600:COL=32:CC= RND (15)+1
515 REM
530 POKE 36,COL: POKE 37,ROW
535 KEY=1
536 POKE 61,(3072+8*KEY)/256
537 POKE 60,(3072+8*KEY) MOD 256
540 CALL 2058
542 GOSUB 800
545 FOR TIME=1 TO 25: NEXT TIME
550 IF RND (25)=0 THEN GOSUB 700
555 COLOR=0
560 HLIN COL,COL+7 AT ROW+7
562 VLIN ROW,ROW+7 AT COL+7
570 RETURN
600 COLOR=0: FOR I=0 TO 7: HLIN COL,COL+7 AT ROW+I: NEXT I
610 RETURN
700 CALL MUSIC: REM *****REPLACE WITH RETURN IF YOU DO NOT HAVE THE PROGRAM
    MER'S AID ROM
705 POKE 766,100: FOR I=1 TO 50: NEXT I
710 CALL MUSIC: POKE 766,30: RETURN
800 PLOT COL+1,SMOKE
810 COLOR=0: PLOT COL+2,SMOKE+1
815 IF SMOKE=22 THEN PLOT COL+2,1
818 IF COL=32 THEN PLOT 2,SMOKE+1
820 SMOKE=SMOKE-1
830 IF SMOKE=0 THEN SMOKE=22
840 RETURN

```

Listing 5

```

0C00- FF FF FF 15 1F 7E 7C 78
0C08- FC BF FC 3C FF B9 F9 1F
0C10- 7D FD F0 78 70 FE F2 3E
0C18- 48 77 41 5D 41 77 78 3C
*
```

Numerical Data for Fireworks

```

0C00- FF FF FF 15 1F 15 F5 00
0C08- 00 00 08 00 00 00 00 00
0C10- 14 00 14 00 00 00 22 00
0C18- 00 00 22 00 41 00 00 00
0C20- 00 00 41 00 00 14 08 14
0C28- 00 00 00 22 14 00 14 22
0C30- 00 41 22 00 00 00 22 41
0C38- 00 22 14 08 14 22 00 41
0C40- 22 14 00 14 22 41 41 22
0C48- 14 08 14 22 41 00 00 00
0C50- 08 00 00 00 00 00 08 14
0C58- 08 00 00 00 08 00 22 00
0C60- 08 00 08 00 00 41 00 00
0C68- 08 00 00 08 1C 08 00 00
0C70- 00 08 08 36 08 08 00 08
0C78- 08 00 63 00 08 08 00 08
0C80- 08 3E 08 08 00 08 08 08
0C88- 77 08 08 08 08 08 08 7F
0C90- 08 08 08 12 1F 10 19 15
0C98- 12 11 15 0A 06 1F 04 17
OCA0- 15 09 1F 15 1D 19 05 03
OCA8- 0A 15 0A 17 15 1F 00 0A
OCB0- 00 10 1A 00 FF FF FF 0A
OCB8- 0A 0A FF FF FF 01 15 07
OCC0- FF FF FF 1F 05 1F 1F 15
OCC8- 0A 1F 11 11 1F 11 0E 1F
OCD0- 15 11 1F 05 01 1F 11 19
OCD8- 1F 04 1F 11 1F 11 18 11
OCE0- 1F 1F 06 19 1F 10 10 1F
OCE8- 02 1F 1F 0E 1F 1F 11 1F
OCF0- 1F 05 07 1F 11 17 1F 05
OCF8- 1A 17 15 1D 01 1F 01 1F
OD00- 10 1F 0F 10 0F 1F 08 1F
OD08- 1B 04 1B 03 1C 03 19 15
OD10- 13 FF FF FF FF FF FF 00
OD18- 11 1F FF FF FF FF FF FF
OD20- FF FF FF FF FF FF FF FF
*
```

5

TUTORIAL/REFERENCE

Apple Byte Table <i>Kim G. Woodward</i>	157
How Microsoft BASIC Works <i>Greg Paris</i>	164

Tutorial/Reference

Any computer can be made easier to program and use if there is information available that explains how it works, or concise and complete documentation. We had these points in mind when we prepared this chapter.

“Apple Byte Table” by Kim Woodward is a handy reference to byte-values within your system. If you ever need to read a monitor dump, this table will help you decipher the meaning of all those hexadecimal codes. You’ll want to keep this table around for other duties, such as converting hex to decimal, or hex to binary.

“How Microsoft BASIC Works” by Greg Paris explains how the various versions of Microsoft BASIC deal with variable storage. With this knowledge you are able to make a BASIC program more efficient through wise use of variables, or pass variables to assembly language subroutines, etc.

Apple Byte Table

by Kim G. Woodward

This useful reference table will simplify the task of decoding byte-values in the Apple's memory. For all numerical values, hex or decimal, each possible meaning is listed, ranging from ASCII to Applesoft token. If you ever tackle a hex dump, the Apple byte table will prove invaluable.

If you look at a single byte in the Apple or any other 8-bit microcomputer, it will mean different things at different times. Data and instructions are represented in the same manner in the computer: one byte may be data, an address, a token, or a command. I have put together a simple table which will be helpful no matter what the relationship is between the byte and your software. (Columns F, G, H, and I will be especially useful to the Apple owner.) The table is composed of 10 columns which represent:

- A. The equivalent decimal value of the byte (assuming the byte is not signed).
- B. The equivalent hex value of the byte.
- C. The equivalent binary value of the byte (very useful for assembly language masking).
- D. The value of the byte if it is looked at as the high byte of an address.
- E. The corresponding ASCII character for the byte (if there is one).
- F. The equivalent displayed screen character. (*I*-Inverse, *F*-Flashing, *N*-Normal.)
- G. The equivalent key to be pressed to get the byte. (If there is one, note all keys > \$7F. *C* after character means CTRL key held down.)

H. The corresponding Integer BASIC token for the byte. The Integer BASIC tokens can be found by keying:

```
> CALL -155      Go to monitor
* CA:00 10      Set program start
* 4C:14 10      Set program end
* 1000:13       Set length byte
* 1001:0A 00    Set line number
* 1003:         16 bytes of your choice
* 1013:01       End of line token
*              Return via CTRL-C
> LIST
```

I. The corresponding Applesoft BASIC token for the byte. The Applesoft tokens can be found by keying:

```
CALL -155      Go to monitor
* 67:01 08      Set program start
* AF:16 08      Set program end
* 801:16 08     Pointer to next line
* 803:0A 00     Set line number
* 805:         16 bytes of your choice
* 815:00        End of line token
* 816:00 00 00  End of program pointer
* 0G           Back to BASIC
LIST
```

J. The corresponding 6502 machine language opcode.

Let's note some of the subtleties in the table's usage. First of all, if a particular pattern for a mask operation is needed, then it is a simple matter of looking down the table until the correct binary (column 3) pattern is found. Then on the same line, read the decimal equivalent for a POKE command, or the hex equivalent for assembly language use. In a similar manner you can do the following:

A. Decimal to hexadecimal conversion — scan the table in column 4 to find the highest number not exceeding the decimal number. If the number is negative (such as addresses in Integer BASIC larger than 32767), add 65536 before the conversion. Write down the hex value and subtract the decimal number just found. Then find the decimal remainder in the table and write down the hex value for it. The first hex value is the high byte and the second is the low byte. For example, find the hex equivalent of -936 (clear).

-936 + 65536 = 64600 : the number to find. Find 64512 (\$FC) : highest number less than 64600 -64512 = 88 : find difference. Find 88 (\$58) : remainder. Value of -936 decimal is \$FC58.

- B. Hexadecimal to decimal conversion — separate the hex number into two bytes. Scan the table for the value of the high order byte in column 4. Then scan the table for the value of the low order byte in column 1, add the two numbers together and get the result. For negative addresses ($> \$7FFF$) simply subtract 65536 from the number.
- C. Relative addressing — the formula for relative addressing on the 6502 is: address of branch to address - address of branch inst. - 2. For example, to branch from location $\$345$ to $\$313$ you could find the decimal equivalent of $\$345$ as per (A) above, 837, and of $\$313$, 787. Thus $787 - 837 - 2$ is -52 . Add 256 to -52 giving 204. Look up 204 in the table as $\$CC$. $\$CC$ is then the relative address offset.

Columns F and G in the table can be found in the *Apple Reference Handbook* by Apple Computer, Inc.

The Apple Byte Table

Dec	Hx	Binary	High	Asc	Sc	Ky	Int Bs	Aps Bs	6502:
000	00	00000000	0	NUL	@I		HIMEM:	NUL	BRK
001	01	00000001	256	SOH	AI		EOS	SOH	ORAI X
002	02	00000010	512	STX	BI		-	STX	
003	03	00000011	768	ETX	CI		!	ETX	
004	04	00000100	1024	EOT	DI		LOAD	EOT	
005	05	00000101	1280	ENQ	EI		SAVE	ENQ	ORAZ
006	06	00000110	1536	ACK	FI		CON	ACK	ASLZ
007	07	00000111	1792	BEL	GI		RUN	BEL	
008	08	00001000	2048	BS	HI		RUN	BS	PHP
009	09	00001001	2304	HT	II		DEL	HT	ORAIM
010	0A	00001010	2560	LF	JI	,	,	LF	ASLA
011	0B	00001011	2816	VT	KI		NEW	VT	
012	0C	00001100	3072	FF	LI		CLR	FF	
013	0D	00001101	3328	CR	MI		AUTO	CR	ORA
014	0E	00001110	3584	SO	NI	,	,	SO	ASL
015	0F	00001111	3840	SI	OI		MAN	SI	
016	10	00010000	4096	DLE	PI		HIMEM:	DLE	BPL
017	11	00010001	4352	DC1	QI		LOMEM:	DC1	ORAI X
018	12	00010010	4608	DC2	RI	+	+	DC2	
019	13	00010011	4864	DC3	SI	-	-	DC3	
020	14	00010100	5120	DC4	TI	*	*	DC4	
021	15	00010101	5376	NAK	UI	/	/	NAK	ORAZ X
022	16	00010110	5632	SYN	VI	=	=	SYN	ASLZ X
023	17	00010111	5888	ETB	WI	#	#	ETB	
024	18	00011000	6144	CAN	XI	>=	>=	CAN	CLC
025	19	00011001	6400	EM	YI	>	>	EM	ORAY
026	1A	00011010	6656	SUB	ZI	<=	<=	SUB	
027	1B	00011011	6912	ESC	[I	<>	<>	ESC	
028	1C	00011100	7168	FS	\I	<	<	FS	
029	1D	00011101	7424	GS]I	AND	AND	GS	ORAX
030	1E	00011110	7680	RS	^I	OR	OR	RS	ASLX
031	1F	00011111	7936	US	_I	MOD	MOD	US	
032	20	00100000	8192	SPC	I	^	^	SPC	JSR
033	21	00100001	8448	!	!I	+	+	!	ANDIX
034	22	00100010	8704	"	"I	(("	
035	23	00100011	8960	#	#I	,	,	#	
036	24	00100100	9216	\$	\$I	THEN	THEN	\$	BITZ
037	25	00100101	9472	%	%I	THEN	THEN	%	ANDZ
038	26	00100110	9728	&	&I	,	,	&	ROLZ
039	27	00100111	9984	'	'I	,	,	'	
040	28	00101000	10240	((I	"	"	(PLP
041	29	00101001	10496))I	"	")	ANDIM
042	2A	00101010	10752	*	*I	((*	ROLA
043	2B	00101011	11008	+	+I	!	!	+	
044	2C	00101100	11264	,	,I	!	!	,	BIT
045	2D	00101101	11520	-	-I	((-	AND
046	2E	00101110	11776	.	.I	PEEK	PEEK	.	ROL
047	2F	00101111	12032	/	/I	RND	RND	/	
048	30	00110000	12288	0	0I	SGN	SGN	0	BMI
049	31	00110001	12544	1	1I	ABS	ABS	1	ANDI Y
050	32	00110010	12800	2	2I	PDL	PDL	2	
051	33	00110011	13056	3	3I	RNDX	RNDX	3	
052	34	00110100	13312	4	4I	((4	
053	35	00110101	13568	5	5I	+	+	5	ANDZ X
054	36	00110110	13824	6	6I	-	-	6	ROLZ X
055	37	00110111	14080	7	7I	NOT	NOT	7	
056	38	00111000	14336	8	8I	((8	SEC
057	39	00111001	14592	9	9I	=	=	9	ANDY
058	3A	00111010	14848	:	:I	#	#	:	
059	3B	00111011	15104	;	;I	LEN(LEN(;	
060	3C	00111100	15360	<	<I	ASC(ASC(<	
061	3D	00111101	15616	=	=I	SCRN(SCRN(=	ANDX
062	3E	00111110	15872	>	>I	,	,	>	ROLX
063	3F	00111111	16128	?	?I	((?	
064	40	01000000	16384	@	@F	*	*	@	RTI

Dec	Hx	Binary	High	Asc	Sc	Ky	Int Bs	Aps Bs	6502
065	41	01000001	16640	A	AF		\$	A	EORIX
066	42	01000010	16896	B	BF		(B	
067	43	01000011	17152	C	CF		,	C	
068	44	01000100	17408	D	DF		;	D	
069	45	01000101	17664	E	EF		;	E	EORZ
070	46	01000110	17920	F	FF		;	F	LSRZ
071	47	01000111	18176	G	GF		;	G	
072	48	01001000	18432	H	HF		,	H	PHA
073	49	01001001	18688	I	IF		,	I	EORIM
074	4A	01001010	18944	J	JF		,	J	LSRA
075	4B	01001011	19200	K	KF		TEXT	K	
076	4C	01001100	19456	L	LF		GR	L	JMP
077	4D	01001101	19712	M	MF		CALL	M	EOR
078	4E	01001110	19968	N	NF		DIM	N	LSR
079	4F	01001111	20224	O	OF		DIM	O	
080	50	01010000	20480	P	PF		TAB	P	BVC
081	51	01010001	20736	Q	QF		END	Q	EORIY
082	52	01010010	20992	R	RF		INPUT	R	
083	53	01010011	21248	S	SF		INPUT	S	
084	54	01010100	21504	T	TF		INPUT	T	
085	55	01010101	21760	U	UF		FOR	U	EORZX
086	56	01010110	22016	V	VF		=	V	LSRZX
087	57	01010111	22272	W	WF		TO	W	
088	58	01011000	22528	X	XF		STEP	X	CLI
089	59	01011001	22784	Y	YF		NEXT	Y	EORY
090	5A	01011010	23040	Z	ZF		,	Z	
091	5B	01011011	23296	[CF		RETURN	[
092	5C	01011100	23552	\	CF		GOSUB	\	
093	5D	01011101	23808]	CF		REM]	EORX
094	5E	01011110	24064	^	CF		LET	^	LSRX
095	5F	01011111	24320	_	CF		GOTO	_	
096	60	01100000	24576	'	F		IF		RTS
097	61	01100001	24832	a	!F		PRINT		ADCIX
098	62	01100010	25088	b	"F		PRINT		
099	63	01100011	25344	c	#F		PRINT		
100	64	01100100	25600	d	\$F		POKE		
101	65	01100101	25856	e	%F		,		ADCZ
102	66	01100110	26112	f	&F		COLOR=		RORZ
103	67	01100111	26368	g	'F		PLOT		
104	68	01101000	26624	h	(F		,		PLA
105	69	01101001	26880	i)F		HLIN		ADCIM
106	6A	01101010	27136	j	*F		,		RORA
107	6B	01101011	27392	k	+F		AT		
108	6C	01101100	27648	l	,F		VLIN		JMPI
109	6D	01101101	27904	m	-F		,		ADC
110	6E	01101110	28160	n	.F		AT		ROR
111	6F	01101111	28416	o	/F		VTAB		
112	70	01110000	28672	p	OF		=		BVS
113	71	01110001	28928	q	1F		=		ADCIIY
114	72	01110010	29184	r	2F)		
115	73	01110011	29440	s	3F)		
116	74	01110100	29696	t	4F		LIST		
117	75	01110101	29952	u	5F		,		ADCZX
118	76	01110110	30208	v	6F		LIST		RORZX
119	77	01110111	30464	w	7F		POP		
120	78	01111000	30720	x	8F		NODSP		SEI
121	79	01111001	30976	y	9F		NODSP		ADCY
122	7A	01111010	31232	z	:F		NOTRACE		
123	7B	01111011	31488	{	:F		DSP		
124	7C	01111100	31744		<FF		DSP		
125	7D	01111101	32000	}	=F		TRACE		ADCX
126	7E	01111110	32256	~	>F		PR#		RORX
127	7F	01111111	32512	RUB	?F		IN#		
128	80	10000000	32768		@N		NUL	END	
129	81	10000001	33024		AN	AC	SOH	FOR	STAI X
130	82	10000010	33280		BN	BC	STX	NEXT	
131	83	10000011	33536		CN	CC	ETX	DATA	
132	84	10000100	33792		DN	DC	EOT	INPUT	STYZ
133	85	10000101	34048		EN	EC	ENQ	DEL	STAZ
134	86	10000110	34304		FN	FC	ACK	DIM	STXZ
135	87	10000111	34560		GN	GC	BEL	READ	

Dec	Hx	Binary	High	Asc	Sc	Ky	Int Bs	Aps Bs	6502
136	88	10001000	34816		HN	HC	BS	GR	DEY
137	89	10001001	35072		IN	IC	HT	TEXT	
138	8A	10001010	35328		JN	JC	LF	PR#	TXA
139	8B	10001011	35584		KN	KC	VT	IN#	
140	8C	10001100	35840		LN	LC	FF	CALL	STY
141	8D	10001101	36096		MN	MC	CR	PLOT	STA
142	8E	10001110	36352		NN	NC	SD	HLIN	STX
143	8F	10001111	36608		ON	OC	SI	VLIN	
144	90	10010000	36864		PN	PC	DLE	HGR2	BCC
145	91	10010001	37120		QN	QC	DC1	HGR	STAIY
146	92	10010010	37376		RN	RC	DC2	HCOLOR=	
147	93	10010011	37632		SN	SC	DC3	HPL0T	
148	94	10010100	37888		TN	TC	DC4	DRAW	STYZX
149	95	10010101	38144		UN	UC	NAK	XDRAW	STAZX
150	96	10010110	38400		VN	VC	SYN	HTAB	STXZY
151	97	10010111	38656		WN	WC	ETB	HOME	
152	98	10011000	38912		XN	XC	CAN	ROT=	TYA
153	99	10011001	39168		YN	YC	EM	SCALE=	STAY
154	9A	10011010	39424		ZN	ZC	SUB	SHLOAD	TXS
155	9B	10011011	39680		[N	ESC	ESC	TRACE	
156	9C	10011100	39936		\N		FSS	NOTRACE	
157	9D	10011101	40192		[N	MCU	GS	NORMAL	STAX
158	9E	10011110	40448		^N	^C	RS	INVERSE	
159	9F	10011111	40704		_N		US	FLASH	
160	A0	10100000	40960		N	SPC	SPC	COLOR=	LDYIM
161	A1	10100001	41216		!N	!	!	POP	LDAIX
162	A2	10100010	41472		"N	"	"	VTAB	LDXIM
163	A3	10100011	41728		#N	#	#	HIMEM1	
164	A4	10100100	41984		\$N	\$	\$	LOMEM1	LDYZ
165	A5	10100101	42240		%N	%	%	ONERR	LDAZ
166	A6	10100110	42496		&N	&	&	RESUME	LDXZ
167	A7	10100111	42752		'N	'	'	RECALL	
168	AB	10101000	43008		(N	((STORE	TAY
169	A9	10101001	43264)N))	SPEED=	LDAIM
170	AA	10101010	43520		*N	*	*	LET	TAX
171	AB	10101011	43776		+N	+	+	GOTO	
172	AC	10101100	44032		,N	,	,	RUN	LDY
173	AD	10101101	44288		-N	-	-	IF	LDA
174	AE	10101110	44544		.N	.	.	RESTORE	LDX
175	AF	10101111	44800		/N	/	/	&	
176	B0	10110000	45056		0N	0	0	GOSUB	BCS
177	B1	10110001	45312		1N	1	1	RETURN	LDAIY
178	B2	10110010	45568		2N	2	2	REM	
179	B3	10110011	45824		3N	3	3	STOP	
180	B4	10110100	46080		4N	4	4	ON	LDYZX
181	B5	10110101	46336		5N	5	5	WAIT	LDAZX
182	B6	10110110	46592		6N	6	6	LOAD	LDXZY
183	B7	10110111	46848		7N	7	7	SAVE	
184	B8	10111000	47104		8N	8	8	DEF	CLV
185	B9	10111001	47360		9N	9	9	POKE	LDAY
186	BA	10111010	47616		:N	:	:	PRINT	TSX
187	BB	10111011	47872		;N	;	;	CONT	
188	BC	10111100	48128		<N	<	<	LIST	LDYX
189	BD	10111101	48384		=N	=	=	CLEAR	LDAZ
190	BE	10111110	48640		>N	>	>	GET	LDYX
191	BF	10111111	48896		?N	?	?	NEW	
192	C0	11000000	49152		@N	@	@	TAB(CPYIM
193	C1	11000001	49408		AN	A	A	TO	CMPIX
194	C2	11000010	49664		BN	B	B	FN	
195	C3	11000011	49920		CN	C	C	SPC(
196	C4	11000100	50176		DN	D	D	THEN	CPYZ
197	C5	11000101	50432		EN	E	E	AT	CMYZ
198	C6	11000110	50688		FN	F	F	NOT	DECZ
199	C7	11000111	50944		GN	G	G	STEP	
200	C8	11001000	51200		HN	H	H	+	INY
201	C9	11001001	51456		IN	I	I	-	CMPIY
202	CA	11001010	51712		JN	J	J	*	DEX
203	CB	11001011	51968		KN	K	K	/	
204	CC	11001100	52224		LN	L	L	^	CPY
205	CD	11001101	52480		MN	M	M	AND	CMP
206	CE	11001110	52736		NN	N	N	OR	DEC
207	CF	11001111	52992		ON	O	O	>	
208	DO	11010000	53248		PN	P	P	=	BNE

Dec	Hx	Binary	High	Asc	Sc	Ky	Int Bs	Aps Bs	6502
209	D1	11010001	53504		QN	Q	Q	<	CMPIY
210	D2	11010010	53760		RN	R	R	SGN	
211	D3	11010011	54016		SN	S	S	INT	
212	D4	11010100	54272		TN	T	T	ABS	
213	D5	11010101	54528		UN	U	U	USR	CMFZX
214	D6	11010110	54784		VN	V	V	FRE	DECZX
215	D7	11010111	55040		WN	W	W	SCRN (
216	D8	11011000	55296		XN	X	X	PDL	CLD
217	D9	11011001	55552		YN	Y	Y	POS	CMFY
218	DA	11011010	55808		ZN	Z	Z	SGR	
219	DB	11011011	56064		[N	[[RND	
220	DC	11011100	56320		\N	\	\	LOG	
221	DD	11011101	56576]N	MCU]	EXP	CMFZX
222	DE	11011110	56832		^N	^	^	COS	DECX
223	DF	11011111	57088		_N	_	_	SIN	
224	E0	11100000	57344		N			TAN	CPXIM
225	E1	11100001	57600		!N			ATN	SBCIX
226	E2	11100010	57856		"N			PEEK	
227	E3	11100011	58112		#N			LEN	
228	E4	11100100	58368		\$N			STR*	CPXZ
229	E5	11100101	58624		%N			VAL	SBCZ
230	E6	11100110	58880		&N			ASC	INCZ
231	E7	11100111	59136		'N			CHR*	
232	E8	11101000	59392		(N			LEFT*	INX
233	E9	11101001	59648)N			RIGHT*	SBCIM
234	EA	11101010	59904		*N			MID*	NOP
235	EB	11101011	60160		+N				
236	EC	11101100	60416		,N			SYNTAX	CPX
237	ED	11101101	60672		-N			RWD GSB	SBC
238	EE	11101110	60928		.N			OUT DTA	INC
239	EF	11101111	61184		/N			ILL QNT	
240	F0	11110000	61440		ON			OVERFLW	BEG
241	F1	11110001	61696		1N			OUT MEM	SBCIY
242	F2	11110010	61952		2N			UNF STM	
243	F3	11110011	62208		3N			BD SUBS	
244	F4	11110100	62464		4N			RDM ARY	
245	F5	11110101	62720		5N			DIV ZER	SBCZX
246	F6	11110110	62976		6N			ILL DIR	INCZX
247	F7	11110111	63232		7N			TYP MIS	
248	F8	11111000	63488		8N			STR LNG	SED
249	F9	11111001	63744		9N			FRM CPX	SBCY
250	FA	11111010	64000		:N			CANTCNT	
251	FB	11111011	64256		;N			UNDFNC	
252	FC	11111100	64512		<N			ERROR	
253	FD	11111101	64768		=N			(SBCX
254	FE	11111110	65024		>N			(INCX
255	FF	11111111	65280		?N			(

How Microsoft BASIC Works

by Greg Paris

What is a variable? How are variables manipulated? This article gives the answers to both of these questions and discusses the similarity of FNx definitions to variables as well.

All computer languages are, to some extent, symbolic in nature. This means that addresses, constants, and variables may be used throughout a program and manipulated by their labels, instead of using absolute or true values. Although the use of symbols is often merely convenient — as in assembler texts — in many circumstances the concept permits manipulations which otherwise would be impossible. Algebraic variables in BASIC or FORTRAN are just one important case. For these reasons, how a computer language defines and manipulates symbols is fundamental to the structure and operation of whatever interfaces between the user and the opcodes — an interpreter, compiler, etc.

The varieties of symbol types allowed in any language determine, to a great extent, the power of that language to solve certain programming problems. The inherent accuracy of mathematical calculations is another example where the format of variable storage is critical.

For these reasons, a logical first step in dissecting the operation of the BASIC interpreter is to find out how it defines its symbols, and how it stores them.

This article is organized as follows. First, I offer a few definitions. This will level out most readers' backgrounds, and obviously may be skipped if you know the jargon. Next I describe the actual formats of both numeric and string variables. Then I discuss how BASIC uses RAM. Finally, I combine all of the above to describe variable *storage* formats, and explain their coding.

Definitions

I caution the more advanced reader that I am not a software development engineer, and may not use the approved industry-standard terminology.

Legal Variable Name: The BASIC manual defines a legal variable name to be "any alphabetic character, and [it] may be followed by any alphanumeric character... Any alphanumeric characters after the first two are ignored." In addition, one cannot embed reserved words into the variable name (A\$ and AAAAAAA are legal variable names; %A is not, and neither is AGOTO).

Variable: To the interpreter, a variable is anything that is not an array (no joke!). Any time you need to refer to only one number, or one string, or one whatever, it will be called a variable. For example, X1 is a floating-point (or FP) variable, X1% is an integer variable, and X1\$ is a string variable. They are stored in different ways internally so the interpreter cannot be confused by these three identical variable symbols. You may be confused however, so use caution in such cases.

Array: An array is any group of variables which is referred to by a common legal variable name, followed by a list of subscripts — also called indices. The BASIC manual sometimes refers to arrays as "matrices." An array may contain either integer or FP numeric data or strings, but no more than one type per array. You are, in theory, allowed 255 subscripts; the real restriction is the line length which limits you to twenty or so. For example, DIM X1(2) allots space for a singly subscripted FP array, and has room for 3 numbers — X1(0), X1(1), and X1(2). Further, DIM X1%(20) allots space for an array of 21 integer variables, and DIM X1\$(10,3) partitions space for a doubly subscripted array of 44 $[(10 + 1) \times (3 + 1)]$ different strings. (A technical note: if an array is not dimensioned before it is used, the interpreter will automatically execute a DIM command and thus assign each subscript the default value of 10.)

Header: I define a header as any information about a variable (how it is stored or referred to) that is stored along with the data to which it refers. For example, if the interpreter requires information about an array, including its size, how many subscripts, and the values of those subscripts, then the interpreter will group all this information, along with the variable name, into a header — the small block of "data" which immediately precedes the real data in the array. A header may be as short and simple as the 2 bytes of an encoded variable name, or as detailed as the example just given.

.WOR Address Format: When a 16-bit address is to be stored in an 8-bit machine, it can be stored first byte (MSB) first, second byte (LSB) second, or in the reverse order. In assembler notation, the MSB-first arrangement is often referred to as ".DBY" (for "Double BYte"), whereas the reversed order — LSB-first — is called ".WOR" order (for "WORd"). Almost all addresses handled by the BASIC interpreter are stored in .WOR format, including those that may be embedded in headers.

Numeric Variables

There are two types of numeric data allowed in BASIC: integer and floating-point (FP). An integer number is stored in two bytes, and can represent any integer between +32,767 and -32,768. An FP number is stored in 5 bytes (4 bytes on

OSI) and can represent numbers between $\pm 1.7 \times 10^{38}$ and $\pm 2.94 \times 10^{-39}$, and zero. This format for FP numbers allows at least 9 decimal digit accuracy at all times.

Since FP arithmetic as done by the BASIC interpreter is not germane, I will not detail its function in this article. Suffice it to say that there exists, in zero-page RAM, temporary storage areas for two FP numbers. The one most used is the floating-point accumulator (or FPA) and is located at the addresses shown in figure 1-A. The FPA is five to seven bytes long — the second byte of the FPA contains the sign of the mantissa, which is incorporated into the leftmost bit (MSB) of the mantissa whenever a number is removed from the FPA. (The use of this bit for the sign need not confuse you, since in the FPA this bit is *defined* as being set, unless the number equals zero. Therefore, if it will *always* be 1, then it can be ignored during storage and used for another purpose, namely, to store the sign of the mantissa compactly.) In addition, there is a byte (see figure 1-A) which actually extends the FPA mantissa by 8 bits. It is used internally in all arithmetic operations, but is rounded off and stripped whenever a variable is removed from the FPA. The first byte of the FPA is the exponent of the number plus \$80. If the number equals zero, then this byte is zero.

Both types of variables, if referred to before being assigned a specific numeric value (i.e., if you use a previously undefined variable), will be filled with 0's — hence, the default value in each case is zero.

Figure 1-A: Locations of Floating-Point Accumulators.

Computer:	AIM 65	Applesoft	OSI (BASIC- in-ROM)	Old PET (1.0)	New PET (2.0, 4.0)
Length of FPA	6 bytes	7 bytes	5 bytes	6 bytes	6 bytes
Address of FPA	\$00A9- \$00AE	\$009D- \$00A3	\$00AC- \$00B0	\$00B0- \$00B5	\$005E- \$0063
FPA extension	\$00B8	(\$00A3)	\$00B2	\$00B7	\$0065

String Variables

The "value" of a string variable, and the information stored in a string variable (or array) in RAM, are two different things. The two items actually stored in the "variable" or "array" are a pointer (or a list of pointers) in .WOR format to the start of the string, and the length of the string. The string may be embedded in a program line, or stored in "top free space" (high RAM).

If the string is empty ("null"), then the byte for string length is set to zero, and although it will then be ignored, both bytes of the pointer are zeroed. The size of any string is limited to 255 characters because a single byte is used to indicate its length.

User Functions

DEF and FNx are BASIC program statements which allow a user to define a unique function. Each FNx is labeled by a legal variable name, and this is why I discuss this statement in an article on variables. As detailed later, the BASIC interpreter stores a reference to each function definition in a complex header, filed under the variable name which is assigned to it by the user.

How BASIC Uses RAM

A memory map of how BASIC partitions space for its various needs is shown in figure 1-B. "Top free space" may be a new term to some readers. When BASIC is commanded to operate on strings, it designates an area in unused memory as work space (from \$UNUN to \$TTTT - 1), and then stores the result of any operation in "top free space" (from \$TTTT to \$NONO - 1).

Also listed in figure 1-B are the zero-page locations which are reserved by BASIC to store pointers to various addresses which are used frequently. These pointers are initialized upon entry into BASIC, and are updated any time the program is changed or run. All pointers are stored in .WOR format.

Figure 1-B: BASIC Utility Pointers.

Computer:	AIM 65	Apple	OSI (BASIC- in-ROM)	Old PET	New PET
Address of pointer to:					
Start of BASIC program (address:)	\$0073 (\$0212)	\$0067 (\$0801)	\$0079 (\$0301)	\$007A (\$0402)	\$0028 (\$0402)
Start of variable storage (\$PPPP)	\$0075	\$0069	\$007B	\$007C	\$002A
Start of array storage (\$RRRR)	\$0077	\$006B	\$007D	\$007E	\$002C
Start of free space (\$UNUN)	\$0079	\$006D	\$007F	\$0080	\$002E
Top (end) of free space (\$TTTT)	\$007B	\$006F	\$0081	\$0082	\$0030
Top of memory (\$NONO)	\$007F	\$004C	\$0085	\$0086	\$0034

How Variable Names are Encoded

BASIC reserves 2 bytes for the variable name (symbol). However, since the same name could refer either to an integer, FP variable, or a string, it must distinguish between them. It does this by setting or clearing, in various combinations, the otherwise unused leftmost bit (MSB) of each of the two bytes in the name. All four possible permutations are used. The interpreter performs this encoding during a RUN whenever a new variable name is encountered, and uses the format described in table 1. If a variable name is only a single character, then the second character space allotted to it is filled with 0's, except for the MSB, which is set or cleared as needed.

Storage Formats

Most of the details of variable format and variable name encoding have been described. All that remains is to put the information together and describe what is actually found in memory from \$PPPP to \$UNUN - 1.

Variables are stored together, but separate from the arrays. However, integer numeric, FP numeric, string, and FNx definition variables are all intermixed. Arrays are stored in the next higher allocated RAM, and are also intermixed. In both cases, the jumbled order is actually a function of when they are defined during the RUNning of a program. Each variable or array that is interpreted is assigned a space in the order in which it is encountered, with the variables and the arrays each shuttled off to their respective spaces.

There is a reason for separating variables from arrays. Each item stored as a variable takes up exactly 7 bytes. This makes searching for variables very easy, as the interpreter's variable pointer need only increment by 7 bytes to look for the next variable. Since arrays can vary greatly in size, this technique is not applicable, and scanning for individual array entries is somewhat more time consuming.

Table 1: Format for encoding different types of variable names.

If the legal variable name is AC, then:

if the variable is	then the symbol is encoded as these two bytes:
a floating point numeric (no suffix)	\$41, \$43 (MSB each byte clear)
an integer numeric (suffix = %)	\$C1, \$C3 (MSB each byte set)
a string (suffix = \$)	\$41, \$C3 (MSB first byte clear, MSB second byte set)
an FNx definition variable	\$C1, \$43 (MSB first byte set, MSB second byte clear)

Each time the program begins RUNning, it executes a CLEAR instruction, which erases any reference to any variables and arrays which may have previously been defined. This CLEAR instruction sets the pointers located at \$0075, \$0077, and \$0079 (on the AIM) to the same value — the address of the last byte of program storage, plus one. Similarly, the pointer at \$007B ("top free space") is set to equal the address in \$007F (top usable memory + 1).

The headers for variables and arrays, and the formats in which they are stored in RAM, are shown in figure 2.

Figure 2: Variable and Array Storage Formats

VARIABLES:

Floating Point Numeric

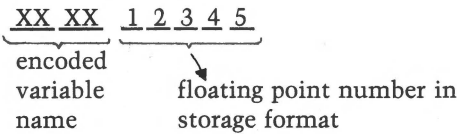

Integer Numeric

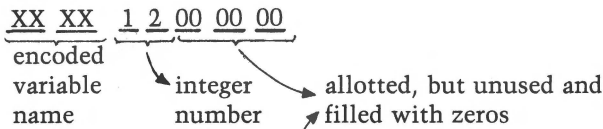

String Header

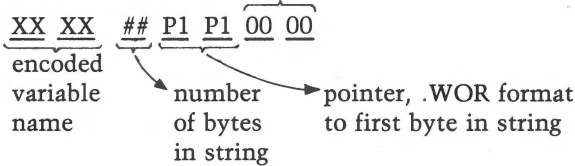

FNx Header

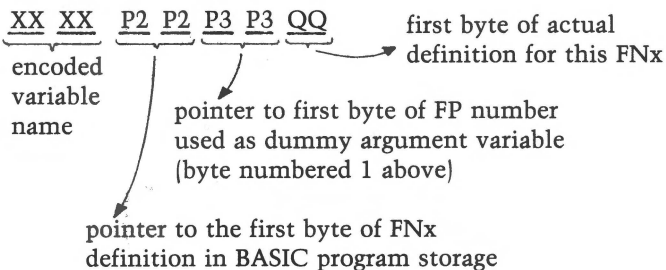

ARRAYS:

Floating Point Numeric

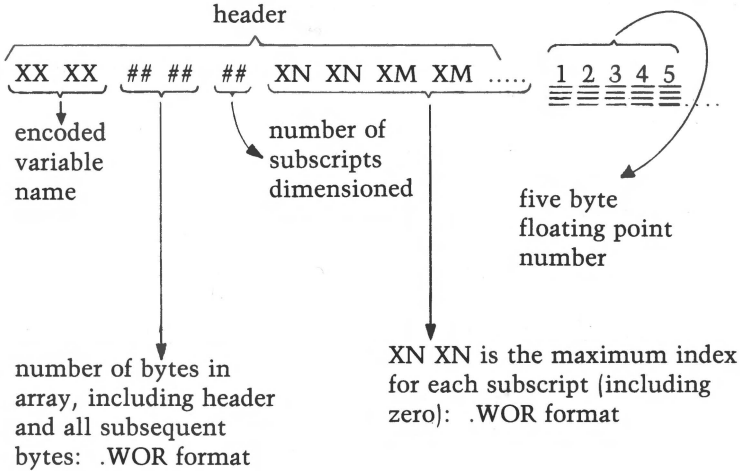

two byte integer number
(.DBY storage format)

Integer Numeric

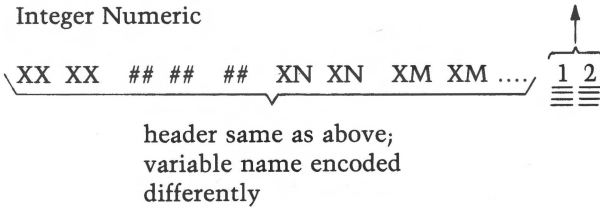

String

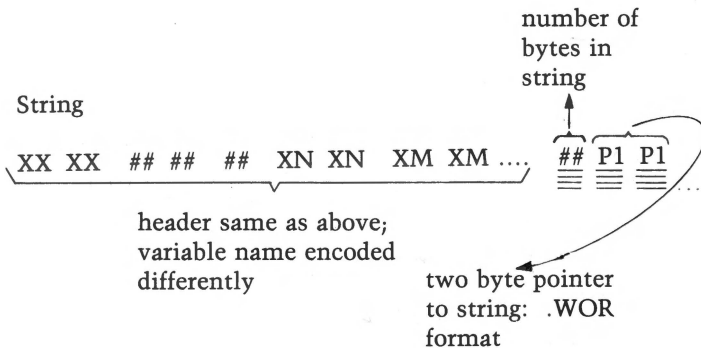

The definition of a header should be clearer now. In both types of numeric variables, the header is simply the 2 bytes of the encoded variable name. More complicated arrangements are seen in the FNx header and the various array headers.

Variables: For an FP variable, all 7 bytes are utilized. The last 5 bytes represent the FP number, in RAM storage form as described above.

An integer variable only uses 4 of the 7 bytes allotted to it. Use of integer variables in your program therefore wastes some space, but could save time during interpretation.

The string "variable" has a 5-byte header, made to fill 7 bytes by tacking a bunch of zeros on the end.

The FNx header is very interesting. It is filed as a variable because it is defined with a variable name. Any legal variable name may be used as its label. In addition, any legal variable name may be used as the dummy argument variable, even one used elsewhere in the program, because before the interpreter evaluates an FNx statement, it saves the value which was originally stored in the dummy variable on the stack. If the dummy variable is a new variable, it is automatically created, allotted 7 bytes of space after the FNx header, and appropriately labeled as an FP variable. The FNx header is set up whenever a DEF FNx is performed. If this particular FNx is later redefined, only the original header is changed. The last byte in the header might not be used by the interpreter; it seems to be there only to clear the stack completely during the DEF FNx operation.

Arrays: Not only do arrays have longer headers, but they also utilize space more efficiently. There is no minimum allotment of space, and consequently, no filler bytes are necessary. FNx arrays are not supported in this version of BASIC.

The headers for each type of array are essentially identical in format and content. The first two bytes are the encoded array name (see table 1). The next pair of bytes is a 16-bit number (.WOR format), the total number of bytes in the array. This includes the header with all its subscripts spelled out, and all the space allotted for the variables or string pointers. The fifth byte represents the number of subscripts used. The remainder of the header is a list of subscripts — a series of 16-bit numbers in .WOR format, one for each subscript — in an order that is the REVERSE of the listed order in the DIM statement.

The actual storage format of the array contents is much the same as for a single variable. Each member of an FP array is allotted five bytes for storage, and each member of an integer array is allotted two bytes. Therefore, in contrast to an integer variable, using integer *arrays* not only saves interpreting time but also a tremendous amount of space as well. Each entry in a string array is allotted three bytes, as before.

Within the array, individual members are ordered in straightforward fashion, but not as simply as you'd expect. Just as in the array header, the individual members of an array are in a "reversed" ascending sequence. For example, if the

Figure 3

```

A.
10 DIM AA(2),B%(2,3)
20 AA=2:B%=17
30 DEF FNQ(X)=X*AA
40 C=5.7207
50 D$="A STRING"
60 DIM C(2)
70 F%=-24
80 E2$="IS NOT "+D$
90 STOP

```

B.

```

<M>=0073 12 02 BASIC PROGRAM STARTS AT $0212
< > 0075 98 02 VARIABLES START AT $0298
< > 0077 D0 02 ARRAYS START AT $02D0
< > 0079 1D 03 FREE SPACE STARTS AS $031D
< > 007B F1 0F FREE SPACE ENDS AT $0FF1
< > 007F 00 10 TOP OF MEMORY IS $1000

```

C.

```

<M>=0212 26 02 NEXT LINE IS AT $0226
< > 0214 0A 00 THIS IS LINE 10
< > 0216 85 20 'DIM' TOKEN, SPACE
< > 0218 41 41 'AA'
< > 021A 28 32 '(2'
< > 021C 29 2C ')',
< > 021E 42 25 'B%'
< > 0220 28 32 '(2'
< > 0222 2C 33 ',3'
< > 0224 29 00 ')', END OF LINE
< > 0226 35 02 NEXT LINE IS AT $0235
< > 0228 14 00 THIS IS LINE 20
< > 022A 41 41 'AA'
< > 022C AC 32 '=' TOKEN, '2'
< > 022E 3A 42 ':B'
< > 0230 25 AC '%', '=' TOKEN
< > 0232 31 37 '17'
< > 0234 00 END OF LINE
< > 0235 46 02 NEXT LINE IS AT $0246
< > 0237 1E 00 THIS IS LINE 30
< > 0239 95 20 'DEF' TOKEN, SPACE
< > 023B 9F 51 'FN' TOKEN, 'Q'
< > 023D 28 58 '(X'
< > 023F 29 AC ')', '=' TOKEN
< > 0241 58 A6 'X', '*' TOKEN
< > 0243 41 41 'AA'
< > 0245 00 END OF LINE
< > 0246 53 02 NEXT LINE IS AT $0253
< > 0248 28 00 THIS IS LINE 40
< > 024A 43 AC 'C', '=' TOKEN
< > 024C 35 2E '5.'
< > 024E 37 32 '72'
< > 0250 30 37 '07'
< > 0252 00 END OF LINE
< > 0253 65 02 NEXT LINE IS AT $0265
< > 0255 32 00 THIS IS LINE 50
< > 0257 44 24 'D$'
< > 0259 AC 22 '=' TOKEN, ''
< > 025B 41 20 'A '
< > 025D 53 54 'ST'
< > 025F 52 49 'RI'
< > 0261 4E 47 'NG'
< > 0263 22 00 ''', END OF LINE

```

D.

```

<M>=0298 41 41  FP VARIABLE 'AA'
< > 029A 82 00  VALUE IS 2
< > 029C 00 00
< > 029E 00
< > 029F C2 80  INTEGER VARIABLE 'B'
< > 02A1 00 11  VALUE IS 17
< > 02A3 00 00
< > 02A5 00
< > 02A6 D1 00  FN 'Q'
< > 02A8 41 02  DEFINED AT $0241
< > 02AA AF 02  DUMMY VARIABLE VALUE AT $02AF
< > 02AC 58
< > 02AD 58 00  FP VARIABLE 'X'
< > 02AF 00 00  VALUE IS 0
< > 02B1 00 00
< > 02B3 00
< > 02B4 43 00  FP VARIABLE 'C'
< > 02B6 83 37  VALUE IS 5.7207
< > 02B8 0F F9
< > 02BA 73
< > 02BB 44 80  STRING VARIABLE 'D' (D$)
< > 02BD 08      8 BYTES OF DATA
< > 02BE 5B 02  AT $025B
< > 02C0 00 00
< > 02C2 C6 80  INTEGER VARIABLE 'F' (F%)
< > 02C4 FF E8  VALUE IS -24
< > 02C6 00 00
< > 02C8 00
< > 02C9 45 B2  STRING VARIABLE '2' (E2$)
< > 02CB 0F      15 BYTES OF DATA
< > 02CC F1 0F  AT $0FF1
< > 02CE 00 00

< > 02D0 41 41  FP ARRAY 'AA'
< > 02D2 16 00  USES 22 BYTES
< > 02D4 01      1 SUBSCRIPT
< > 02D5 00 03  SUBSCRIPT = 2
< > 02D7 00 00  ARRAY ELEMENTS ARE ALL 0

< > 02E6 C2 80  INTEGER ARRAY 'B' (B%)
< > 02E8 21 00  USES 33 BYTES
< > 02EA 02      2 SUBSCRIPTS
< > 02EB 00 04  SUBSCRIPT 2 = 3
< > 02ED 00 03  SUBSCRIPT 1 = 2
< > 02EF 00 00  ARRAY ELEMENTS ARE ALL 0

```

E.

```

<M>=OFF1 49 53  'IS'
< > OFF3 20 4E  ' N'
< > OFF5 4F 54  'OT'
< > OFF7 20 41  ' A'
< > OFF9 20 53  ' S'
< > OFFB 54 52  'TR'
< > OFFD 49 4E  'IN'
< > OFFF 47      'G'

```

6

RECREATION/APPLICATIONS

A Simple Securities Manager <i>Ronald A. Guest</i>	177
Solar System Simulation <i>Dave Partyka</i>	186
Othello <i>Charles F. Taylor, Jr.</i>	196
Musical Duets <i>Rick Brown</i>	201

Recreational/Applications

For your entertainment we've included "Othello" by Charles Taylor, Jr., and "Musical Duets" by Rick Brown. Othello is a fascinating board game for two players that is easy to learn and takes a lifetime to master. Musical Duets is a programmable music player that, with the help of a cassette recorder, even plays in stereo. A rendition of "Blue Bells of Scotland" is included.

For enlightenment, there is "Solar System Simulation" by David Partyka, which displays the motions of the first six planets against a star background. With this simulation you can see how the sky looked in the past or how it will look in the future. An advantage the program has over sky and telescope is that it can be used any time. So, if you ever get the urge to gaze at the stars and planets on a cloudy day or during lunch hour, get your Apple and gaze away!

When you're not keeping your eyes on shooting stars, maybe you should be watching the rise and fall of your stocks. "A Simple Securities Manager" by Ronald Guest can help you keep track of dividends paid, appreciation, and the current status of your portfolio.

A Simple Securities Manager

by Ronald A. Guest

Manage your stocks more carefully in these volatile times! Use this simple program to record security transactions, keep track of gains and losses, and evaluate your holdings at any time.

One of the many uses of a home computer is for record keeping. And one of the most profitable types of record to keep is security transactions. It has become increasingly more important to have accurate information readily at hand; a small computer can be a big help.

I have written a program to assist in making decisions about my holdings. This program runs on a 32K Apple with ROM Applesoft and a Disk II. The output of the program is heavily oriented toward the standard 24 × 40 Apple display, but as you will see, it produces adequate results when used with a hardcopy printer. Three types of reports may be generated, and four types of operations may be performed on the securities data.

The stock manager program is tailored to fit my own needs, and others may require different reports or formats. I will try to provide sufficient information in this article to allow the program to be modified easily.

Reports

Three types of reports which may be requested are: a listing of the data in the current portfolio, a listing of the appreciation in the portfolio, and a (very) rough estimate of the dividends paid by the portfolio. In all three of the reports, the user may select that all securities be listed, that all unsold securities be listed, or that all sold securities be listed.

The LIst report outputs all of the information stored in the disk file for the selected class of holdings. The information printed includes the first five characters of the name, the purchase and sale dates, the purchase and sale prices, the per share dividend, and the number of shares (figure 1). Up to five holdings may be printed per page, and the totals of the purchase prices and sale prices will

be printed on the final page. For an explanation of the meaning of the sale date and sale price for a security which has not yet been sold, see the paragraphs on adding an entry and on reading a data file.

The appreciation report lists the dollar and percent gains (losses) for each of the stocks listed. At the end of the report, the total dollar gain and the percent gain (loss) based on the purchase price are printed for the holdings selected (figure 2). If a security was sold 12 or more months after it was purchased, or if the security was purchased 12 or more months prior to the current date, then the name is displayed in inverse video indicating that the holding may be eligible for long-term gain.

A report of the dividends paid for the selected stocks provides an estimate of the dollar amount paid from the time the security was purchased to the time it was sold (or the current date if not yet sold). Only the selected securities with non-zero dividends are listed. The estimate is based on the number of months a security was held (figure 3). Since most securities pay dividends on specific dates, holdings which are quickly sold may show a dividend on the report, but have never been paid out. Since my investment goals are heavily oriented toward capital appreciation, the discrepancy does not bother me. People with different investment goals may wish to improve the estimates.

Operations on Data

The stock manager stores information in a sequential text file. A free format is used which allows each element to vary in length. The first element of the data file is a count of the number of entries in that file. The remainder of the file contains the entries. A security's entry, in the order of appearance, is: name, purchase date, sale date, purchase price, sale price, dividend, and number of shares.

When first run, the stock manager will have no entries, so the first command to execute is the **ADd** command. **ADd** requests the information which will be stored in the data file. All dates should be entered in the form **MMDDYY** with no slashes or other separators. The date must be six characters in length, so each field must be zero-filled. For instance, February 2, 1979 would be entered as **020279**. When adding an entry for an as yet unsold security, enter a single blank for the sale date.

After adding all of the entries desired, a **WRite** command should be performed. **WRite** will prompt for a file name, and then output the entries to disk. Before any reports are generated, a **REad** command should be executed. The **REad** will ask for the file name and then read the data file. After closing the data file, **REad** will prompt for the current price of all holdings which have not yet been sold. This price is then used in generating reports. Note that the price entered should be the total price, not the per share price.

If an error is made adding an entry, or if a holding is sold, the data may be updated with the **CHange** command. **CHange** searches for the given name and then requests the new information. If a holding is to be deleted, enter an ***** for the

Figure 1

```

ALL/NCTSOLD/SCLD ALL
PRESS 'RETURN' WHEN READY
NAME PDATF SDATE PPRICE SPRICE DIV
CETRI C21379 082779 1517.3 875.5 0
200
MEI 060179 2832.3 5124.3 3.5
100
PLUMM C31479 071579 5786.8 8514.1 0
200
TURKE C52278 827.3 1159.5 .8
400
4M 120579 879.3 945.8 1.3
150

TOTALS
PPRICES 11843
SPRICES 16619.1
PRESS 'RETURN' WHEN READY
    
```

Figure 2

```

CURRENT DATE (MMDDYY) 033180
ALL/NCTSCLF/SCLD ALL
PRESS 'RETURN' WHEN READY
NAME $GAIN %GAIN
CETRI -641.8 -42.3
MEI 2291.95 80.92
PLUMM 2727.3 47.13
TURKE 332.2 40.15
4M 66.45 7.56

TOTALS $GAIN 4776.1
%GAIN 40

PRESS 'RETURN' WHEN READY
    
```

Figure 3

```

CURRENT DATE (MMDDYY) 033180
ALL/NCTSOLD/SCLD ALL
PRESS 'RETURN' WHEN READY
NAME $GAIN %GAIN
MEI 262.5 9
TURKE 586.67 71
4M 48.75 6

TOTALS $GAIN 897.92
%GAIN 20

PRESS 'RETURN' WHEN READY
    
```

name. Be sure to do a WRite if the changes are to be permanent. If more than one entry in a portfolio has the same name (to the 25th character), the month purchased or some other difference should be introduced to allow a unique search. When the stock manager is EXited, it asks if the file should be updated. An answer of 'yes' will cause a WRite to be performed.

The stock manager was written to allow new commands or data fields to be added easily. To add a command, choose an unused entry in CMD\$ (denoted by 'XX') and substitute the first two characters of the new command (lines 130-133). Between lines 330-399, output the command name and description for the menu. On line 510, change the entry in the GOSUB list corresponding to the index into CMD\$ to the line number of the new command.

Adding a new data field is just as easy. Simply dimension the new field appropriately in lines 100-110. Then add a line in 36240-36280 to input the field, add a line in 38240-38255 to print the field, and add a line in 40110-40190 to enter the field into the data area. A list of the major variables and their usage is given in table 1 and a list of the subroutines is in table 2.

Users without a disk should change the REad routine to use BASIC READ and DATA statements. The WRite, CHange, and ADd routines can then be deleted since changes to the entries can be made by retyping the appropriate DATA statement. With these modifications, the program should easily run on a 16K cassette system (Applesoft in ROM).

See figure 4 for a sample of the displayed menu.

Figure 4

```

                                STOCK MANAGER 1.0
                                BY R.A. GUEST
                                MENU
ADD HOLDING
APPRECIATION
CHANGE HOLDING
DIVIDENDS
LIST HOLDINGS
READ DATA FILE
WRITE DATA FILE
EXIT
                                COMMAND: READ
FILE NAME TEMP
MBI
CURRENT PRICE 5124.25
TURKE
CURRENT PRICE 1159.50
4M
CURRENT PRICE 945.75
                                MENU
ADD HOLDING
APPRECIATION
CHANGE HOLDING
DIVIDENDS
LIST HOLDINGS
READ DATA FILE
WRITE DATA FILE
EXIT
                                COMMAND:

```

Table 1: List of Variables.

ANS	Indicates what class of stocks to list All(0) / Notsold(1) / Sold(2)
CC	Index of last entry in CMD\$
CD\$	Current date
CMD\$	Array of two character command names
COUNT	Number of holdings in current file
D\$	Control-D for DOS
DG	Dollar gain
DV	Array of per share dividends
F\$	File name containing stocks
INDEX	Index to stock holdings
LINE	Number of lines being displayed
MN	Number of months between sale (or current) date and purchase date
NM\$	Array of stock names
PD\$	Array of purchase dates
PP	Array of purchase prices
SD\$	Array of sale dates (1 blank if not sold)
SH	Array of number of shares
SP	Array of sale prices
TPP	Total purchase prices
TSP	Total sale prices
TV	Same as TPP
YR	Number of years between sale (or current) date and purchase date

Table 2: Routines and Their Uses

20000-21999	Appreciation Report
24000-25999	Change an Entry
28000-29999	Estimated Dividends Report
32000-33999	List Securities Entries
36000-37999	Read Securities from Disk
38000-39999	Write Securities to Disk
40000-41999	Add a New Entry
50000-50500	Print Header for List of Securities
51000-51500	Wait for Return to be Pressed
52000-52500	Print Header for Appreciation and dividend

```

10 REM *****
12 REM *
14 REM * STOCK HOLDINGS MGR *
16 REM * R. A. GUEST *
18 REM *
20 REM * COPYRIGHT (C) 1982 *
22 REM * MICRO INK, INC. *
24 REM * CHELMSFORD, MA 01824 *
26 REM * ALL RIGHTS RESERVED *
28 REM *
30 REM *****
40 REM
50 REM
100 DIM NM$(25),PD$(25),SD$(25),PP(25),SP(25),DV(25)
101 DIM CMD$(10),SH(25)
120 REM ** INIT COMMAND STRINGS **
130 CMD$(0) = "AP":CMD$(1) = "EX":CMD$(2) = "CH"
131 CMD$(3) = "XX":CMD$(4) = "DI":CMD$(5) = "XX"
132 CMD$(6) = "LI":CMD$(7) = "XX":CMD$(8) = "RE"
133 CMD$(9) = "WR":CMD$(10) = "AD"
135 COUNT = 0
140 CC = 10: REM LAST COMMAND
150 D$ = CHR$(4)
200 TEXT : HOME
210 VTAB 8: HTAB 12
220 PRINT "STOCK MANAGER 1.0"
230 VTAB 12: HTAB 13: INVERSE
240 PRINT "BY R.A. GUEST": NORMAL
250 FOR I = 1 TO 1000: NEXT I
300 REM DISPLAY MENU
310 HOME :T = FRE(0): REM CLEAN UP STRINGS
320 VTAB 2: HTAB 18
325 REM ** PRINT COMMANDS **
330 PRINT "MENU"
340 VTAB 4: INVERSE : PRINT "ADD";: NORMAL : PRINT " HOLDING"
350 INVERSE : PRINT "APPRECIATION"
360 PRINT "CHANGE";: NORMAL : PRINT " HOLDING"
370 INVERSE : PRINT "DIVIDENDS": NORMAL
380 INVERSE : PRINT "LIST";: NORMAL : PRINT " HOLDINGS"
390 INVERSE : PRINT "READ";: NORMAL : PRINT " DATA FILE"
395 INVERSE : PRINT "WRITE";: NORMAL : PRINT " DATA FILE"
399 INVERSE : PRINT "EXIT": NORMAL
400 VTAB 22: HTAB 10
410 INPUT "COMMAND: ";YN$
415 REM ** SEARCH FOR COMMAND **
420 FOR I = 0 TO CC: IF CMD$(I) = LEFT$(YN$,2) GOTO 500
430 NEXT
440 GOTO 400
500 I = I + 1
510 ON I GOSUB 20000,18000,24000,19000,28000,19000,32000,19000,36000,380
00,40000
600 GOTO 300
18000 REM ** EXIT **
18020 INPUT "DO YOU NEED TO UPDATE FILE ";YN$
18040 IF LEFT$(YN$,1) = "Y" THEN GOSUB 38000: REM CLEAR AND UPDATE
18060 END
19000 REM ** UNIMPLEMENTED **
19040 PRINT "NO SUCH COMMAND"
19060 RETURN
20000 REM CAPITAL GAINS(AP)
20010 REM HOLDINGS >1 YEAR
20020 REM INVERSED FOR LTG
20080 INPUT "CURRENT DATE (MMDDYY) ";CD$
20100 HOME : VTAB 10: HTAB 13
20120 INPUT "ALL/NOTSOLD/SOLD ";YN$
20140 ANS = 0: IF LEFT$(YN$,1) = "N" THEN ANS = 1
20160 IF LEFT$(YN$,1) = "S" THEN ANS = 2
20200 REM
20210 INDEX = 0: HOME :LINE = 30:DG = 0:TV = 0
20220 IF INDEX > = COUNT GOTO 20900: REM DONE
20230 IF ANS = 0 GOTO 20300
20240 IF (ANS = 1) AND (SD$(INDEX) < > " ") GOTO 20540
20250 IF (ANS = 2) AND (SD$(INDEX) = " ") GOTO 20540
20260 REM ** USE 'ADD' TO ENTER INFOR **
20300 REM OUTPUT HEADER

```

```

20320 IF LINE > 18 THEN GOSUB 52000
20330 F1 = 0: REM IF NOT SOLD, USE CURRENT DATA
20340 IF SD$(INDEX) = " " THEN F1 = 1:SD$(INDEX) = CD$
20349 REM ** CALCULATE YEAR DIFFERENCE **
20350 TP = VAL ( RIGHT$ (SD$(INDEX),2)) - VAL ( RIGHT$ (PD$(INDEX),2))
20351 TP = TP * 12: REM CONVERT TO MONTHS
20355 REM ** CALCULATE MONTH DIFFERENCE **
20360 TP = TP + VAL ( LEFT$ (SD$(INDEX),2)) - VAL ( LEFT$ (PD$(INDEX),2))
20362 REM ** DELETE ENTRY **
20365 IF TP < 12 GOTO 20395
20370 INVERSE : REM LONG TERM GAIN
20395 IF F1 THEN SD$(INDEX) = " "
20400 PRINT LEFT$ (NM$(INDEX),10);: NORMAL : HTAB 12
20410 REM ** CALCULATE DOLLAR GAIN **
20420 TP$ = STR$ ( INT ((SP(INDEX) - PP(INDEX)) * 100 + .5) / 100)
20430 IF LEN (TP$) < 8 THEN TP$ = " " + TP$: GOTO 20430
20440 PRINT TP$;: HTAB 20
20450 DG = DG + VAL (TP$): REM TOTAL DOLLAR VALUE
20460 TV = PP(INDEX) + TV: REM TOTAL VALUE
20465 REM ** CALCULATE % GAIN **
20470 TT = ( VAL (TP$) / PP(INDEX)) * 100
20480 TT$ = STR$ ( INT (TT * 100 + .5) / 100): REM PERCENT GAIN
20490 IF LEN (TT$) < 7 THEN TT$ = " " + TT$: GOTO 20490
20500 PRINT TT$
20520 LINE = LINE + 1
20540 INDEX = INDEX + 1
20560 GOTO 20220: REM DO NEXT ONE
20890 REM ** PRINT TOTALS **
20900 PRINT : PRINT "TOTALS";: HTAB 10: PRINT "$GAIN ";DG
20910 IF TV = 0 GOTO 20940
20920 HTAB 10: PRINT "%GAIN ";( INT ((DG / TV) * 100 + .5))
20940 PRINT
20960 GOSUB 51000: REM WAIT FOR KEY PRESS
20970 RETURN
24000 REM ** CHANGE/DELETE HOLDING **
24020 REM ** INPUT '*' FOR NAME TO DELETE **
24040 REM ** INPUT A BLANK FOR SALE DATE IF NOT YET SOLD **
24200 INPUT "SEARCH STRING ";TS$
24220 FOR K = 0 TO (COUNT - 1)
24222 IF TS$ = LEFT$(NM$(K), LEN (TS$)) GOTO 24300
24225 NEXT K
24240 PRINT "NOT FOUND": FOR KK = 1 TO 300: NEXT : RETURN
24300 TP = COUNT:COUNT = K
24302 PRINT NM$(K): PRINT PD$(K): PRINT SD$(K): PRINT PP(K): PRINT SP(K)
: PRINT DV(K): PRINT SH(K)
24320 PRINT "ENTER '*' FOR NAME TO DELETE."
24330 FOR KK = 1 TO 400: NEXT
24340 GOSUB 40100: REM GET FIELDS
24360 IF NM$(K) < > "" THEN COUNT = TP: RETURN
24365 COUNT = COUNT - 1
24367 REM ** MOVE REST DOWN IN LIST **
24370 FOR K = COUNT TO TP - 2
24380 K1 = K + 1
24390 NM$(K) = NM$(K1):PD$(K) = PD$(K1):SD$(K) = SD$(K1)
24400 PP(K) = PP(K1):SP(K) = PP(K1):DV(K) = DV(K1):SH(K) = SH(K1)
24420 NEXT
24440 COUNT = TP - 1
24460 RETURN
26000 REM ** CLEAR SALE PRICE OF UNSOLDS **
26100 FOR I = 0 TO COUNT - 1
26120 IF SD$(I) = " " THEN SP(I) = 0
26140 NEXT
26200 RETURN
28000 REM ** ESTIMATE DIVIDEND GAIN **
28020 INPUT "CURRENT DATE (MMDDYY) ";CD$
28040 HOME : VTAB 10: HTAB 13
28060 INPUT "ALL/NOTSOLD/SOLD ";YN$
28080 ANS = 0: IF LEFT$(YN$,1) = "N" THEN ANS = 1
28100 IF LEFT$(YN$,1) = "S" THEN ANS = 2
28120 INDEX = 0: HOME :LINE = 30:DG = 0:TV = 0
28180 REM ** TEST IF DONE **
28200 IF INDEX > = COUNT THEN 28900
28220 IF ANS = 0 GOTO 28280
28240 IF (ANS = 1) AND (SD$(INDEX) < > " ") GOTO 28620
28260 IF (ANS = 2) AND (SD$(INDEX) = " ") GOTO 28620

```

```

36000 REM ** READ STOCK LISTING FILE **
36100 INPUT "FILE NAME ";F$
36120 PRINT D$;"OPEN ";F$
36140 PRINT D$;"READ ";F$
36200 INPUT COUNT
36220 FOR I = 0 TO (COUNT - 1)
36240 INPUT NM$(I): INPUT PD$(I): INPUT SD$(I)
36260 INPUT PP(I): INPUT SP(I)
36280 INPUT DV(I): INPUT SH(I)
36285 REM ** CHECK FOR NOT SOLD **
36290 IF LEN (SD$(I)) < 6 THEN SD$(I) = " "
36300 NEXT
36320 PRINT D$;"CLOSE ";F$
36325 REM ** GET PRICES FOR STOCKS NOT SOLD **
36330 FOR I = 0 TO (COUNT - 1)
36340 IF SD$(I) < > " " GOTO 36370
36350 PRINT NM$(I)
36360 INPUT "CURRENT PRICE ";SP(I)
36370 NEXT
36400 RETURN
38000 REM ** UPDATE STOCK LISTING FILE **
38050 GOSUB 26000: REM CLEAR NOT SOLD PRICES
38100 INPUT "FILE NAME ";F$
38120 PRINT D$;"OPEN ";F$
38140 PRINT D$;"WRITE ";F$
38200 PRINT COUNT
38220 FOR I = 0 TO (COUNT - 1)
38240 PRINT NM$(I): PRINT PD$(I): PRINT SD$(I)
38242 PRINT PP(I): PRINT SP(I): PRINT DV(I): PRINT SH(I)
38260 NEXT
38300 PRINT D$;"CLOSE ";F$
38320 RETURN
40000 REM ** ADD A HOLDING **
40080 HOME : VTAB 4
40100 INPUT "NAME ";NM$(COUNT)
40110 PRINT "INPUT DATES IN THE FORM (MMDDYY)"
40120 NM$(COUNT) = LEFT$(NM$(COUNT),25)
40140 INPUT "PURCH DATE ";PD$(COUNT):PD$(COUNT) = LEFT$(PD$(COUNT),6)
40145 PRINT "ENTER A SINGLE BLANK IF NOT SOLD"
40150 INPUT "SALE DATE ";SD$(COUNT):SD$(COUNT) = LEFT$(SD$(COUNT),6)
40155 IF SD$(COUNT) = "" THEN SD$(COUNT) = " "
40160 INPUT "PURCH PRICE ";PP(COUNT)
40170 INPUT "SALE PRICE ";SP(COUNT)
40180 INPUT "DIVIDEND/SHARE ";DV(COUNT)
40190 INPUT "SHARES ";SH(COUNT)
40300 COUNT = COUNT + 1
40400 RETURN
50000 REM ** WAIT FOR (CR) THEN **
50010 REM ** OUTPUT HEADING FOR 'LIST' **
50020 REM
50100 GOSUB 51000: HOME
50110 PRINT "NAME ";
50120 PRINT "PDATE ";
50130 PRINT "SDATE ";
50140 PRINT "PPRICE ";
50150 PRINT "SPRICE ";
50160 PRINT "DIV "
50170 PRINT
50200 LINE = 2
50300 RETURN
51000 REM ** WAIT FOR (CR) TO BE PRESSED **
51010 VTAB 23: HTAB 5
51020 PRINT "PRESS 'RETURN' WHEN READY "
51050 POKE - 16368,0
51100 IF PEEK ( - 16384) = 141 THEN RETURN
51200 GOTO 51100
52000 REM ** WAIT FOR (CR) AND **
52020 REM ** PRINT HEADER **
52040 REM ** FOR APPRECIATION AND DIVIDEND **
52060 GOSUB 51000: HOME : HTAB 4
52080 PRINT "NAME";: HTAB 14
52100 PRINT "$GAIN";: HTAB 21
52120 PRINT "%GAIN"
52140 PRINT
52160 LINE = 2
52180 RETURN

```

```

28270 REM ** PRINT HEADER **
28280 IF LINE > 18 THEN GOSUB 52000
28290 REM ** USE CURRENT DATE OR UNSOLDS **
28300 IF DV(INDEX) = 0 GOTO 28620: REM DON'T USE
28305 F1 = 0
28310 IF SD$(INDEX) = " " THEN F1 = 1:SD$(INDEX) = CD$
28315 REM ** CALCULATE MONTHS **
28320 MN = VAL ( LEFT$( SD$(INDEX),2) ) - VAL ( LEFT$( PD$(INDEX),2) )
28323 REM ** CALCULATE YEARS **
28325 YR = VAL ( RIGHT$( SD$(INDEX),2) ) - VAL ( RIGHT$( PD$(INDEX),2) )
28327 REM ** CONVERT TO MONTHS **
28330 MN = MN + YR * 12
28340 IF F1 THEN SD$(INDEX) = " "
28400 PRINT LEFT$( NM$(INDEX),10);: HTAB 12
28410 REM ** ESTIMATE DIVIDENDS PAID **
28420 TP = INT ( (DV(INDEX) * SH(INDEX) * (MN / 12)) * 100 + .5) / 100
28440 TP$ = STR$( TP )
28460 IF LEN ( TP$ ) < 8 THEN TP$ = " " + TP$: GOTO 28460
28480 PRINT TP$;: HTAB 20
28490 REM ** CALCULATE DOLLAR GAIN AND **
28495 REM ** TOTAL VALUE **
28500 DG = DG + VAL ( TP$ ):TV = TV + PP(INDEX)
28510 REM ** CALCULATE % GAIN **
28520 TT = INT ( ( VAL ( TP$ ) / PP(INDEX) ) * 100 + .5 )
28540 TT$ = STR$( TT )
28560 IF LEN ( TT$ ) < 7 THEN TT$ = " " + TT$: GOTO 28560
28580 PRINT TT$
28600 LINE = LINE + 1
28620 INDEX = INDEX + 1
28640 GOTO 28200
28900 GOSUB 20900: REM OUTPUT TOTALS
28920 RETURN
32000 REM ** LIST CURRENT HOLDINGS **
32100 HOME : VTAB 10: HTAB 10
32110 INPUT "ALL/NOTSOLD/SOLD ";YNS$
32120 ANS = 0: REM ALL
32130 IF LEFT$( YNS$,1) = "N" THEN ANS = 1: REM NOTSOLD
32140 IF LEFT$( YNS$,1) = "S" THEN ANS = 2: REM SOLD
32210 INDEX = 0: HOME :LINE = 30:TPP = 0:TSP = 0
32300 IF INDEX > = COUNT GOTO 32900
32302 IF ANS = 0 GOTO 32310
32304 IF (ANS = 1) AND (SD$(INDEX) = " ") GOTO 32310
32306 IF (ANS = 2) AND (SD$(INDEX) < > " ") GOTO 32310
32308 INDEX = INDEX + 1: GOTO 32300
32310 IF LINE > 18 THEN GOSUB 50000: REM WAIT AND PRINT HEADER
32320 PRINT LEFT$( NM$(INDEX),5);: HTAB 7
32330 PRINT LEFT$( PD$(INDEX),6);: HTAB 14
32340 PRINT LEFT$( SD$(INDEX),6);: HTAB 21
32350 REM ** PURCHASE PRICE **
32360 TP$ = STR$( INT ( PP(INDEX) * 10.0 + 0.5) / 10.0 )
32380 IF LEN ( TP$ ) < 7 THEN TP$ = " " + TP$: GOTO 32380
32390 PRINT TP$;: HTAB 29
32395 REM ** SALE PRICE **
32400 TP$ = STR$( INT ( SP(INDEX) * 10.0 + 0.5) / 10.0 )
32410 IF LEN ( TP$ ) < 7 THEN TP$ = " " + TP$: GOTO 32410
32420 PRINT TP$;: HTAB 37
32425 REM ** DIVIDEND **
32430 TP$ = STR$( INT ( DV(INDEX) * 10.0 + 0.5) / 10.0 )
32440 IF LEN ( TP$ ) < 3 THEN TP$ = " " + TP$: GOTO 32440
32450 PRINT TP$
32455 REM ** NUMBER OF SHARES **
32460 PRINT " ";SH(INDEX)
32465 REM ** COMPUTE TOTAL SALES AND **
32466 REM ** TOTAL PURCHASE PRICES **
32470 TSP = TSP + SP(INDEX):TPP = TPP + PP(INDEX)
32480 PRINT
32800 LINE = LINE + 3
32810 INDEX = INDEX + 1
32820 GOTO 32300
32880 REM ** PRINT TOTALS **
32900 PRINT : PRINT "TOTALS"
32910 HTAB 10: PRINT "PPRICES ";TPP
32920 HTAB 10: PRINT "SPRICES ";TSP
32960 GOSUB 51000: REM WAIT FOR KEY PRESS
32970 RETURN

```

Solar System Simulation

by Dave Partyka

This program will print information about the first six planets of the Solar System, and plot their positions. In the printing mode, information such as distance from the earth and sun, and other data about the earth and planet relation is printed. In the plot mode, the planets' positions against the zodiac, as seen from the earth, are plotted, using hi-res graphics and scaling factors.

This program deals with the first six planets, but instead of being heliocentric (sun centered) it's geocentric (earth centered). It gives a display of the planets as seen from the earth. The planets are displayed against a star background and their motions through the zodiac are very good representations of the actual positions of the planets. Using this program, you can watch as a planet makes its retrograde loop through a constellation, see how close two or more planets come to each other, or watch how close a planet comes to a bright star.

The program is set up in two parts. One part prints values on the screen for each planet and the sun, and the other plots the positions of the planets against a star background. If you choose to print, at the top of the screen is the starting date and the number of days that the display is for. The program then prints the following data for each planet:

D-S; the distance in million miles that the planet is from the sun.

A-S; the angle in degrees that the planet is located around the sun.

D-E; the distance in million miles that the planet is from the earth.

R.A.; the right ascension in hours and minutes that the planet appears from the earth.

DEC.; the declination in degrees and minutes that the planet appears from the earth.

You can display the values for all the planets, or for specific ones. You can display a single day, or a range of days with any number of days between the displays. The program will pause after each display, and then wait for you to press RETURN to continue with the display, or with a set of questions for a new display.

If you choose to plot, another set of questions will be asked. These are needed to set the limits for the star display and to determine if you want point or continuous plots. Just like printing, you can plot for single or multiple days, with any number of days between plots. You can plot single points (with the previous plot erased before the current one is plotted), or continuous plots (where the points aren't erased but remain on the screen). After that you'll be asked for a scaling factor: 0 or 1-20. A scaling factor of zero will display the full star field, right ascension 0 to 24 hours, and declination 90 to -90 degrees.

A scaling factor equal to or greater than 1 (a factor between zero and one is not allowed) displays another question, "Enter center coordinates for R.A. and DEC." This will determine the center coordinates of the display, and is in hours and decimal hours, degrees and decimal degrees. The scaling factor you entered, along with the center coordinates, will determine the right and left, top and bottom limits of the display.

The higher the scaling factor, the less of a constellation you'll see, but the greater the movement of the planet per plot. A scaling factor of 1 displays approximately 18 hours in right ascension and 180 degrees in declination, and a factor of 10 displays, approximately 2 hours in right ascension and 19 degrees in declination.

The only constellations in the star table are for the zodiac. If you want to increase the number of stars within the zodiac, or if you want to add more constellations, it's an easy process. The table is set up with four values per star. The first two are for right ascension in hours, minutes; the next two are for declination in degrees, minutes. The stars in the table don't have to be in any particular order. The whole table is read when the plot portion of the program is used. The only table requirements are the two values for right ascension and two values for declination. If the declination is negative, then both values for declination have to be negative. To end the table, four zeros are necessary — 0,0,0,0.

You may want to split this program to make one that just displays the stars on the screen. Just begin where the question for a scaling factor is asked, and delete everything else that isn't used. You can add more tables to the new program: one for galaxies, another for star clusters, another for nebulae, or even one for the Messier objects. The tables you add will be whatever you need, and by adding more questions, you can display the different tables, either alone or combined.

Let's go through two examples of the program, first for figure 1, and second for figure 2. The first question that will be asked is if you want to display the same planets as your last run. Since this is the first run, enter N. Then it will ask "What planets do you want to display?" Enter a 1 for each planet. Then a starting date is asked. Use 11,1,1979. After that, it says "Enter the number of days to plot." Enter 150. Then it asks to print or plot. Enter a 1 to print. The screen will then clear,

print the starting date and the plot day's value at the top of the screen, and then continue to print for the planets and the sun.

After finishing the page, it will pause and display "Press return for next display." After you press return it will start printing again, changing the plot day's value at the top of the page and the values for the planets and the sun. It will continue to do this until the plot day's value is equal to or greater than the day's that you wanted to print for. After that, it will ask you to press return to start again. When you press return, it will ask if you want to display the same planets as your last run.

Figure 1: Example of the print routine for all planets, starting date 11/1/1979 for 240 days at 50-day intervals at the 150th day.

	Starting Date 11/1/1979		Plot Days 150		
Earth	D-S.	92.8887	Sun	D-E.	92.8887
	A-S.	189.4489		R.A.	0 34.7
Mercury	D-S.	43.1581	Venus	DEC.	3 44.6
	A-S.	245.1156		D-S.	66.8181
	D-E.	77.2616		A-S.	140.7176
	R.A.	22 55.3		D-E.	70.0302
Mars	DEC.	-8 7.1	R.A.	3 28.3	
	D-S.	154.4251	DEC.	21 55	
	A-S.	170.2956	Jupiter	D-S.	502.2398
	D-E.	73.2592		A-S.	158.0192
R.A.	9 56.5	D-E.		425.652	
DEC.	16 7	R.A.		10 15.9	
Saturn	D-S.	875.6875	DEC.	12 9.5	
	A-S.	174.1555			
	D-E.	785.842			
	R.A.	11 35.7			
	DEC.	5 15			

Press return for next display.

For example 2, enter an N to the last question so that it will ask you which planets you want to display. Enter a 0 (zero) for all the planets except Mars. Enter 11,1,1979 for the starting date, 240 for the number of days to plot, and 10 for the number of days between plots. When it asks to print or plot, enter a 0 (zero) to plot. Three requests will then be made: the first, "enter 0 for point, or 1 for continuous plots." Since we want all the points to remain on the screen, enter 1 for continuous plots. The next question is the scaling factor. Enter a 5. After that will be the center coordinates. Since I already know that the planet Mars will be in the constellation Leo, enter 10.5 for right ascension, and 18 for declination.

When you do plots for other planets and you don't know where they will be, run the print program first and get the right ascension and declination. After entering the center coordinates, the screen will clear and a window will appear on the screen. After a few seconds the constellation Leo will appear as the star table is read, and any stars within the display limits will be plotted. A few more seconds will pass as the rest of the table is read. Once the end of the table is found, the program will beep to signal the start of the calculations.

Since the planet Mars was the only planet picked, the program will calculate the positions of the earth and Mars. The position of the earth is always calculated, but only printed during the print option, (if you choose to print it). The program will continue to plot the position of Mars, beeping each time it starts a new sequence of calculations. It will plot 25 times — one for the starting date and 24 for 240 days, at 10-day intervals.

The program will then do a double beep to signal the end of the simulation and wait until you press return before starting a new sequence of questions. The purpose of the single beep at the beginning of the calculations is to identify what planet is being plotted. The planets are plotted in their order from the sun. If you plot more than one planet in the same display, you can figure out which is which by the plotting order.

Figure 2: Example of the plot routine for Mars, starting date 11/1/1979 for 240 days at 10-day intervals, continuous plots.

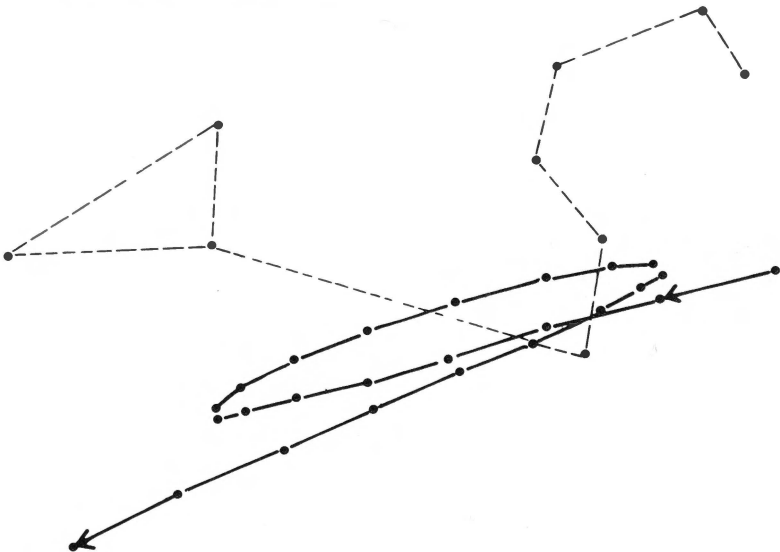

Since the date doesn't appear anywhere on the display for plotting, you can do a CNTL-C to stop the program, type "TEXT", and then return to see the starting date and the plot day's value. To continue, do POKEs to set graphics mode (-16304) and display the secondary page (-16299), type "CONT" and return. The program will pick up where you left off. If you follow these examples, the results you get should match figure 1 at day 150 for printing, and figure 2 at the end of the plotting sequence. The solid and dotted lines in figure 2 were used to show the motion of Mars and the stars of the constellation Leo, and will not be in the actual display. Once you run the two examples to become familiar with the program, then you can enter any values for the questions to display whatever for whenever you want.

```

10 REM *****
15 REM *
20 REM * SOLAR SYSTEM *
25 REM * SIMULATION *
27 REM * DAVE PARTYKA *
30 REM *
35 REM * COPYRIGHT (C) 1982 *
40 REM * MICRO INK, INC. *
44 REM * CHELMSFORD, MA 01824 *
45 REM * ALL RIGHTS RESERVED *
50 REM *
55 REM *
60 REM *****
65 REM
70 REM
75 REM
100 GOTO 650
110 IF TY = 1 THEN 210
120 IF H > TP OR H < BT THEN 210
130 HCOLOR= 0
140 IF RG > LF THEN 180
150 IF F < RG OR F > LF THEN 210
160 HPLOT 279 - (F - RG) * SC, (TP - H) * SC
170 GOTO 210
180 IF F > LF AND F < RG THEN 210
190 IF F = < LF THEN F = F + 360
200 HPLOT 279 - (F - RG) * SC, (TP - H) * SC
210 IF G > TP OR G < BT THEN RETURN
220 HCOLOR= 3
230 IF RG > LF THEN 270
240 IF B < RG OR B > LF THEN RETURN
250 HPLOT 279 - (B - RG) * SC, (TP - G) * SC
260 RETURN
270 IF B > LF AND B < RG THEN RETURN
280 IF B = < LF THEN B = B + 360
290 HPLOT 279 - (B - RG) * SC, (TP - G) * SC
300 RETURN
310 D = ZZ - INT (ZZ / SRD) * SRD
320 B = Q - (D / SRD * Q2)
330 IF Y > 0 THEN RA = 270
340 RV = A - (P / (1 + E * COS (B)))
350 V = PE / RV - EZ
360 IF V = > 1 THEN V = VL
370 IF V = < - 1 THEN V = - VL
380 VA = - ATN (V / SQRT (- V * V + 1)) + T
390 IF D > SRD / 2 THEN VA = Q2 - VA
400 VA = VA + J
410 ZX = VA * T1 - C
420 IF ZX > 360 THEN ZX = ZX - 360
430 IF ZX < 0 THEN ZX = 360 + ZX
440 ZX = ZX / T1
450 LA = SIN (ZX) * I
460 XA = RV * COS (LA) * COS (VA)
470 YA = RV * COS (LA) * SIN (VA)
480 ZA = RV * SIN (LA)

```

```

490 XB = XA - X3:YB = YA - Y3:ZB = ZA - Z3
500 VA = VA * T1
510 IF VA > 360 THEN VA = VA - 360
520 IF EE = 0 THEN RETURN
530 ED = SQR (XB * XB + YB * YB)
540 X = XB
550 Y = YB * COS (IN) - ZB * SIN (IN)
560 Z = YB * SIN (IN) + ZB * COS (IN)
570 RA = 90
580 IF Y < 0 THEN RA = 270
590 IF X < > 0 THEN RA = ATN (Y / X) * T1
600 IF X < 0 THEN RA = RA + 180
610 IF X > 0 AND Y < 0 THEN RA = RA + 360
620 DZ = Z / ED
630 DC = ATN (DZ / SQR (1 - DZ * DZ)) * T1
640 RETURN
650 T = 1.5708:T1 = 57.2957795
660 IN = 23.434 / T1
670 Q = 3.14159265
680 Q2 = 6.2831853
690 VL = .999999999
700 HOME
710 PRINT "DO YOU WANT TO DISPLAY "
720 PRINT : PRINT "THE SAME PLANETS AS YOUR LAST RUN"
730 PRINT : INPUT "Y OR N ";A$
740 IF A$ = "N" THEN 790
750 IF A$ < > "Y" THEN 710
760 IF S1 < > 0 THEN 1590
770 IF SC < > 0 THEN 2785
780 PRINT : PRINT "YOU HAV'NT PICKED THE PLANETS YET": PRINT : PRINT : GOTO
800
790 HOME
800 PRINT "CHOOSE THE PLANETS YOU WANT TO DISPLAY"
810 PRINT
820 PRINT "ENTER A 1 FOR YES, 0 FOR NO"
830 PRINT
840 REM SPACIFIC VALUES FOR EACH PLANET
850 REM S1=ORBITAL PERIOD: P1=A1*(1-E1*E1)/2
860 REM E1=ECCENTRICITY: U1=P1/E1: K1=1/E1
870 REM A1=MINIMUM + MAXIMUM DISTANCE FROM SUN
880 REM J1=LONGITUDE OF PERIHELION IN RADIANIS
890 REM W1=DAYS FROM 0 DEGREES TO PERIHELION FOR 1980
892 REM C1=ASCENDING NODE IN DEGREES
894 REM I1=INCLINATION IN DEGREES / T1 TO CONVERT TO RADIANIS
900 INPUT "DISPLAY MERCURY ";ME
910 S1 = 87.969
920 E1 = .2056
930 A1 = 43.403 + 28.597
940 P1 = A1 * (1 - E1 * E1) / 2
950 K1 = 1 / E1
960 U1 = P1 / E1
970 J1 = 77.1 * Q / 180
980 W1 = 37.53
990 C1 = 48.1
1000 I1 = 7 / T1
1010 INPUT "DISPLAY VENUS ";VE
1020 S2 = 224.701
1030 E2 = .0068
1040 A2 = 67.726 + 66.813
1050 P2 = A2 * (1 - E2 * E2) / 2
1060 K2 = 1 / E2
1070 U2 = P2 / E2
1080 J2 = 131.3 * Q / 180
1090 W2 = 140.5
1100 C2 = 76.5
1110 I2 = 3.4 / T1
1120 INPUT "DISPLAY EARTH ";EA
1130 S3 = 365.256
1140 E3 = .0167
1150 A3 = 94.555 + 91.445
1160 P3 = A3 * (1 - E3 * E3) / 2
1170 K3 = 1 / E3
1180 U3 = P3 / E3
1190 J3 = 102.6 * Q / 180
1200 W3 = - 3.82

```

```

1210 C3 = 0
1220 I3 = 0
1230 INPUT "DISPLAY MARS          ";MA
1240 S4 = 686.980
1250 E4 = .0934
1260 A4 = 154.936 + 128.471
1270 P4 = A4 * (1 - E4 * E4) / 2
1280 K4 = 1 / E4
1290 U4 = P4 / E4
1300 J4 = 335.7 * Q / 180
1310 W4 = 287
1320 C4 = 49.4
1330 I4 = 1.85 / T1
1340 INPUT "DISPLAY JUPITER      ";JU
1350 S5 = 4332.125
1360 E5 = .0478
1370 A5 = 507.046 + 460.595
1380 P5 = A5 * (1 - E5 * E5) / 2
1390 K5 = 1 / E5
1400 U5 = P5 / E5
1410 J5 = 13.6 * Q / 180
1420 W5 = 1608
1430 C5 = 100.24
1440 I5 = 1.3 / T1
1450 INPUT "DISPLAY SATURN       ";SA
1460 S6 = 10825.863
1470 E6 = .0555
1480 A6 = 937.541 + 838.425
1490 P6 = A6 * (1 - E6 * E6) / 2
1500 K6 = 1 / E6
1510 U6 = P6 / E6
1520 J6 = 95.5 * Q / 180
1530 W6 = 2090
1540 C6 = 113.51
1550 I6 = 2.49 / T1
1590 HOME
1600 PRINT "ENTER BEGINNING DATE? MM,DD,YYYY": INPUT "
      ";MM,DD,YY
1610 DF = (MM = 2) * 31 + (MM = 3) * 59 + (MM = 4) * 90 + (MM = 5) * 120 +
      (MM = 6) * 151 + (MM = 7) * 181 + (MM = 8) * 212 + (MM = 9) * 243 +
      (MM = 10) * 273 + (MM = 11) * 304 + (MM = 12) * 334
1620 ZY = INT (YY * 365 + INT (YY / 4) + DD + DF + 1 - INT (YY / 100) +
      INT (YY / 400) / 1)
1630 IF INT (YY / 4) < > YY / 4 THEN 1680
1640 IF INT (YY / 400) = YY / 400 THEN 1660
1650 IF INT (YY / 100) = YY / 100 THEN 1670
1660 IF MM > 2 THEN 1680
1670 ZY = ZY - 1
1680 ZY = ZY - 723180
1690 ZT = - ZY
1700 PRINT : PRINT : INPUT "ENTER # OF DAYS TO PRINT/PLOT ";DN
1710 PRINT : PRINT : PRINT
1720 INPUT "ENTER # OF DAYS BETWEEN PRINT/PLOTS ";DA
1730 IF DA < > 0 THEN 1760
1740 PRINT : PRINT
1750 PRINT "0 NOT ALLOWED": GOTO 1710
1760 HOME
1770 INPUT "ENTER 1 TO PRINT, 0 TO PLOT ";PL
1780 IF PL < > 0 AND PL < > 1 THEN 1760
1785 IF PL = 0 THEN PRINT : PRINT "DO YOU WANT": PRINT : INPUT "POINT (
      0) OR CONTINUOUS (1) PLOTS ";TY
1786 IF TY < > 0 AND TY < > 1 THEN 1785
1790 IF PL = 0 THEN GOSUB 2750
1800 REM EARTH
1810 HOME :EE = 0
1830 A = A3:P = P3:E = E3:PE = U3:EZ = K3:SRD = S3:J = J3:W = W3:ZZ = ZY +
      W:C = C3:I = I3
1840 GOSUB 310:EE = 1
1845 X3 = XA:Y3 = YA:Z3 = ZA:R3 = RV:V3 = VA
1848 HOME
1850 VTAB 1: HTAB 1: PRINT "STARTING DATE ";MM;"/";DD;"/";YY;" PLOT DA
      YS ";ZT + ZY
1855 IF PL = 0 THEN VTAB 23: PRINT "STARTING DATE ";MM;"/";DD;"/";YY;"
      PLOT DAYS ";ZT + ZY: PRINT "": GOTO 1980: REM EMPTY PRINT IS A CN
      TL-G (BELL)

```

```

1870 IF EA = 0 THEN 1980
1880 VTAB 2: HTAB 1: PRINT "EARTH D-S. "; INT (RV * 10000) / 10000
1890 VTAB 3: HTAB 7: PRINT "A-S. "; INT (V3 * 10000) / 10000
1900 REM SUN
1910 XB = - X3:YB = - Y3:ZB = - Z3:ED = R3
1920 GOSUB 540
1930 VTAB 2: HTAB 21: PRINT "SUN D-E. "; INT (ED * 10000) / 10000
1940 VTAB 3: HTAB 28: PRINT "R.A. "; INT (RA / 15);" "; INT ((RA - INT
(RA / 15) * 15) * 40) / 10
1950 IF DC < 0 THEN DC = - DC:DB = 1
1960 VTAB 4: HTAB 28: PRINT "DEC. "; INT (DC);" "; INT ((DC - INT (DC)
) * 600) / 10
1970 IF DB = 1 THEN VTAB 4: HTAB 32: PRINT "-":DB = 0
1980 REM MERCURY
1990 IF ME = 0 THEN 2130
2000 A = A1:P = P1:E = E1:PE = U1:EZ = K1:SRD = S1:J = J1:W = W1:ZZ = ZY +
W:C = C1:I = I1
2010 GOSUB 310: IF PL = 1 THEN 2050
2020 F = F1:H = H1:B = RA:G = DC: GOSUB 110
2030 F1 = RA:H1 = DC: GOTO 2130
2040 IF PL = 0 THEN GOSUB 110
2050 VTAB 6: HTAB 1: PRINT "MERC D-S. "; INT (RV * 10000) / 10000
2060 VTAB 7: HTAB 7: PRINT "A-S. "; INT (VA * 10000) / 10000
2070 VTAB 8: HTAB 7: PRINT "D-E. "; INT (ED * 10000) / 10000
2080 VTAB 9: HTAB 7: PRINT "R.A. "; INT (RA / 15);" "; INT ((RA - INT
(RA / 15) * 15) * 40) / 10
2090 IF DC < 0 THEN DC = - DC:DB = 1
2100 VTAB 10: HTAB 7: PRINT "DEC. "; INT (DC);" "; INT ((DC - INT (DC)
) * 600) / 10
2110 IF DB = 1 THEN VTAB 10: HTAB 11: PRINT "-":DB = 0
2120 REM VENUS
2130 IF VE = 0 THEN 2260
2140 A = A2:P = P2:E = E2:PE = U2:EZ = K2:SRD = S2:J = J2:W = W2:ZZ = ZY +
W:C = C2:I = I2
2150 GOSUB 310: IF PL = 1 THEN 2180
2160 F = F2:H = H2:B = RA:G = DC: GOSUB 110
2170 F2 = RA:H2 = DC: GOTO 2260
2180 VTAB 6: HTAB 21: PRINT "VENUS D-S. "; INT (RV * 10000) / 10000
2190 VTAB 7: HTAB 28: PRINT "A-S. "; INT (VA * 10000) / 10000
2200 VTAB 8: HTAB 28: PRINT "D-E. "; INT (ED * 10000) / 10000
2210 VTAB 9: HTAB 28: PRINT "R.A. "; INT (RA / 15);" "; INT ((RA - INT
(RA / 15) * 15) * 40) / 10
2220 IF DC < 0 THEN DC = - DC:DB = 1
2230 VTAB 10: HTAB 28: PRINT "DEC. "; INT (DC);" "; INT ((DC - INT (DC)
) * 600) / 10
2240 IF DB = 1 THEN VTAB 10: HTAB 32: PRINT "-":DB = 0
2250 REM MARS
2260 IF MA = 0 THEN 2390
2270 A = A4:P = P4:E = E4:PE = U4:EZ = K4:SRD = S4:J = J4:W = W4:ZZ = ZY +
W:C = C4:I = I4
2280 GOSUB 310: IF PL = 1 THEN 2310
2290 F = F4:H = H4:B = RA:G = DC: GOSUB 110
2300 F4 = RA:H4 = DC: GOTO 2390
2310 VTAB 12: HTAB 1: PRINT "MARS D-S. "; INT (RV * 10000) / 10000
2320 VTAB 13: HTAB 7: PRINT "A-S. "; INT (VA * 10000) / 10000
2330 VTAB 14: HTAB 7: PRINT "D-E. "; INT (ED * 10000) / 10000
2340 VTAB 15: HTAB 7: PRINT "R.A. "; INT (RA / 15);" "; INT ((RA - INT
(RA / 15) * 15) * 40) / 10
2350 IF DC < 0 THEN DC = - DC:DB = 1
2360 VTAB 16: HTAB 7: PRINT "DEC. "; INT (DC);" "; INT ((DC - INT (DC)
) * 600) / 10
2370 IF DB = 1 THEN VTAB 16: HTAB 11: PRINT "-":DB = 0
2380 REM JUPITER
2390 IF JU = 0 THEN 2520
2400 A = A5:P = P5:E = E5:PE = U5:EZ = K5:SRD = S5:J = J5:W = W5:ZZ = ZY +
W:C = C5:I = I5
2410 GOSUB 310: IF PL = 1 THEN 2440
2420 F = F5:H = H5:B = RA:G = DC: GOSUB 110
2430 F5 = RA:H5 = DC: GOTO 2520
2440 VTAB 12: HTAB 21: PRINT "JUPTR D-S. "; INT (RV * 10000) / 10000
2450 VTAB 13: HTAB 28: PRINT "A-S. "; INT (VA * 10000) / 10000
2460 VTAB 14: HTAB 28: PRINT "D-E. "; INT (ED * 10000) / 10000
2470 VTAB 15: HTAB 28: PRINT "R.A. "; INT (RA / 15);" "; INT ((RA - INT
(RA / 15) * 15) * 40) / 10
2480 IF DC < 0 THEN DC = - DC:DB = 1
    
```

194 Recreation/Applications

```

2490 VTAB 16: HTAB 28: PRINT "DEC. "; INT (DC);" "; INT ((DC - INT (DC
)) * 600) / 10
2500 IF DB = 1 THEN VTAB 16: HTAB 32: PRINT "-":DB = 0
2510 REM SATURN
2520 IF SA = 0 THEN 2640
2530 A = A6:P = P6:E = E6:PE = U6:EZ = K6:SRD = S6:J = J6:W = W6:ZZ = ZY +
W:C = C6:I = I6
2540 GOSUB 310: IF PL = 1 THEN 2570
2550 F = F6:H = H6:B = RA:G = DC: GOSUB 110
2560 F6 = RA:H6 = DC: GOTO 2640
2570 VTAB 18: HTAB 1: PRINT "SATN D-S. "; INT (RV * 10000) / 10000
2580 VTAB 19: HTAB 7: PRINT "A-S. "; INT (VA * 10000) / 10000
2590 VTAB 20: HTAB 7: PRINT "D-E. "; INT (ED * 10000) / 10000
2600 VTAB 21: HTAB 7: PRINT "R.A. "; INT (RA / 15);" "; INT ((RA - INT
(RA / 15) * 15) * 40) / 10
2610 IF DC < 0 THEN DC = - DC:DB = 1
2620 VTAB 22: HTAB 7: PRINT "DEC. "; INT (DC);" "; INT ((DC - INT (DC)
) * 600) / 10
2630 IF DB = 1 THEN VTAB 22: HTAB 11: PRINT "-":DB = 0
2640 ZY = ZY + DA
2650 IF ZT + ZY > DN THEN 2700
2660 IF PL = 0 THEN 2690
2670 VTAB 23: HTAB 1: PRINT "PRESS RETURN FOR NEXT DISPLAY": GET AS
2680 VTAB 23: HTAB 1: PRINT "
"
2690 GOTO 1830
2700 ZY = 0:DE = 0
2710 PRINT " ";""
2720 INPUT "PRESS ENTER TO START AGAIN";AS
2730 TEXT : RESTORE
2740 GOTO 650
2750 %COLOR= 3
2760 PRINT : INPUT "ENTER FACTOR: 0 OR 1 - 20 ";SC
2770 IF SC < > 0 THEN 2785
2780 RG = 0:LF = 360:BT = - 90:TP = 110:SC = .75: GOTO 2890
2785 IF SC < 1 THEN 2760
2800 PRINT : PRINT "ENTER CENTER COORDINATES": PRINT
2810 PRINT " R.A. DEC.": PRINT
2820 INPUT "HH.HH , DD.DD ";R,D
2830 RG = R * 15 - 139 / SC
2840 LF = R * 15 + 139 / SC
2850 BT = D - 95 / SC
2860 TP = D + 95 / SC
2870 IF RG < 0 THEN RG = RG + 360
2880 IF LF > 360 THEN LF = LF - 360
2890 %GR2
2900 %PLOT 0,0 TO 279,0
2910 %PLOT TO 279,191
2920 %PLOT TO 0,191
2930 %PLOT TO 0,0
2940 READ B,B1,G,G1
2950 B = B * 15 + B1 * .25:G = G + G1 / 60
2960 IF B = 0 AND G = 0 THEN RETURN
2970 GOSUB 210: GOTO 2940
2980 REM PISCES
2990 DATA 1,11,24,19,1,17,27,0,1,18,28,29,1,9,29,49,0,55,28,43,0,47,27,
26,0,53,26,56,1,28,15,5,1,43,8,54,1,59,2,31
3000 DATA 1,39,5,14,1,28,5,53,1,11,7,19,1,0,7,37,0,46,7,19,23,57,6,35,2
3,37,5,21,23,40,1,30,23,25,6,6,23,18,5,6,23,15,3,1,23,24,0,59
3010 REM ARIES
3020 DATA 1,51,19,3,1,52,20,34,2,1,25,42
3030 REM PLEIADIES
3040 DATA 3,42,24,8,3,42,23,57,3,42,24,18,3,43,24,13,3,43,24,24,3,45,23
,57,3,43,23,48
3050 TAURUS
3060 DATA 5,23,28,34,4,39,22,52,5,35,21,7,5,4,18,35,4,33,16,25,4,26,15,
51,4,17,15,31,4,23,17,49,4,26,19,4
3070 REM GEMINI
3080 DATA 6,12,22,31,6,20,22,32,6,41,25,11,7,8,30,20,7,31,32,0,7,42,28,
9,7,17,22,5,7,1,20,39,6,35,16,27,6,42,12,57
3090 REM CANCER
3100 DATA 8,14,9,20,8,18,24,11,8,30,20,37,8,29,18,16,8,42,18,20,8,40,21
,39,8,56,12,3,8,44,28,57
3110 REM LEO
3120 DATA 9,43,24,0,9,50,26,15,10,14,23,40,10,17,20,6,10,5,17,0,10,6,12,
13,11,11,20,48,11,47,14,51,11,12,15,42

```

3130 REM VIRGO
 3140 DATA 11,43,6,49,11,48,2,3,12,17,-0,-23,12,39,-1,-11,12,53,3,40,13,
 0,11,14
 3200 DATA 13,7,-5,-16,13,23,-10,-54,14,13,-5,-46,14,40,-5,-27,14,44,2,6
 ,13,59,1,47,13,32,-0,-20
 3270 REM LIBRA
 3280 DATA 14,48,-15,-50,15,10,-19,-28,15,14,-9,-12,15,33,-14,-37
 3320 REM SCORPIUS
 3330 DATA 15,57,-22,-29,16,3,-19,-40,16,18,-25,-28,16,28,-26,-19,16,33,
 -28,-7,16,47,-34,-12,16,48,-37,-58,16,50,-42,-17
 3420 DATA 17,9,-43,-11,17,34,-42,-58,17,44,-40,-7,17,39,-39,-0,17,30,-3
 7,-4
 3470 REM SAGITTARIUS
 3480 DATA 18,3,-30,-26,18,14,-36,-47,18,21,-34,-25,18,18,-29,-51,18,25,
 -25,-27,18,43,-27,-3,18,52,-26,-22,18,59,-29,-57,19,4,-27,-45
 3570 REM CAPRICORNUS
 3580 DATA 20,15,-12,-40,20,24,-18,-23,20,36,-15,-8,21,3,-17,-26,21,19,-
 17,-3,21,37,-16,-53,21,44,-16,-21
 3650 DATA 21,40,-19,-6,21,34,-19,-41,21,26,-22,-2,21,24,-22,-38,21,4,-2
 5,-12,20,49,-27,-6,20,43,-25,-27
 3720 REM AQUARIUS
 3740 DATA 22,3,-0,-34,22,23,1,7,22,26,-0,-17,22,33,-0,-23,22,50,-7,-51,
 22,47,-13,-51,22,52,-16,-5,23,12,-6,-19,23,13,-9,-22,23,16,-9,-53,23
 ,40,-14,-49
 3830 REM END OF TABLE (ZEROS)
 3840 DATA 0,0,0,0

]

Othello

by Charles F. Taylor, Jr.

This program simulates the popular board game Othello. Designed for two players, the program maintains the Othello board on the Apple lo-res graphics screen. Written in Applesoft BASIC, Othello should be easily modifiable to other dialects of BASIC.

Most computer game programs are designed for one user. The computer plays the role of opponent, scorekeeper, referee, and manager of the display. This results in a "man-against-machine" scenario. The objective is to "beat the computer" and thereby establish your intellectual superiority over silicon circuitry. (Never mind that you are really playing against an algorithm designed by another person.)

This game program is designed for two persons. The computer no longer is the opponent, but plays the role of slave, keeping track of the board position, checking for illegal moves, keeping score, and managing the display.

Background

I wrote this program for my ten-year-old son. Othello is a good game for interaction across the generation gap because it is more than challenging enough for me, but not too difficult for my son. He beats me more often than I care to admit!

Perhaps the best way to describe the game of Othello is to describe how it is played as a board game, without the aid of the computer. The playing board is eight squares by eight squares, much like a checker or chess board, except that all squares are usually the same color. The playing pieces are disks, black on one side and white on the other. Each player starts with 32 pieces; one player is designated "white" and the other "black."

The game begins with two pieces of each color in the center of the board in the configuration shown in figure 1. White has the first turn. He must place a white piece (a piece with the white side up) in such a manner as to "capture" a black piece. A piece is captured when it is "surrounded" by pieces of the opposite color, either horizontally, vertically, or diagonally. Captured pieces are turned over and become the color of the captor. More than one piece can be captured at a time.

Figure 2 illustrates the capture of two black pieces by a white piece. A move is not legal unless it accomplishes one or more captures. The game is won by either capturing all of your opponent's pieces, or by having more pieces than your opponent at the end of the game.

Implementation

The program was written in Applesoft BASIC on an Apple II Plus. Low-resolution graphics are used to display the game board, thus pieces are shown as square rather than round. The selection of colors is easily changed to suit your own display (see lines 280 - 300). I am currently using a "green screen" monitor and find it hard to judge colors as they might appear on another display.

The program is shown in listing 1. The coding is straightforward, but perhaps a few comments are in order. The board is represented internally by the array "BOARD." The function "FN M2(Q)" finds the modulus base 2 of a number (the remainder after integer division by 2) and is used to compute whose turn it is. The legality of each move is checked. The subroutine at 1430 searches for and executes all possible captures, beeping for each capture. The score is displayed after each move.

Play

To move, a player types the row and column where he wants to place his piece. Columns are labeled A-H, left to right; rows are labeled 1-8, bottom to top. The lower left corner is then A1, the lower right corner H1, and so on. Should you ever find yourself in a position such that no legal moves are possible, type "P" for "Pass." Play tends to ebb and flow like the tides, but without any predictability. A player can be comfortably ahead at one moment and hopelessly behind the next.

Figure 1

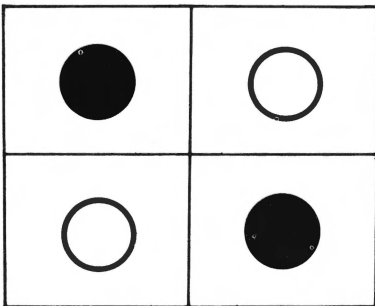
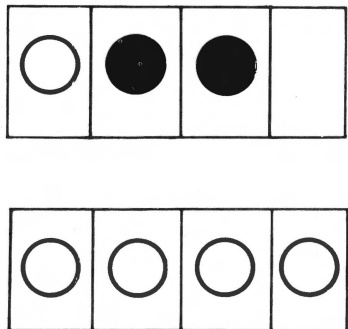

Figure 2



```

1  REM *****
2  REM *
3  REM *   GAME OF OTHELLO   *
4  REM *   C.F. TAYLOR     *
5  REM *
6  REM *   COPYRIGHT (C) 1982 *
7  REM *   MICRO INK, INC.   *
8  REM *   CHELMSFORD, MA 01824 *
9  REM *   ALL RIGHTS RESERVED *
10 REM *
11 REM *****
12 REM
13 REM
14 REM
15 REM INITIALIZE
16 DIM BOARD(9,9)
17 DIM CC(2): REM HOLDS CURRENT COLOR
18 DIM PROMPT$(2)
19 DIM SC(2)
20 DIM DX(8): DIM DY(8)
21 DEF FN M2(Q) = Q - INT (Q / 2) * 2
22 PROMPT$(1) = "INPUT WHITE MOVE:"
23 PROMPT$(2) = "INPUT BLACK MOVE:"
24 BLACK = 0
25 WHITE = 15
26 CC(1) = WHITE
27 CC(2) = BLACK
28 BC = 12: REM BACKGROUND COLOR
29 TC = 13: REM TITLE COLOR
30 DC = 4: REM BORDER COLOR
31 DATA 0,1,1,1,0,-1,-1,-1
32 DATA 1,1,0,-1,-1,-1,0,1
33 FOR I = 1 TO 8: READ DX(I): NEXT I
34 FOR I = 1 TO 8: READ DY(I): NEXT I
35 FOR I = 0 TO 9
36 FOR J = 0 TO 9
37 BOARD(I,J) = 0
38 NEXT J,I
39 GOSUB 78
40 COLOR= WHITE
41 X = 5:Y = 5
42 BOARD(X,Y) = 1
43 GOSUB 126: REM CALL BLOT
44 X = 4:Y = 4
45 BOARD(X,Y) = 1
46 GOSUB 126: REM CALL BLOT
47 SC(1) = 2
48 COLOR= BLACK
49 X = 4:Y = 5
50 BOARD(X,Y) = 2
51 GOSUB 126: REM CALL BLOT
52 X = 5:Y = 4
53 BOARD(X,Y) = 2
54 GOSUB 126: REM CALL BLOT
55 SC(2) = 2
56 TURN = 2
57 REM BEGIN MAIN LOOP
58 FOR Q = 1 TO 100
59 TURN = FN M2(TURN) + 1
60 COLOR= CC(TURN)
61 PRINT "SCORE IS: WHITE ";SC(1);" BLACK ";SC(2)
62 PRINT PROMPT$(TURN)
63 GOSUB 133: REM CALL GETMOVE
64 IF PASS THEN 70
65 IF BOARD(X,Y) < > 0 THEN 62
66 GOSUB 143: REM CALL MOVES
67 IF FLAG = 0 THEN 62
68 IF ((SC(1) + SC(2)) = 64) THEN 71
69 IF ((SC(1) = 0) OR (SC(2) = 0)) THEN 71
70 NEXT Q
71 IF SC(1) > SC(2) THEN PRINT "WHITE WINS!": GOTO 74
72 IF SC(1) < SC(2) THEN PRINT "BLACK WINS!": GOTO 74
73 PRINT "IT'S A TIE!!"
74 PRINT "FINAL SCORE: WHITE ";SC(1);" BLACK ";SC(2)
75 INPUT "WOULD YOU LIKE TO PLAY AGAIN?";A$

```

```

76 IF LEFT$(A$,1) = "Y" THEN 35
77 END
78 REM SUBROUTINE TO DRAW OTHELLO BOARD
79 GR
80 COLOR= BC
81 FOR I = 0 TO 39
82 HLIN 1,39 AT I
83 NEXT I
84 COLOR= TC: REM TITLE COLOR
85 REM PLOT "OTHELLO"
86 REM FIRST "O"
87 VLIN 1,5 AT 7
88 PLOT 8,1
89 PLOT 8,5
90 VLIN 1,5 AT 9
91 REM NEXT "T"
92 HLIN 11,13 AT 1
93 VLIN 2,5 AT 12
94 REM NEXT "H"
95 VLIN 1,5 AT 15
96 PLOT 16,3
97 VLIN 1,5 AT 17
98 REM NEXT "E"
99 VLIN 1,5 AT 19
100 HLIN 20,21 AT 1
101 PLOT 20,3
102 HLIN 20,21 AT 5
103 REM NEXT TWO "L"S
104 VLIN 1,5 AT 23
105 HLIN 24,25 AT 5
106 VLIN 1,5 AT 27
107 HLIN 28,29 AT 5
108 REM FINALLY ANOTHER "O"
109 VLIN 1,5 AT 31
110 PLOT 32,1
111 PLOT 32,5
112 VLIN 1,5 AT 33
113 REM NOW DO BOARD ITSELF
114 COLOR= DC: REM BORDER COLOR
115 FOR I = 7 TO 39 STEP 4
116 HLIN 4,36 AT I
117 NEXT I
118 FOR I = 4 TO 36 STEP 4
119 VLIN 8,38 AT I
120 NEXT I
121 RETURN
122 REM SUBR MAP FINDS SCREEN COORDS (XS,YS) GIVEN BOARD COORDS (X,Y)
123 XS = 1 + 4 * X
124 YS = 40 - 4 * Y
125 RETURN
126 REM SUBR BLOT FILLS IN A SQUARE WITH THE CURRENT COLOR
127 GOSUB 122
128 X2 = XS + 2
129 HLIN XS,X2 AT YS
130 HLIN XS,X2 AT YS + 1
131 HLIN XS,X2 AT YS + 2
132 RETURN
133 REM SUBR GETMOVE
134 INPUT MOVES
135 PASS = 0
136 IF LEFT$(MOVES,1) = "P" THEN PASS = 1: RETURN
137 IF LEN (MOVES) < > 2 THEN 134
138 X = ASC ( LEFT$(MOVES,1)) - 64
139 IF X < 1 OR X > 8 THEN 134
140 Y = ASC ( RIGHT$(MOVES,1)) - 48
141 IF Y < 1 OR Y > 8 THEN 134
142 RETURN
143 REM FIND AND EXECUTE MOVES
144 FLAG = 0
145 OP = 3 - TURN: REM COLOR OF OPPONENT
146 FOR I = 1 TO 8
147 NR = 0
148 XN = X:YN = Y
149 XN = XN + DX(I):YN = YN + DY(I)
150 IF BOARD(XN,YN) = OP THEN NR = NR + 1: GOTO 149

```

```
151 IF (BOARD(XN,YN) = 0) OR (NR = 0) THEN 170
152 REM IF WE GET HERE, CAPTURE IS POSSIBLE
153 FLAG = 1
154 COLOR= CC(TURN)
155 IF BOARD(X,Y) < > 0 THEN 159
156 GOSUB 126: REM CALL BLOT
157 BOARD(X,Y) = TURN
158 SC(TURN) = SC(TURN) + 1
159 FOR J = 1 TO NR
160 XN = XN - DX(I):YN = YN - DY(I)
161 BOARD(XN,YN) = TURN
162 XTEMP = X:YTEMP = Y
163 X = XN:Y = YN
164 GOSUB 126: REM CALL BLOT
165 X = XTEMP:Y = YTEMP
166 PRINT CHR$( 7)
167 SC(TURN) = SC(TURN) + 1
168 SC(OP) = SC(OP) - 1
169 NEXT J
170 REM
171 NEXT I
172 RETURN
```

Musical Duets

by Rick Brown

Music generated by the Apple II, without extra firmware, is usually limited to one voice. Here are two Applesoft programs which, with the help of an ordinary amplifier, add a new dimension to Apple music — harmony.

Anyone who has ever done any serious game-playing on the Apple II surely realizes how a catchy tune played through the Apple's speaker can enhance a program. A short machine language program is all that is needed to generate notes with a wide range of frequencies and durations. Such a tone-generating program is very nice, but it only generates one voice, which is to say, only one note at any given time can be played through the speaker. The usual way to acquire extra voices is to open the piggy bank and buy a music board or some other peripheral device designed for synthesizing music. For the serious music lover, it may be that nothing less will do. But can anything be done to satisfy the rest of us, whose standards (or finances) may not be as high? I chose to try to add, through software, a second voice to the Apple.

Now, before we go further, a little information about how a tone-generating program works is in order. The assembly language instruction LDA \$C030 will toggle the Apple's speaker once every time it is executed, resulting in a little "click." Any sound whatsoever coming from the speaker is nothing but a series of such clicks, and the nature of the sound depends only on the interval of time between one click and the next. In the simplest case, this time interval is constant, and a steady, single-frequency, "pure" tone is generated. One convenient way to control the length of the pause between clicks is to use a "do-nothing" loop in the program, which generates a pause that is proportional to the number of times the loop is executed. The longer the pause between clicks, the lower the frequency of the resultant tone.

It occurred to me that it might be possible, by interleaving two such "do-nothing" loops, to superimpose one tone upon another and thus create the Apple's second voice. Consider two tones, one with a frequency of 500 Hz, and the other with a frequency of 300 Hz. To generate the first, we make the speaker click at intervals of 0.002s (s = seconds); that is, at these instants: 0,000s, 0.002s, 0.004s, 0.008s, 0.010s, etc.

Similarly, the 300 Hz tone would click at these instants: 0.0000s, 0.0033s, 0.0067s, 0.0100s, etc. Now, to generate both tones simultaneously, we should (it would seem) click the speaker at these instants: 0s, 0.002s, 0.0033s, 0.004s, 0.0067s, 0.008s, 0.01s, and so on. The problem of the two tones "clicking" at the same instant (e.g., at 0s and at 0.01s) is taken care of by a sort of "phase shift" inherent in the way the two "do-nothing" loops are interleaved.

Well, it all looks good on paper, and it might even work, were we using sinusoidally varying pulses instead of instantaneous clicks. But in fact, what results from the above technique is one of the most awful noises I've ever heard coming from the Apple speaker.

A More Promising Technique

All is not lost. There is another assembly language instruction, LDA \$C020, which toggles not the speaker, but the cassette output. This produces a "click" on a cassette recording. Or, if the output jack is connected to an amplifier, an audible click is produced. This is the secret to the second voice. There are several ways to amplify the signal. Perhaps the simplest is to plug an external speaker into your cassette recorder, and set the recorder in the "record" mode. Then, any input to the microphone jack will be amplified through the external speaker. Alternatively, you could patch from the cassette output jack to the computer to the auxiliary input of a stereo set. This method will probably give you more control over volume and tone. Now, by clicking the Apple speaker at a fixed interval, and clicking the alternate speaker at a different fixed interval, we can produce two distinct simultaneous tones. The Apple now harmonizes with itself!

Making Music

The core of the programs presented here is a machine language routine which generates two simultaneous notes of different pitches (P1 and P2), and different durations (D1 and D2). These notes are stored in two tables: one contains the melody and the other contains the harmony. After a note (either melody or harmony) is completed, the routine fetches the next pitch and duration from the appropriate table, and plays the next note. When a duration of zero is encountered in either table, the song is considered to be complete, and the machine language routine terminates. A listing of this routine is given in figure 1.

For each note, the pitch and duration take up one byte apiece. Thus there are 256 variations of pitch, and 255 possible durations (recall that a duration of zero will end the song). The value of P (the pitch) is proportional to the time delay between two successive "clicks" of the speaker, so that the highest values of P will produce the lowest notes. Because of this, P should be considered proportional to the wavelength, rather than to the frequency, of the note.

Although we have 256 wavelengths to choose from, most of them produce notes which are "between the keys of a piano." In other words, in order to make use of the isotonic scale to which we are accustomed, and in which music is commonly written, we must use only twelve notes per octave, and discard those values of P which produce non-isotonic notes. The range of 256 wavelengths available to us covers exactly eight octaves. The maximum number of isotonic notes we can use is 8×12 , or 96. (In practice, the number is limited still further, as explained below.)

The ratio of wavelengths of two consecutive notes on the isotonic scale is a constant $2^{1/12}$, or about 1.059, so that the ratio of wavelengths of two notes an octave apart is always 2:1. Thus wavelengths 128 and 64 are an octave apart, as are wavelengths 20 and 10, 2 and 1, and so forth. This fact imposes an obvious limitation on the higher notes.

Suppose we have a very high note — say of wavelength 4. The note one octave higher, then, has a wavelength of 2. Now, since the program uses only integers to represent wavelengths, it cannot generate the 11 isotonic notes between these two wavelengths (in fact, it can only generate one, corresponding to wavelength 3).

Another problem arising out of the use of integers for wavelengths is that the higher notes have an unavoidable tendency to go off-key. Suppose that the exact isotonic wavelength of a particular note (a low note, in this example) is calculated to be 154.43 on a scale from 1 to 256. This is rounded off to 154, creating a relative error of 0.29%. Consider now, a much higher note, whose exact wavelength is 15.43. This is rounded to 15, causing a much higher relative error of 2.8%, and it is this *relative* error (rather than the absolute error), which is detected by the ear.

Taking into account the limitations discussed earlier, I designed the program to use the lowest 65 isotonic notes available, covering a little more than five octaves, and using wavelengths from 6 to 256 (the latter wavelength is represented by zero in the routine). The highest notes are still a bit off-key, but generally they are rarely used and won't create much of a problem. As far as the durations of the notes are concerned, they remain, as far as the ear can tell, faithfully proportional to their numerical values, throughout the range from 1 to 255.

The two programs presented here can be used to play duets. However, the main purpose of the first program is to assemble the note tables from the data input by the user and to save the song on disk, while the second program is used only to load and play previously-recorded songs.

The Note-Table Assembler Program

This program provides an easy way to input a song, listen to it, edit it according to taste, and finally to save it on disk for later use. The song is input to the program through the use of DATA statements, which are typed in by the user each time the program is run. All such DATA statements must have line numbers greater than 696. The elements in these DATA statements will indicate the key

signature (if any), the name and relative duration of each note, and the end of each part (melody or harmony) of the song. There are also special DATA elements which indicate that a particular part of the song is to be repeated. To facilitate the entry of these data, the notes are called by their alphabetic names (A,B,C,D,E,F,G) and converted by the program to the appropriate numerical values. The key signature, by default, determines whether a given note is to be played sharp, flat, or natural, but the signature may be overridden by appending the character “#” (sharp), “&” (flat), or “N” (natural) to the note’s name.

Notes of different octaves are indicated by a single digit appended to the note name. If no such digit appears, octave 0 (zero) is assumed (this is the lowest octave which can be notated). Thus, G3 is one octave above G2, and D#1 is one octave above D#. The lowest letter-name within an octave is A, and the highest is G. Thus A2 is just a little above G1, while G#4 and A&5 designate the same note. A detailed description of the formats of the data elements follows:

1. *Key Signature (optional)*: If the music is written in a key other than C, the first two data elements should indicate the key signature. The first element should consist of the word “SHARP” or “FLAT”, and the second element should be a string consisting of the letter names (in any order) of the notes to be sharpened or flattened. Example:

730 DATA FLAT,ADBE

2. *Note Names*: Each note name is an alphanumeric data item of the form XYM, where:

X is one of the letters A, B, C, D, E, F, G, or R (rest)...

Y is an optional character indicating sharp (#), flat (&), or natural (N). Any of these characters will override the key signature...

M is a number from 0 to 9, indicating which octave the note belongs to. (However, the range within one song is limited to 65 notes, or about 5½ octaves.) M can be omitted if it equals zero.

If X equals “R”, then Y and M are omitted. Each note name must be followed by its note-duration.

3. *Note Duration*: This is a numerical quantity indicating the *relative* duration of the note that precedes it (the absolute duration will be calculated later). For example, if a quarter-note is given a duration of 1, then a half-note would have a duration of 2, etc. Example:

740 DATA F1,.5,F#1,1,R,2,BN,1.5

4. *Repeat Flags*: An asterisk followed by a single digit is a repeat flag. Repeat flags should be placed at the beginning and end of any segment of the song which is to be repeated. Repeat flags do not actually initiate a repetition, but merely

serve as pointers which the REPEAT keyword (see below) can refer to. The repeat flags marking the beginning and end of the segment must contain different digits. Example:

```
850 DATA G,3,*1,F,2,D,2,A,1,*2
```

5. *Repeat*: When the word REPEAT is used in a DATA statement, it indicates that all the notes between some pair of previous repeat flags are to be repeated. The two DATA elements following REPEAT must be single-digit integers indicating which two of the preceding repeat flags delimit the segment to be repeated. For example,

```
800 DATA REPEAT,2,5
```

will cause everything between flags *2 and *5 (including, possibly, other REPEATs) to be repeated, assuming flags *2 and *5 have occurred as previous DATA elements. A particular repeat flag may appear in several places without error; a REPEAT command referring to that flag will always use the most recent occurrence.

6. *END1*: In a duet, the data element "END1" must follow the first part (melody) of the song.
7. *Second Part*: Note names and durations for the second part (harmony) of the song must follow "END1", in the format indicated in 2 and 5. The key signature (if any) is still in effect and should not be repeated here.
8. *END2*: The DATA element "END2" must follow the second part (harmony) of the song.

The above format applies to duets. There is also an option for entering and playing 1-part solos. To do this, enter key signature, note names, note durations and REPEAT specifications for one part, as described above, but following the last note duration, enter the string "ENDSOLO" as the last data element. This will cause the same tune to be played through both speakers. Figure 2 has been included on disk under the name "BROWN NOTES" and can be EXEC'ed into the Note-Table Assembler program.

Running the Program

Before running the program as shown, you may find it necessary to change the value of M in line 10. HIMEM will be set to this value, which will be the highest byte occupied by the note tables, plus 1. The value shown in the listing is for a 48K system without DOS. Modify line 10 if necessary, then save the program on disk as shown (without any DATA statements).

Now, each time you load the program, type in the DATA statements according to the format explained above, remembering to give them line numbers higher

than 696. Caution: for alphanumeric data, trailing blanks are considered to be part of the string, and may cause the data to be misinterpreted by the program. Avoid trailing blanks!

After all the necessary DATA statements have been entered, type "RUN". In a few seconds, you will see the prompt "TEMPO,KEY?" The tempo you input will be proportional to the *length* of the song, so that higher values will actually produce slower music. Notice that this is opposite from the usual interpretation of tempo. The tempo is multiplied by the relative note duration obtained from the DATA statement, the product is rounded to the nearest integer, and the final value is POKed into the note table. So, for best results, you should input a tempo which, when multiplied by the note duration, always yields an integer (thus avoiding any rounding error). In no case may the product of the tempo and the relative note duration exceed 255. A product of 255 will produce a note about 3.0 seconds long. All other durations are proportionally shorter.

The KEY is an integer value (positive, negative, or zero) indicating how many semitones the song will be shifted up or down on the isotonic scale. Thus, for example, a key of 22 is one octave (12 semitones) higher than a key of 10. If the input key causes any note to fall outside the available range of 65 notes, an error message will be given.

After the tempo and key have been input, the program begins assembling the note tables. As the program processes the DATA statements, error or warning messages may be given, generated either by the program or by Applesoft. These messages are described in detail in table 1.

Program Commands

After the note tables are assembled, you will be prompted with a question mark. In response to this, you may type one of the following commands:

GO plays the song, in harmony and stereo, with as many repetitions as desired. (Be sure your amplifier is properly connected.)

SWAP causes parts 1 and 2 to switch speakers. Before this command is executed, part 1 plays through the Apple speaker, part 2 through your amplifier. Another SWAP will restore the original speakers.

CHANGE allows you to change the tempo and key, and reassemble the note tables.

EDIT lists the DATA statements and ends the program, allowing you to modify the song.

SAVE requests a song title, then saves the note tables on disk. Since the program uses the GET command to input the title, any characters may be input, including colons, commas, and quotes. A carriage return terminates the input and causes recording instructions to be displayed.

Table 1: Error/Warning Messages

MESSAGE	PROBABLE CAUSE
ILLEGAL QUANTITY ERROR	Tempo = 0
BAD SUBSCRIPT ERROR	Illegal note name in DATA statement
OUT OF DATA ERROR	No "END2", or no "ENDSOLO"
SYNTAX ERROR	Bad DATA statement format; data type mismatch
ERROR: KEY IS TOO HIGH	} Key would cause notes to be outside of allowable range
ERROR: KEY IS TOO LOW	
ERROR: TEMPO IS TOO LONG	Tempo * Relative Duration > 255 for some note
ERROR: INSUFFICIENT MEMORY FOR NOTE TABLES	DATA statements plus note tables take up too much memory
WARNING: PART X IS XXX UNITS SHORTER THAN PART X. SONG WILL END EARLY.	The sums of the durations obtained from the DATA statements do not match. Song will play up to the end of the shorter part.
WARNING: DURATIONS OF SOME NOTES WERE ROUNDED TO THE NEAREST INTEGER. TUNES MAY NOT BE SYNCHRONIZED.	Tempo * Relative Duration does not equal an integer for some note(s).

The Playback Program

After I wrote the program just described (the first version of which did not include the SAVE command), it occurred to me that you could spend a lot of time in putting a masterpiece, and lose it all when the computer was turned off. Of course, it's always possible to save the entire program, and thus preserve the DATA statements, but this can run into a lot of disk space if you make a habit of it. Another drawback of this method is that every time the program is reloaded, the note tables have to be re-assembled, a process which can take several minutes for long songs. With all this in mind, I added the SAVE feature to the note-table assembler program, and wrote another program whose sole purpose was to load and play previously recorded songs. Since this playback program loads note tables which are already assembled, we do not experience the delay associated with assembling, and of course a lot of time and tape is saved for anyone who wants to build up a library of songs.

As can be seen from the listing, line 10 of this program is the same as line 10 of the note-table assembler program. If necessary, modify this line as previously described before running the program.

In line 180, ET is set to the beginning address of the file BLOADED in line 130. The addresses PEEKed in line 180 are for a 48K system. The correct addresses for a smaller system can be found on page 144 of the DOS 3.3 manual.

After typing "RUN", you will be prompted with a question mark. In response to the question mark, any of the following commands can be typed:

GO plays the song. Same as the GO command described earlier.

SWAP switches the speakers. Same as the SWAP command described earlier.

CAT prints a catalog of the files on the disk.

LOAD allows you to load and play another song from disk.

Note that there are no CHANGE or EDIT commands here; this is a "read-only" type program. When running the first program, then, you should be sure the tempo and key are adjusted to their most pleasing values before SAVEing the song.

A Sample Song

In figure 2, the DATA statements for a short song are given. This is a folk song entitled "Blue Bells of Scotland." The recommended tempo and key for this song are 30, 20. These DATA statements illustrate several techniques which come in handy when you're inputting a song:

1. Input one measure per DATA statement. This way, if you get a warning that the two parts are not of the same length, you can simply check each DATA statement until you find the measure that doesn't "add up." This technique also helps you to relate the DATA statements to the sheet music.

2. Choose note durations which will take the least amount of typing. In this example, quarter notes are represented by 1, and eighth notes by .5. If a song contains a preponderance of eighth notes, on the other hand, it might be wiser to represent eighth notes by 1, and quarter notes by 2, etc., so that you would not have to type in so many decimal points. This would simply require a corresponding adjustment in the TEMPO when the program is run.

3. Number the DATA statements so that a measure in the melody can be easily related to the corresponding measure in the harmony. In the example, DATA statements of corresponding measures have line numbers separated by 100.

The Applesoft programs described provide a convenient method for transferring a song from sheet music to the computer. However, the assembly language routine can be used independently, as long as note tables are created, and the

pointers to the beginnings of the note tables are initialized. Thus it is possible to experiment with more exotic kinds of music, using all 256 wavelengths instead of just the 65 to which my note-table assembler is limited. CALL 777 will start the song playing. If the song is interrupted (as with a RESET), CALL 840 will cause it to pick up where it left off.

Figure 2: Blue Bells of Scotland

```

800 DATA G,1
801 DATA *1,C1,2,B1,1,A1,1
802 DATA G,2,A1,1,B1,.5,C1,.5
803 DATA E,1,E,1,F,1,D,1
804 DATA C,3,*2,G,1
805 DATA REPEAT,1,2,G,1
806 DATA E,1,C,1,E,1,G,1
807 DATA C1,2,A1,1,B1,.5,C1,.5
808 DATA B1,1,G,1,A1,1,F#,1
809 DATA G,2,A1,1,B1,1
810 DATA REPEAT,1,2
811 DATA END1
900 DATA R,1
901 DATA *3,R,1,E,1,*4,F,1,F,1
902 DATA E,2,F,2
903 DATA G,1,C,1,D,1,F,1
904 DATA E,3,*5,R,1
905 DATA REPEAT,3,5,R,1
906 DATA C1,3,D1,1
907 DATA A1,2,F,1,G,.5,A1,.5
908 DATA D1,2,C1,2
909 DATA B1,1,D1,1,G,1,F,1
910 DATA E,2,REPEAT,4,5
911 DATA END2

```

When you create the note tables "by hand", (without the aid of the note-table assembler program), follow the structure illustrated in figure 3, POKEing the first note into the *highest* memory location, and working your way down. The first pointer (decimal locations 773,774) should be set to the location of the first pitch of the first part, *plus one*. Similarly, the second pointer (decimal locations 775,776) should be set to the location of the first pitch of the *second* part, plus one. In the case of solos, the first part *is* the second part, so both pointers are set to the same location. By judicious placement of these pointers, you can play duets, play solos, create a short delay between the two speakers for an "echo" effect, or even "listen" to the computer's ROM. For another interesting effect, execute the following instruction:

POKE 835,80 – PEEK(835)

Then, when you do a CALL 777, both parts of the song will be sent through the same speaker. This will provide an excellent demonstration of why I chose to use two speakers instead of one.

Whether you use the machine language routine independently, or with the programs described in this article, or within your own BASIC programs, there is plenty of room for experimentation.

Figure 3: Structure of Note Tables for Duets

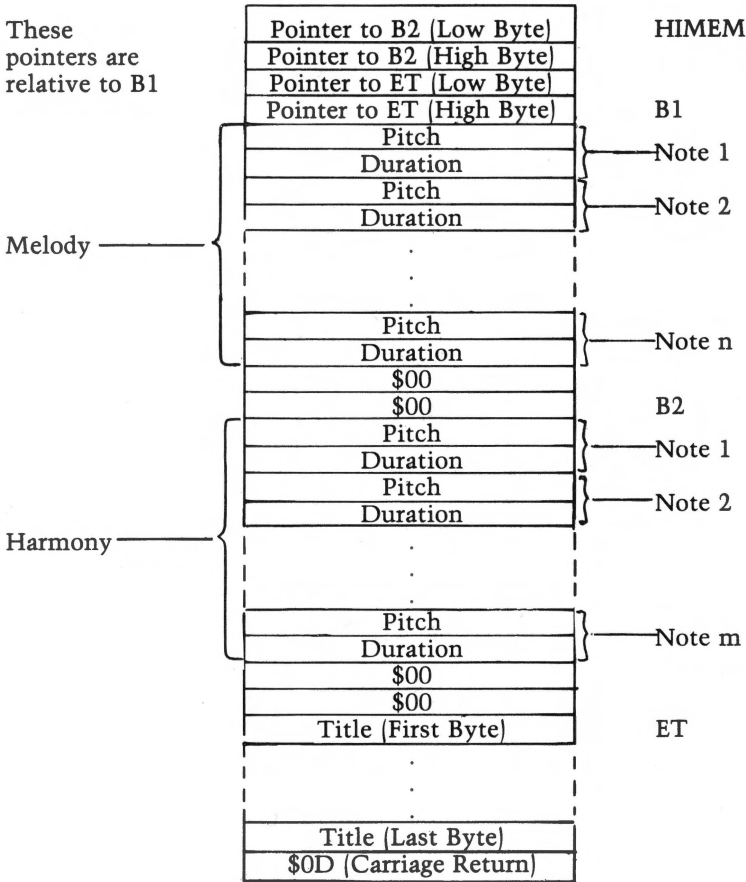

```

0800      1  ;*****
0800      2  ;*
0800      3  ;* 2-TONE GEN. ROUTINE *
0800      4  ;*      RICK BROWN *
0800      5  ;*
0800      6  ;*      TONE GEN *
0800      7  ;*
0800      8  ;*  COPYRIGHT (C) 1982 *
0800      9  ;*      MICRO INK, INC. *
0800     10  ;*  CHELMSFORD, MA 01824 *
0800     11  ;*  ALL RIGHTS RESERVED *
0800     12  ;*
0800     13  ;*****
0800     14  ;
0800     15  ;
0006     16  INDX1L  EPZ $06
0007     17  INDX1H  EPZ $07
0008     18  INDX2L  EPZ $08
0009     19  INDX2H  EPZ $09
0800     20  ;
0800     21  ;
0300     22  I      EQU $300
0301     23  P1     EQU $301
0302     24  D1     EQU $302
0303     25  P2     EQU $303
0304     26  D2     EQU $304
0305     27  I1L    EQU $305
0306     28  I1H    EQU $306
0307     29  I2L    EQU $307
0308     30  I2H    EQU $308
0800     31  ;
0800     32  ;
0309     33      ORG $309
0309     34      OBJ $800
0309     35  ;
0309 AD 05 03 36      LDA I1L      ; INITIALIZE
030C 85 06 37      STA INDX1L   ; POINTERS
030E AD 06 03 38      LDA I1H      ; TO
0311 85 07 39      STA INDX1H   ; BEGINNING
0313 AD 07 03 40      LDA I2L      ; ADDRESSES
0316 85 08 41      STA INDX2L   ; OF
0318 AD 08 03 42      LDA I2H      ; NOTE
031B 85 09 43      STA INDX2H   ; TABLES
031D A9 00 44      LDA #$00
031F 8D 00 03 45      STA I
0322 20 60 03 46      JSR READ1     ; FETCH FIRST NOTE OF MELODY
0325 20 84 03 47      JSR READ2     ; FETCH FIRST NOTE OF HARMONY
0328 CA 48      LBL1     DEX
0329 FO 07 49      BEQ TONE1
032B EA 50      NOP      ; THESE TWO INSTRUCTIONS CAUSE
032C AD 11 11 51      LDA $1111     ; A 6-CYCLE TIME DELAY
032F 4C 38 03 52      JMP LBL2
0332      53  ;
0332 AD 30 C0 54      TONE1    LDA $C030     ; CLICK SPEAKER AFTER P1 LOOPS
0335 AE 01 03 55      LDX P1      ; RESET X-REGISTER
0338 88 56      LBL2     DEY
0339 FO 07 57      BEQ TONE2
033B EA 58      NOP      ; THESE TWO INSTRUCTIONS CAUSE
033C AD 11 11 59      LDA $1111     ; A 6-CYCLE TIME DELAY
033F 4C 48 03 60      JMP LBL3
0342      61  ;
0342 AD 20 C0 62      TONE2    LDA $C020     ; CLICK SPEAKER AFTER P2 LOOPS
0345 AC 03 03 63      LDY P2      ; RESET Y-REGISTER
0348 CE 00 03 64      LBL3     DEC I      ; AFTER 256 LOOPS, CHECK FOR EN
D OF NOTES
034B DO DB 65      BNE LBL1
034D CE 02 03 66      DEC D1      ; END OF MELODY NOTE?
0350 DO 03 67      BNE LBL4     ; NO, CHECK HARMONY NOTE
0352 20 60 03 68      JSR READ1     ; YES, FETCH NEXT NOTE OF HARMO
NY
0355 CE 04 03 69      LBL4     DEC D2      ; END OF HARMONY NOTE?
0358 DO CE 70      BNE LBL1     ; NO, LOOP AGAIN
035A 20 84 03 71      JSR READ2     ; YES, FETCH NEXT NOTE OF HARMO
NY
035D 4C 28 03 72      JMP LBL1      ; THEN LOOP AGAIN

```

```

0360          73 ;
0360 A2 00    74 READ1 LDX #$00
0362 A5 06    75      LDA INDX1L
0364 D0 02    76      BNE LBL5
0366 C6 07    77      DEC INDX1H
0368 C6 06    78 LBL5  DEC INDX1L
036A A1 06    79      LDA (INDX1L,X)
036C 8D 01 03 80      STA P1
036F A5 06    81      LDA INDX1L
0371 D0 02    82      BNE LBL6
0373 C6 07    83      DEC INDX1H
0375 C6 06    84 LBL6  DEC INDX1L
0377 A1 06    85      LDA (INDX1L,X)
0379 8D 02 03 86      STA D1          ;DURATION OF MELODY NOTE
037C D0 02    87      BNE LBL7
037E 68      88      PLA          ;IF D1=0, POP RETURN ADDRESS
037F 68      89      PLA          ;OFF STACK, SO RTS WILL END PR
OGRAM
0380 AE 01 03 90 LBL7  LDX P1
0383 60      91      RTS
0384          92 ;
0384 A0 00    93 READ2  LDY #$00
0386 A5 08    94      LDA INDX2L
0388 D0 02    95      BNE LBL8
038A C6 09    96      DEC INDX2H
038C C6 08    97 LBL8  DEC INDX2L
038E B1 08    98      LDA (INDX2L),Y
0390 8D 03 03 99      STA P2          ;PITCH (WAVELENGTH) OF HARMONY
NOTE
0393 A5 08    100     LDA INDX2L
0395 D0 02    101     BNE LBL9
0397 C6 09    102     DEC INDX2H
0399 C6 08    103 LBL9  DEC INDX2L
039B B1 08    104     LDA (INDX2L),Y
039D 8D 04 03 105     STA D2          ;DURATION OF HARMONY NOTE
03A0 D0 02    106     BNE LBL10
03A2 68      107     PLA          ;IF D2=0, POP RETURN ADDRESS
03A3 68      108     PLA          ;OFF STACK, SO RTS WILL END PR
OGRAM
03A4 AC 03 03 109 LBL10 LDY P2
03A7 60      110     RTS
03A8          111     END

```



```

0 REM *****
1 REM *
2 REM * NOTE-TABLE ASSEMBLER *
3 REM * RICK BROWN *
4 REM * *
5 REM * COPYRIGHT (C) 1982 *
6 REM * MICRO INK, INC. *
7 REM * CHELMSFORD, MA 01824 *
8 REM * ALL RIGHTS RESERVED *
9 REM *
10 REM *****
11 REM
12 REM
13 M = 38400: REM M=HIGHEST AVAILABLE ADDRESS
20 B1 = M - 4: HIMEM: M
30 DIM N%(65),P%(7),M(10),L(10)
40 DEF FN HI(X) = INT (X / 256)
50 DEF FN LO(X) = X - FN HI(X) * 256
55 REM LOAD MACHINE LANGUAGE PROGRAM
60 PRINT CHR$(4)"BLOOD BROWN/TONE GEN.CODE"
120 N%(0) = 1:N%(1) = 0
125 REM SET ISOTONIC WAVELENGTHS
130 FOR I = 2 TO 65
140 N%(I) = 256 / (2 ^ ((I - 1) / 12)) + .5
150 NEXT I
153 REM ABCDEFG
155 P%(1) = 0:P%(2) = 2:P%(3) = 3:P%(4) = 5
156 P%(5) = 7:P%(6) = 8:P%(7) = 10
160 E = M - FRE (0) - 65536 * ( FRE (0) < 0) + 200: HIMEM: E
165 D$ = CHR$(4)
170 B$ = CHR$(7) + "ERROR: "
180 RESTORE : INPUT "TEMPO,KEY? ";TM,K:L = 0:F1 = 0
190 READ P$: IF P$ = "SHARP" OR P$ = "FLAT" THEN 680
200 RESTORE :LN = 0
210 FOR I = B1 - 1 TO E STEP - 2
220 READ P$: IF LEFT$(P$,3) = "END" THEN 370
230 IF P$ = "R" THEN P = 0: GOTO 330
235 IF LEFT$(P$,1) = "*" THEN MK = VAL ( MID$(P$,2)):M(MK) = I:L(MK)
= L: GOTO 220
237 IF LEFT$(P$,6) = "REPEAT" THEN 692
240 P = P%( ASC (P$) - 64) + 12 * VAL ( RIGHT$(P$,1)) + K%
250 A$ = MID$(P$,2,1)
255 IF A$ = "N" THEN 310
260 IF A$ = "#" THEN P = P + 1: GOTO 310
270 IF A$ = "&" THEN P = P - 1: GOTO 310
280 IF LN = 0 THEN 310
290 FOR J = 1 TO LN
295 IF MID$(SF$,J,1) = LEFT$(P$,1) THEN P = P + Q: GOTO 310
300 NEXT
310 IF P < 1 THEN PRINT B$;"KEY IS TOO LOW": GOTO 180
320 IF P > 65 THEN PRINT B$;"KEY IS TOO HIGH": GOTO 180
330 READ DD:L = L + DD:DD = DD * TM:D = INT (DD + .5)
340 IF D > 255 THEN PRINT B$;"TEMPO IS TOO LONG": GOTO 180
350 IF D < > DD THEN F1 = 1
355 REM POKE PITCH & DURATION INTO NOTE TABLE
360 POKE I,N%(P): POKE I - 1,D: GOTO 390
370 POKE I,0: POKE I - 1,0
375 IF LEFT$(P$,7) = "ENDSOLO" THEN B2 = B1:ET = I - 2:L2 = L1: GOTO 4
00
380 IF LEFT$(P$,4) = "END2" THEN ET = I - 2:L2 = L - L1: GOTO 400
385 B2 = I - 1:L1 = L
390 NEXT I
395 PRINT B$;"INSUFFICIENT MEMORY": PRINT "FOR TUNE TABLES": HIMEM: M: END
400 POKE M - 1, FN LO(B1 - B2): POKE M - 2, FN HI(B1 - B2)
405 POKE M - 3, FN LO(B1 - ET): POKE M - 4, FN HI(B1 - ET)
410 IF L1 < > L2 THEN SH = .5 * (3 - SGN (L2 - L1)): PRINT "WA
RNING: PART ";SH;" IS "; ABS (L1 - L2);" UNITS SHORTER": PRINT "THAN
PART ";3 - SH;". SONG WILL END EARLY."
420 IF F1 THEN PRINT : PRINT "WARNING: DURATIONS OF SOME NOTES WERE": PRINT
"ROUNDED TO THE NEAREST INTEGER. TUNES": PRINT "MAY NOT BE SYNCHRON
IZED."
430 POKE 773, FN LO(B1): POKE 774, FN HI(B1)
440 POKE 775, FN LO(B2): POKE 776, FN HI(B2)
450 PRINT : INPUT COMS

```

```

460 IF LEFT$(COM$,2) < > "GO" THEN 500
470 INPUT "REPETITIONS? ";R
480 FOR I = 1 TO R
490 CALL 777: NEXT I: GOTO 450
500 IF LEFT$(COM$,6) = "CHANGE" THEN 180
510 IF LEFT$(COM$,4) = "EDIT" THEN HIMEM: M: LIST 697,: END
515 IF LEFT$(COM$,4) = "SWAP" THEN POKE 819,80 - PEEK (819): POKE 83
5,80 - PEEK (835): GOTO 450
520 IF LEFT$(COM$,4) < > "SAVE" THEN PRINT "WHAT?": GOTO 450
530 PRINT "TITLE (1-30 CHARACTERS):"
535 FILE$ = ""
540 FOR I = 1 TO 31
550 GET P$: IF P$ = CHR$(8) THEN I = I + 1: PRINT " "; CHR$(8); CHR$
(8);: GOTO 550
552 IF P$ = "," THEN P$ = ";"
555 IF P$ = CHR$(21) THEN 550
557 IF P$ = CHR$(24) THEN PRINT CHR$(92): GOTO 535
560 PRINT P$;: IF P$ = CHR$(13) THEN 580
565 FILE$ = FILE$ + P$
570 NEXT I: PRINT : PRINT B$;"TITLE TOO LONG": GOTO 530
580 PRINT D$"BSAVE ";FILE$;"A";ET;"L";M - ET
590 PRINT D$"LOCK ";FILE$
600 GOTO 450
680 Q = 1: IF P$ = "FLAT" THEN Q = - 1
690 READ SF$:LN = LEN (SF$): GOTO 210
692 READ M1,M2: IF I + M(M2) - M(M1) < E THEN 395
694 IF M(M2) > = M(M1) THEN 220
696 FOR K = M(M1) TO M(M2) + 1 STEP - 1: POKE I + K - M(M1), PEEK (K): NEXT
:I = I + K - M(M1):L = L + L(M2) - L(M1): GOTO 220

```

```

1 REM *****
2 REM * *
3 REM * MUSICAL DUETS *
4 REM * RICK BROWN *
5 REM * *
6 REM * COPYRIGHT (C) 1982 *
7 REM * MICRO INK, INC. *
8 REM * CHELMSFORD, MA 01824 *
9 REM * ALL RIGHTS RESERVED *
10 REM * *
11 REM *****
12 M = 38400: REM MUST BE SAME ADDRESS AS IN ASSEMBLER-PROGRAM
15 REM LOAD MACHINE LANGUAGE PROGRAM
60 PRINT CHR$(4)"BLOAD BROWN/TONE GEN.CODE"
80 DEF FN HI(X) = INT (X / 256)
90 ET = PEEK (43634) + PEEK (43635) * 256: REM CONTAINS BEGINNING ADD
95 HOME : GOTO 240
100 HIMEM: M:B1 = M - 4
110 PRINT
120 INPUT "TITLE? ";FILE$
130 PRINT CHR$(4)"BLOAD ";FILE$
150 B2 = B1 - ( PEEK (M - 1) + 256 * PEEK (M - 2))
170 T = B1 - ( PEEK (M - 3) + 256 * PEEK (M - 4))
180 ET = PEEK (43634) + PEEK (43635) * 256: REM CONTAINS BEGINNING ADD
RESS OF FILE$(FOR 48K SYSTEM)
190 HIMEM: ET
220 POKE 773, FN LO(B1): POKE 774, FN HI(B1)
230 POKE 775, FN LO(B2): POKE 776, FN HI(B2)
240 PRINT : INPUT COM$
250 IF COM$ < > "GO" THEN 280
260 INPUT "REPETITIONS? ";R
270 FOR I = 1 TO R: CALL 777: NEXT I: GOTO 240
280 IF COM$ = "LOAD" THEN 100
290 IF COM$ < > "SWAP" THEN 330
300 POKE 819,80 - PEEK (819): POKE 835,80 - PEEK (835)
310 GOTO 240
330 IF COM$ < > "CAT" THEN PRINT "WHAT?": GOTO 240
340 PRINT CHR$(4)"CATALOG": GOTO 240

```

Language Index

APPLESOFT BASIC

AMPER-SEARCH1	Amper-Search for the Apple, Hill	9
AMPER-SEARCH2	Amper-Search for the Apple, Hill	9
VARIABLE LISTER	Applesoft Variable Lister, Albright	24
FIAT-LOADER	Fast Fractional Math Package, Huntress	65
ERROR1-CALLER	Applesoft Error Messages from Machine Language, Cochard	84
TRICK DOS	Trick DOS, Mossberg	100
LACRAB	List and Cross Reference Applesoft BASIC, McBurney	107
LACRAB INSTRUCTIONS	List and Cross Reference Applesoft BASIC, McBurney	107
COLOR FILTER DEMO	Color Filter, Berggren	127
LISSAJOUS FIGURES	3-D Images, Radcliffe	131
NOISY COASTER	3-D Images, Radcliffe	131
STOCK HOLDINGS MGR	A Simple Securities Manager for the Apple, Guest	177
SOLAR SYSTEM SIMULATION	Solar System Simulation, Partyka	186
OTHELLO	Othello, Taylor	196
NOTE TABLE ASSEMBLER	Musical Duets, Brown	201
MUSICAL DUETS PLAYBACK	Musical Duets, Brown	201

INTEGER BASIC

FIREWORKS	Apple Bits, Vile	136
PATTERN MAKER	Apple Bits, Vile	136
LARGE DRIVER	Apple Bits, Vile	136
RANDOM WALK	Apple Bits, Vile	136
LOCOMOTIVE	Apple Bits, Vile	136

MACHINE LANGUAGE

LINE FINDER	Applesoft Line Finder Routine, Meyer	5
AMPER-SEARCH	Amper-Search, Hill	9
APPLESOFT VARIABLE LISTER OBJ	Applesoft Variable Lister, Albright	24
SHELL-METZNER SORT	Applesoft Variable Lister, Albright	24
DISASSMB	Double Barrelled Disassembler, Rosenberg	39
DISASSMB-SC	Double Barrelled Disassembler, Rosenberg	39
ROSS-ASSEMBLER	X-REFFING 6502 Programs with the Apple, Bongers	48
CROSS-SLOT-ZERO	X-REFFING 6502 Programs with the Apple, Bongers	48
FIAT	Fast Fractional Math Package, Huntress	65
ERROR1	Applesoft Error Messages from Machine Language, Cochard	84
ERROR2	Applesoft Error Messages from Machine Language, Cochard	84
GI	Serial Line Editor, Huntress	89
GETLNA	Serial Line Editor, Huntress	89
COLOR FILTER	Color Filter, Berggren	127
APPLE-BITS	Apple Bits, Vile	136
SPARKS	Apple Bits, Vile	136
LARGE LETTERS	Apple Bits, Vile	136
LITTLE MEN	Apple Bits, Vile	136
TRAIN	Apple Bits, Vile	136
TONE GEN	Musical Duets, Brown	201

TEXT FILES

LIST	List and Cross Reference Applesoft BASIC, McBurney	107
BROWN NOTES	Musical Duets, Brown	201

Author Index

(Biographies included)

- Albright, Richard 24
Employed by the U.S. Department of Transportation to develop software systems for nationwide deployment. Formed Sienna Software in 1981.
- Berggren, Stephen R. 127
Captain in the U.S. Air Force. Has owned an Apple for several years; especially interested in programming games.
- Bongers, Cornelis 48
Assistant professor of statistics at Erasmus University in Rotterdam, The Netherlands.
- Brown, Rick 201
Bachelors degree in physics. His programming interests include utilities, physical simulations, and artificial intelligence.
- Cochard, Steve 85
A principal of Scientific Software. Also, structural engineering supervisor with a large engineering/construction firm.
- Guest, Ronald A. 177
Computer scientist with Bell Telephone Laboratories. Involved in exploratory work in the area of operating systems.
- Hill, Alan 9
Apple owner and enthusiast since early 1978. Specialty: writing utility programs.
- Huntress, Wes 65, 89
Space scientist at the Jet Propulsion Lab in Pasadena. He works on the chemistry of planetary atmospheres. Has found the Apple very useful in his work.
- McBurney, N.R. 107
Southern Region Manager, Custom Applications, for General Electric's Information Services Co. Uses his Apple as an interface to his company's MIS.
- Meyer, Peter J.G. 5
Previously wrote programs in FORTRAN for scientific and technical applications. Currently is designing a system for interfacing Applesoft programs with machine-language subroutines.

- Mossberg, Sanford M. 100
 Although a physician by profession, also a programming enthusiast, and columnist for a club newsletter.
- Paris, Greg. 164
 Involved in neurobiology research; interested in programming micro-computer-based instrumentation.
- Partyka, David. 186
 Works as a programmer on an IBM 3031 OS for the May Department Stores Co.
- Radcliffe, Art. 131
 Has acquired 32 patents in computer and communication circuits and systems while working for IT & T, Radiation Inc., and Burroughs over 25 years. Also worked in optics and holography.
- Rosenberg, David L. 39
 Analyst with the Management Sciences department of Holiday Inns, Inc. Has been in computer field for nine years.
- Taylor, Charles F., Jr. 196
 Member of the faculty at the Naval Postgraduate School in Monterey, CA, where he teaches Operations Research and Computer Science.
- Vile, Richard C., Jr. 137
 Manager of a Software Technology group for Bell Northern Research, in Ann Arbor, MI.
- Woodward, Kim G. 157
 Works as a computer scientist for the U.S. Coast Guard in Washington, D.C.

A 002 HELLO
B 003 DISASSMB
B 003 DISASSMB-SC
B 006 CROSS ASSEMBLER
B 006 CROSS-SLOT-ZERO
B 006 FIAT
A 003 FIAT-LOADER
A 002 ERROR1-CALLER
B 002 ERROR1
B 002 ERROR2
A 008 AMPER-SEARCH1
A 010 AMPER-SEARCH2
B 005 AMPER-SEARCH
B 002 LINE FINDER
A 016 VARIABLE LISTER
B 002 APPLESOFT VARIABLE LISTER OBJ
B 002 SHELL-METZNER SORT
A 031 STOCK HOLDINGS MGR
A 039 SOLAR SYSTEM SIMULATION
A 014 OTHELLO
B 002 TONE GEN
A 015 NOTE TABLE ASSEMBLER
T 004 BROWN NOTES
A 006 MUSICAL DUETS PLAYBACK
B 002 COLOR FILTER
A 003 COLOR FILTER DEMO
A 005 LISSAJOUS FIGURES
A 011 NOISY COASTER
B 004 APPLE-BITS
I 004 FIREWORKS
B 010 SPARKS
B 010 LARGE LETTERS
I 016 PATTERN MAKER
I 007 LARGE DRIVER
I 006 RANDOM WALK
B 003 LITTLE MEN
B 003 TRAIN
I 006 LOCOMOTIVE
B 002 GI
B 003 GETLNA
A 031 TRICK DOS
A 042 LACRAB
A 006 LACRAB INSTRUCTIONS
T 002 LIST
A 012 BFILE PARAMETER LIST

Warranty

MICRO on the Apple

Although we've worked to create as perfect a diskette as possible, including hiring a reputable, reliable disk manufacturer to copy the diskettes, there is no guarantee that this diskette is error-free.

To cover the few instances of defective diskettes, we are providing the following warranty (this card must be filled out and returned to MICRO INK, Inc., immediately after purchase):

If within one month of purchase you find your diskette is defective, return the diskette to MICRO, along with \$1.00 to cover shipping and handling charges.

MICRO on the Apple

Volume 3

Recorded in 16-sector DOS 3.3 format.

Copyright © 1982 by MICRO INK
P.O. Box 6502
Chelmsford, MA 01824
All rights reserved

198b

Notice to Purchaser

When this book is purchased, this pocket should contain

- A. One floppy disk entitled *MICRO on the Apple, Volume 3*.
- B. A warranty card pertaining to the disk.

If either is missing, make sure you ask the seller for a copy.

The publisher hereby grants the retail purchaser the right to make one copy of the disk for back-up purposes only. Any other copying of the disk violates the copyright laws and is expressly forbidden.

MICRO on the Apple, Volume 3

19 Articles with More Than 40 Programs on Diskette!

MICRO INK, publisher of *MICRO, The 6502/6809 Journal*, is pleased to bring you *MICRO on the Apple*, Volume 3, the third in a series of books for the Apple.

Volume 3 offers interesting and useful programming aids, applications, and reference material, along with entertainment. Chapter titles include Applesoft Aids, Machine-Language Aids, I/O Enhancements, Graphics, Tutorial/Reference, and Recreation/Applications. The accompanying diskette is 16-sector, DOS 3.3 format.

Preliminary article selections were made by Ford Cavallari, Editor of Volumes 1 and 2. Final article selection, program testing and modifications were made by Apple expert Tim Osborn, who serves as an Editor on the staff of MICRO. Many authors provided their own updates and improvements.

**\$24.95 in U.S./Canada
(Including floppy disk)**

ISSN 0275-3537
ISBN 0-938222-08-2

**MICRO INK, Inc.
P.O. Box 6502
Chelmsford, Massachusetts 01824**

Warranty

MICRO on the Apple

Although we've worked to create as perfect a diskette as possible, including hiring a reputable, reliable disk manufacturer to copy the diskettes, there is no guarantee that this diskette is error-free.

To cover the few instances of defective diskettes, we are providing the following warranty (this card must be filled out and returned to MICRO INK, Inc., immediately after purchase):

If within one month of purchase you find your diskette is defective, return the diskette to MICRO, along with \$1.00 to cover shipping and handling charges.

If after one month of purchase, but within no time limit, this diskette proves defective, return it to MICRO with \$6.00 to cover replacement cost, shipping and handling.

Your date of purchase must be validated by your dealer; if purchased directly from MICRO, the valid date appears on this card.

Defective diskettes must be returned to MICRO to enable our quality assurance personnel to test and check the diskette. We need to know what caused the defect to avoid similar problems in the future.

We recommend that you try LOADING or BLOADING each program on the diskette immediately after purchase to ensure that the diskette is not defective.

Signature Date of purchase (Volume 2)

Address (please print):

Name

Street

City

State/Province/Country

Code

Other Products from MICRO

In addition to the MICRO on the Apple series, MICRO INK, Inc., produces several other products, including MICRO magazine, a monthly journal which reports on new 6502/6809 microprocessor family applications, systems, and developments. Other books published include the Best of MICRO series (anthologies of some of the best general-interest articles from MICRO), and *What's Where in the Apple*, (a detailed Atlas and memory map for the Apple II computer).

Ask your dealer for MICRO, or subscribe by completing this form:

	Yearly Rates	(U.S Dollars)
	Surface	Air Mail
United States	\$24.00	n/a
Canada	27.00	n/a
Europe	27.00	\$42.00
Mexico, Central America		
Middle East, North Africa		
Central Africa	27.00	48.00
South America, South Africa		
Far East, Australasia	27.00	72.00

MICRO Books

	At Your Dealer	Ordered by Mail	
		Surface	Air Mail
			<small>(Not U.S./Canada)</small>
Best of MICRO, Vol. 1	\$ 6.00	\$ 8.00	\$12.00
Best of MICRO, Vol. 2	8.00	10.00	15.00
Best of MICRO, Vol. 3	10.00	12.00	18.00
What's Where in the Apple	14.95	16.95	19.95
MICRO on the Apple (each volume)	24.00		

Note: Circle desired item.

Subscription rates are subject to change without notice. These prices are current as of January 1982.

- Check enclosed for \$ _____
- Bill VISA
- Bill MasterCard

Signature	Card Number	Expires
-----------	-------------	---------

Please print

Name

Street

City

State/Province/Country

Code

MICRO on the Apple

Volume 3

Recorded in 16-sector DOS 3.3 format.

Copyright © 1982 by MICRO INK

P.O. Box 6502

Chelmsford, MA 01824

All rights reserved

198b