

[54] **DIGITALLY-CONTROLLED COLOR SIGNAL GENERATION MEANS FOR USE WITH DISPLAY**

[75] Inventor: **Stephen G. Wozniak**, Cupertino, Calif.

[73] Assignee: **Apple Computer, Inc.**, Cupertino, Calif.

[21] Appl. No.: **110,409**

[22] Filed: **Jan. 8, 1980**

Related U.S. Application Data

[60] Continuation of Ser. No. 910,125, May 26, 1978, abandoned, which is a division of Ser. No. 786,197, Apr. 11, 1977, Pat. No. 4,136,359.

[51] Int. Cl.³ **G06F 3/14**

[52] U.S. Cl. **340/703; 340/725; 340/744; 340/800; 340/814; 358/17**

[58] Field of Search **358/17, 18, 28, 10; 340/703, 744, 725, 750, 800, 801, 814**

[56] **References Cited**

U.S. PATENT DOCUMENTS

3,571,513 3/1971 Ward 358/17
 3,624,634 11/1971 Clark 340/703

3,771,155 11/1973 Hayashi 340/703
 3,877,009 4/1975 Kanie et al. 340/703
 3,878,536 4/1975 Gilliam 340/728
 4,093,960 6/1978 Estes 358/10
 4,119,954 10/1978 Seitz et al. 340/728
 4,119,956 10/1978 Murray 340/728

Primary Examiner—Marshall M. Curtis
 Attorney, Agent, or Firm—Blakely, Sokoloff, Taylor & Zafman

[57] **ABSTRACT**

A microcomputer including a video generator and timing means which provides color and high resolution graphics on a standard, raster scanned, cathode ray tube is disclosed. A horizontal synchronization counter is synchronized at an odd-submultiple of the color subcarrier reference frequency. A "delayed" count is employed in the horizontal synchronization counter to compensate for color subcarrier phase reversals between lines. This permits vertically aligned color graphics without substantially altering the standard horizontal synchronization frequency. Video color signals are generated directly from digital signals by employing a recirculating shift register.

11 Claims, 4 Drawing Figures

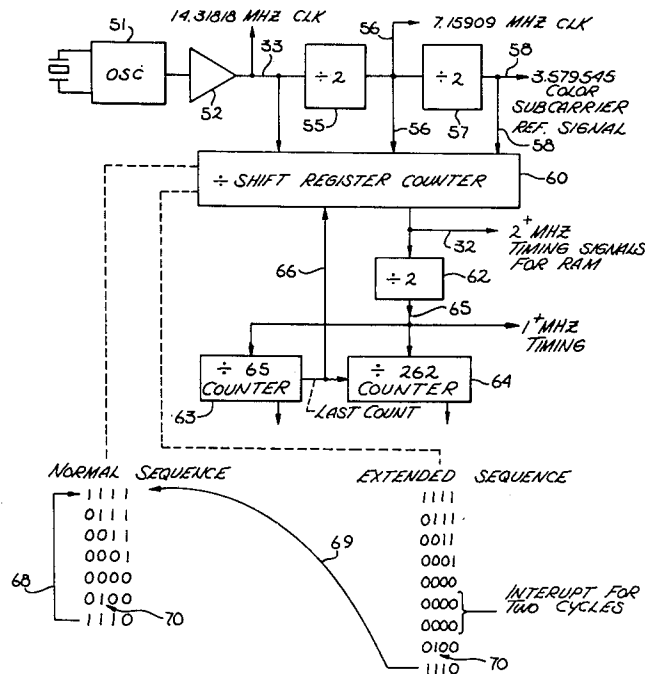

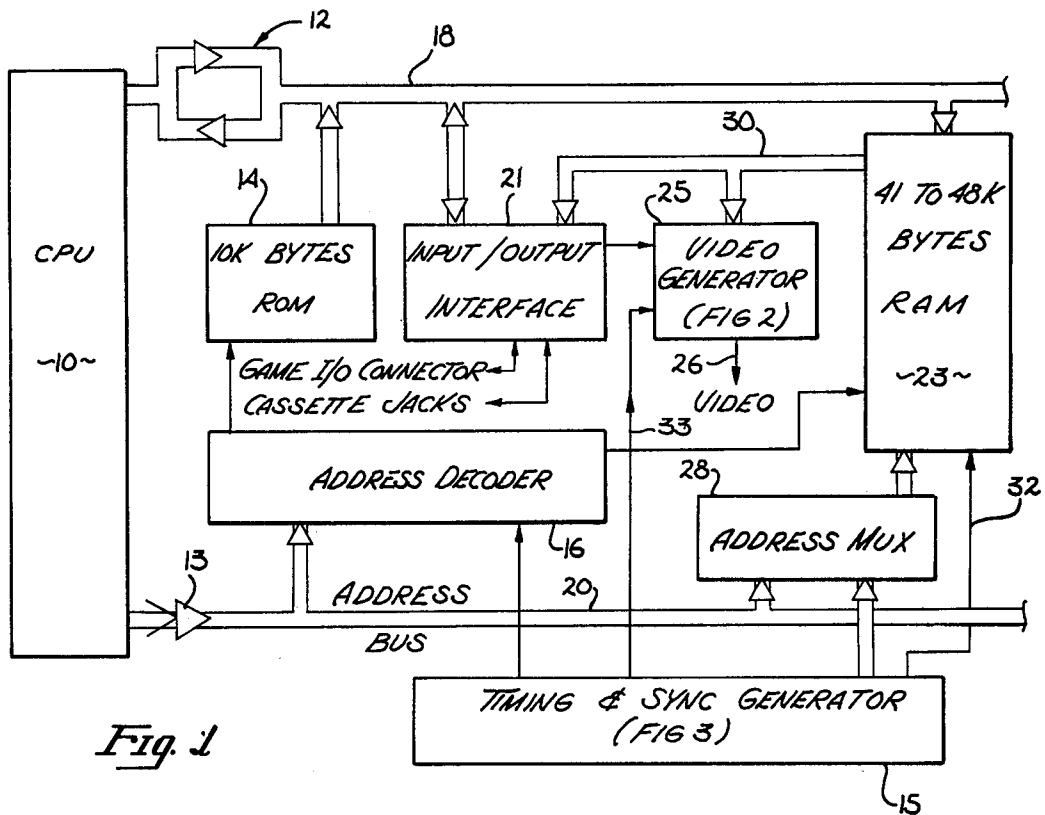

Fig. 1

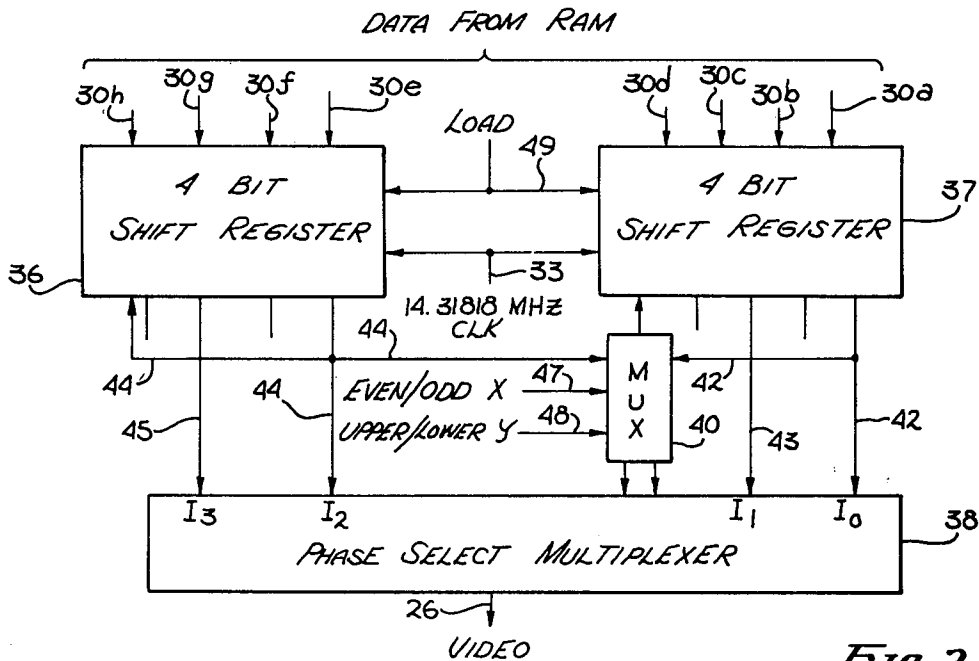

Fig. 2

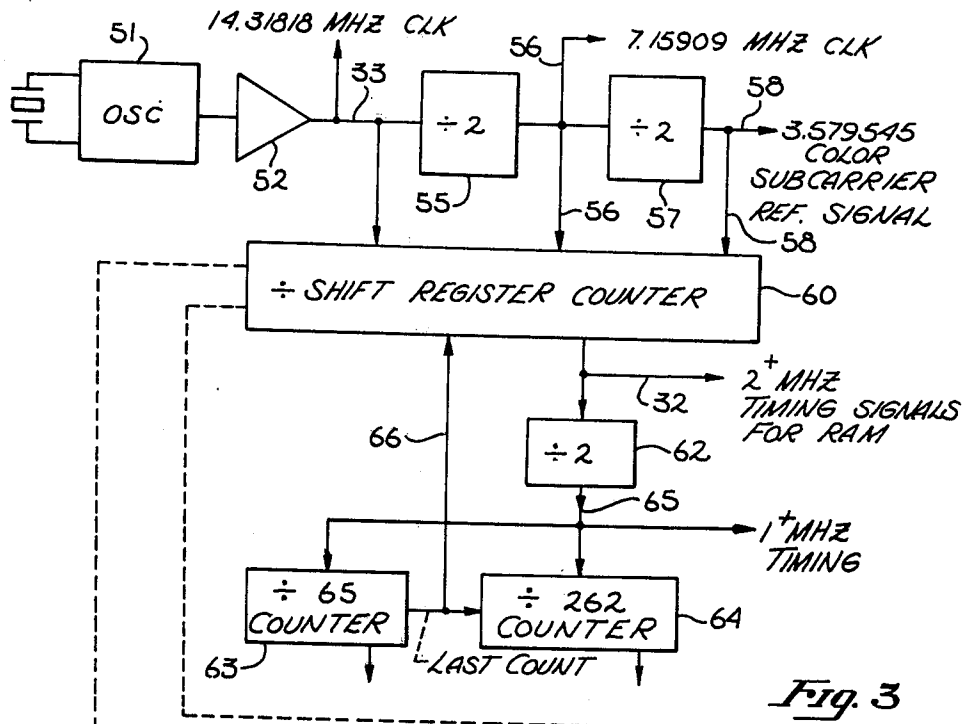

Fig. 3

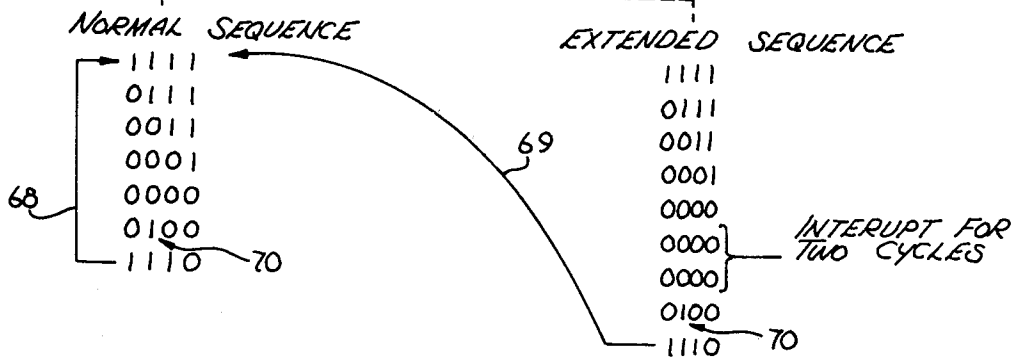
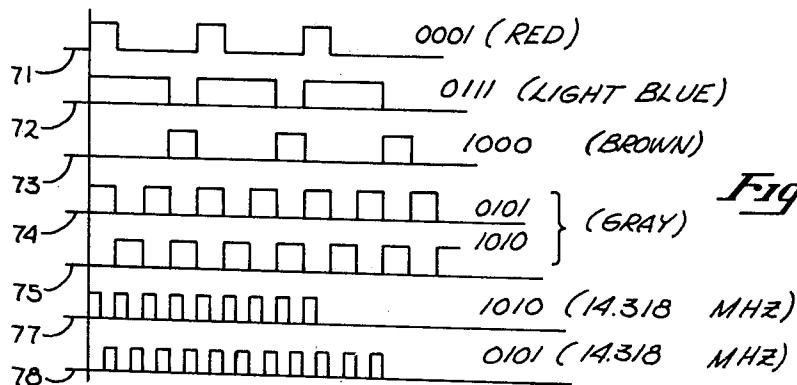

Fig. 4



DIGITALLY-CONTROLLED COLOR SIGNAL GENERATION MEANS FOR USE WITH DISPLAY

This is a continuation of application Ser. No. 910,125, now abandoned, filed May 26, 1978, which is a division of application Ser. No. 786,197, filed on Apr. 11, 1977 which is now U.S. Pat. No. 4,136,359.

BACKGROUND OF THE INVENTION

1. Field of the Invention

The invention is for the generation of signals for raster scanned video displays employing digital means, believed to be in Class 340-324.

2. Prior Art

With the reduced cost of large scale integrated circuits it has become possible to provide low-cost microcomputers suitable for home use. One such use which has flourished in recent years is the application of microcomputers in conjunction with video displays for games and graphic displays. Most often an ordinary television receiver is employed as the video display means. The standard, raster scanned, cathode ray tubes employed in these receivers and like displays, present unique problems in interfacing these displays with the digital information provided by the microcomputer.

In presenting color graphics it is, of course, desirable to provide high resolution lines and to avoid "ragged" lines. In a microcomputer controlled display, typically a single frequency reference source is employed to generate the color subcarrier reference signal of 3.579545 Mhz and the horizontal and vertical synchronization signals. If the frequency of the horizontal synchronization signals is to remain close to its normal frequency (i.e. 15,750 hz) the horizontal synchronization means must operate at an odd-submultiple of the color subcarrier frequency. When this occurs there is a phase reversal or phase shift of the color subcarrier reference signal when compared to color control signal between each of the lines of the display. This results in ragged vertical lines unless the color signals are changed for each line. One prior art solution to this problem has been to operate the horizontal synchronization counter at an even submultiple of the color subcarrier frequency (i.e. 15,980 hz). This deviation from the standard horizontal synchronization frequency typically requires manual adjustment of the receiver and for some receivers horizontal synchronization may be more difficult to maintain.

As will be described with the invented microcomputer, the horizontal counter operates close to its standard frequency (15,734 hz). Through use of a timing compensation means, counting in the horizontal synchronization counter is delayed to compensate for the fact that the counter operates at an odd-submultiple frequency of a color reference signal. In this manner, phase reversal of the color reference signal is eliminated and sharp graphic displays are provided without complex programming.

In many prior art microcomputer controlled displays, color information is stored as four digital bits which are used to designate green, red, blue, and high/low intensity. The color generation means generally includes a signal generator for generating the pure color signals (CW). These pure color signals are then gated and mixed in accordance with the binary state of the four bits to provide a color signal compatible with standard television receivers. Generation of the video color sig-

nal in this manner is complex and requires a substantial amount of circuitry.

The invented microprocessor includes a recirculating shift register which circulates four bits of information. In this manner video color signals are generated directly from digital information without the cumbersome generation techniques employed in the prior art.

SUMMARY OF THE INVENTION

A microprocessor for use with a video display is described. The microprocessor includes an improved timing apparatus which provides well-defined color graphics on a standard, raster scanned, cathode ray tube. A timing reference means is employed to provide a color reference signal for the video display. A horizontal synchronization means which is synchronized to the timing reference means provides horizontal synchronization signals for the display. These signals occur at a rate which is an odd-submultiple of the color reference signal frequency. The timing apparatus includes a compensation means which is coupled to both the timing reference means and the synchronization means for periodically adjusting the horizontal synchronization signals such that these signals remain in phase relationship with the color reference signal.

The microcomputer also includes a unique color signal generation means which uses a recirculating shift register. This register receives digital signals representative of color from memory and circulates this data at a predetermined rate. In this manner a color signal suitable for use with a video display is generated from the digital signals.

BRIEF DESCRIPTION OF THE DRAWINGS

FIG. 1 is a general block diagram illustrating the invented microcomputer in its presently preferred embodiment.

FIG. 2 is a block diagram of the video generator employed in the microcomputer of FIG. 1.

FIG. 3 is a block diagram of the timing and synchronization generator employed in the computer of FIG. 1; and

FIG. 4 is graph illustrating several waveforms generated by the video generator of FIG. 2.

DETAILED DESCRIPTION OF THE INVENTION

A microcomputer is disclosed which is particularly suitable for controlling color graphics on a standard, raster scanned, cathode ray tube. The described microcomputer includes a video generator which generates color signals directly from digital information, and a timing means which provides well defined color graphics, particularly in the vertical direction, with complex programming.

In the following description, numerous well-known circuits are shown in block diagram form in order not to obscure the described inventive concepts in unnecessary detail. In other instances, very specific details such as frequencies, number of bits, specific codes, etc., are providing in order that these inventive concepts may be clearly understood. It will be apparent to one skilled in the art that the described inventive concepts may be employed without use of these specific details.

Referring now to FIG. 1, the microcomputer includes a central processing unit (CPU) or microprocessor 10. While any one of a plurality of commercially available microprocessors may be employed such as the

M6800 or 8080, in the presently preferred embodiment, a commercially available microprocessor, Part No. 6502, is employed. CPU 10 communicates with the data bus 18 through a bidirectional tri-state buffer 12. The CPU 10 is also coupled to the address bus 20 through a tri-state buffer 13.

The microcomputer, in its presently preferred embodiment, includes two memories. The first is a 12K (bytes) read-only memory (ROM) 14 which is coupled to the data bus 18. This ROM may be a mask programmable memory, E PROM or other read-only memory. The primary data storage for the computer comprises the random-access memory 23. In the presently preferred embodiment, this memory may contain 4K to 48K (bytes) and comprises commercially available dynamic MOS memories. The RAM 23 is coupled to the input/output interface means 21 via bus 30, the data bus 18 and the video generator 25.

The timing signals for the microcomputer are provided by the timing and synchronization generator 15. The novel portions of this generator shall be described, in detail, in conjunction with FIG. 3. This generator provides timing signals for the microcomputer, and additionally, synchronization signals for the video display. Among the signals provided by the generator 15 are 2+ Mhz timing signals on lines 32 for the RAMs 23 and a 14.31818 Mhz signal on line 33 for the video generator 25. The timing and synchronization generator 15 also provides timing signals for the decoder 16 and for the address multiplexer 28.

The address decoder 16 receives address signals from the address bus 20 and decodes them in a well-known manner. The address decoder 16 is coupled to the ROM 14 and to the RAM 23. Address signals are also received from the bus 20 by the address multiplexer 28 which couples these signals to the RAM 23.

The input/output interface means 22 provides ports which allows the microprocessor to be electrically coupled to a cassette jack or to a connector used for receiving game input/output signals. Known buffers and timing means may be employed for this purpose.

The video generator 25 receives signals from the input/output interface means 21 and also from the RAM 23. This generator provides an output video signal on line 26. Video generator 25 shall be described, in detail, in conjunction with FIG. 2.

In the presently preferred embodiment, the entire microcomputer of FIG. 1 is fabricated on a single printed circuit board. This board includes connectors to allow the computer to be connected to a cassette playback means, or other devices. As will be appreciated, numerous well-known interconnections, driver means and other circuits employed in the microcomputer are not shown in FIG. 1. For a detailed description of circuits and interconnections which may be employed in the microprocessor of FIG. 1, including a transparent refresh cycle for the RAMs 23, see "A CRT Terminal Using The M6800 Family" by Roy & Morris, *Interface Age*, Volume 2, Issue 2, January 1977.

Referring now to FIG. 3, the timing and synchronization generator (timing means) includes a frequency reference source, crystal oscillator 51. The output of oscillator 51 is coupled to a buffer 52 which provides a 14.31818 Mhz signal on line 33 for the presently preferred embodiment. This signal is coupled to the video generator of FIG. 2 as will be described, and is also coupled to the shift register counter 60 and the divider 55. The divider 55 divides the 14.31818 Mhz signal by

two, thereby providing a 7.15909 Mhz signal on line 56. This signal is employed by the microprocessor as a timing signal, and additionally, is employed by the shift register counter 60 as a feedback synchronization signal. The signal on line 56 is further divided by two, by divider 57, to provide the standard color subcarrier reference signal of 3.579545 Mhz on line 58. The signal on line 58 is used in an ordinary manner by the video display and also is used as a feedback synchronization signal by the shift register counter 60.

The 14.3 Mhz signal on line 33 is divided by seven, by the shift register counter 60 to provide a 2+ Mhz signal on line 32. This signal is used by the RAMs 23 of FIG. 1. This 2+ Mhz signal is further divided by divider 62 (divided by two) to provide a 1+ Mhz timing signal on line 65. This 1+ Mhz signal in addition to being employed elsewhere in the microprocessor is used by counters 63 and 64.

The "divide-by-65" counter 63 is used to provide the horizontal synchronization signals. When the maximum count is reached within the counter 63, a signal is provided on line 66 to shift register 60 and also to the vertical synchronization counter 64. The counter 64 is employed to divide this signal by 262 to provide vertical synchronization signals.

In the presently preferred embodiment, the display is divided into a 65x262 array. However, 25 of the 65 horizontal character positions are employed for blanking and 70 of the 262 lines are also employed for blanking.

It is apparent from FIG. 3 that the horizontal synchronization signals from counter 63 occur at a frequency of approximately 15,734 hz. This is very close to the standard horizontal synchronization rate of 15,750 hz. Each count of the counter 63 includes 3½ color cycle of the color subcarrier reference frequency; moreover, the total number of color cycles per line is a non-integer. As a result, the color subcarrier reference signal will be shifted 180° for each new line. Unless some corrective action is taken this will result in ragged vertical lines. As will now be described, compensation is provided by delaying the occurrence of the 1+ Mhz timing signal once for each line by a period of time corresponding to ½ cycle of the 3.58 Mhz subcarrier reference signal.

As shown in FIG. 3, the normal counting sequence for the shift counter 60 includes seven states. When the last stage of the four stage counter contains a binary-zero, a binary-one is loaded into the second stage (position 70). The first and second stages receive the output of the second stage when the last stage contains a binary-zero. Thus, the states become 1110 after the next shift, and finally the states become 1111 as indicated by path 68.

Each time a signal occurs on line 66 (every 65 cycles of the 1+ Mhz signal) the normal sequencing within the counter 60 is altered as shown by the extended sequence of FIG. 3. When a signal occurs on line 66 and when the count of 0000 is reached, the loading of the binary-one into the second stage (position 70) is delayed for two cycles of the 14.318 Mhz clock. These two cycles correspond to 180° of the 3.58 Mhz signal. After these two cycles, a binary-one is then loaded into the second stage, followed by the loading of binary-ones into the first and third stages. As indicated by path 69, a normal counting sequence then occurs. By extending the count within counter 60 as described, compensation occurs

which provides vertical color alignment from line-to-line.

Referring now to FIG. 2, the video generator 25 of FIG. 1 includes two, four bit shift registers 36 and 37. Each of these four bit shift registers is coupled to receive four bits of data on lines 30 from the RAM 23. The registers 36 and 37 receive a load signal on line 49 which causes the data on lines 30a through 30h to be shifted into the registers. The first stage of register 37 (I₀) is coupled to a multiplexer 38 by line 42. The third stage of register 37 (I₁) is also coupled to the multiplexer 38 by line 43. In a similar fashion, the first stage of the register 36 (I₂) is coupled by line 44 to the multiplexer 38, and the third stage of this register (I₃) is also coupled to the multiplexer 38 by line 45.

Line 44 is coupled to the fourth stage of register 36 in order that four bits of data within register 36 may be recirculated. (Registers 36 and 37 shift data from left to right, that is, toward their first stage). The line 42 may be selectively coupled to the fourth stage of register 37 through the multiplexer 40 in order that four bits of data within register 37 may be recirculated. Line 44 may be coupled through the multiplexer 40 to the fourth stage of the shift register 37. When this occurs, the shift registers 36 and 37 operate as a single eight bit shift register.

Control signals designated as even/odd X (line 47) and upper/lower Y (line 48) are used to control multiplexer 38. During the color graphics mode the registers 36 and 37 operate as separate registers and data is alternately selected for coupling to line 26 by multiplexer 38. The upper/lower Y signal, during the color graphics mode, allow selection of data from either register 36 or 37. The odd/even X signal then toggles the data from the selected register by alternating selecting I₀ or I₁ if register 37 is selected, or I₂ or I₃ if register 36 is selected.

During the color graphics mode as presently implemented, eight bits of color information are shifted (in parallel) into the registers 36 and 37 from the RAM 23 at a 1+ Mhz rate. This data is recirculated within registers 36 and 37 at a rate of 14.31818 Mhz by the clocking signal received on line 33. The circulation of the data bit within the registers 36 and 37 at this rate provides signals having a 3.58 Mhz component and as will be described, these signals may be readily employed for providing color signals for video display.

In the color graphics mode, as presently implemented, each of the display characters is divided into an upper and lower color rectangle. The RAM 23 provides the four bits of color data for the upper rectangles to registers 36 and for the lower rectangles to register 37. This color data for the presently preferred embodiment is coded as follows:

Red	0001	Medium Violet	0011
Pink	1011	Medium Blue	0110
Blue	0010	Medium Green	1100
Light Blue	0111	Orange	1001
Dark Green	0100	White	1111
Light Green	1110	Gray	1010
Brown	1000	Gray	0101
Yellow	1101		

When colors are coded in this manner and circulated at the rate of 14.318 Mhz in the registers, video color signals compatible with standard television receivers are produced. The resultant signal for red is shown on line 71 of FIG. 4, light blue on line 72, brown on line 73 and gray on lines 74 and 75.

Briefly referring again to FIG. 3, each count of the horizontal synchronization counter 63 corresponds to 3½ cycles of the subcarrier reference signal. Thus, a 180° phase shift occurs from character-to-character with respect to the color subcarrier reference signal. This means that the color signals must be shifted by 180° by the generator of FIG. 2, or the coding for these signals must be alternated for odd and even horizontal character positions. In the presently preferred embodiment, a 180° phase shift for the color signals is obtained by toggling between the first or third stages of the selected registers. For example, assume that the lower portion of a character is being displayed and that the color information is thus contained within register 37. Further assume that this information is being circulated, that is, line 42 couples stage 4 to stage 1 through the multiplexer 40. For even horizontal character positions, as indicated by the signal on line 47, the phase select multiplexer 38 couples the I₀ signal to line 26. For the odd positions, a 180° phase shift is obtained by selecting the I₁ signal.

During a second mode of operation the generator of FIG. 2 is used for providing high resolution graphics. In this case, eight bits of information are provided by the RAM 23 to the registers 36 and 37. For this high resolution mode line 42 is coupled to the video line 26 and the eight bits of data from RAM 23 are serially coupled to the video line 26 at the 14.318 Mhz rate. The multiplexer 40 couples line 44 to the fourth stage of register 37 to provide a single eight bit shift register. The resultant signals are shown on lines 77 and 78 of FIG. 4. The signals on lines 77 and 78 provide either a green or violet display. In the presently preferred embodiment, data changes are employed to obtain the compensation provided by the multiplexer 38 during the color graphics mode.

Thus, a microcomputer has been disclosed which is particularly suitable for controlling a color video display. The unique timing means provides well defined vertical color lines without complicated programming changes while allowing the generation of horizontal synchronization signals at close to the standard rate. The unique video generator allows the generation of color signals directly from digital signals without the complex circuitry often employed in the prior art.

I claim:

1. A digitally controlled color signal generation means for use with a color video display adapted to receive color signals having a color subcarrier reference signal of frequency N, said color signal generation means comprising:

means for generating at least one digital word which corresponds to a predetermined color, said digital word comprising a plurality of bits;

storing means for storing said digital word;

sampling means coupled to said storing means for sequentially sampling each of said bits of said digital word at a predetermined sampling rate, said sampling rate being selected such that a color signal is developed at an output of said sampling means which corresponds to said predetermined color and which has a frequency component at said frequency N,

whereby a color signal suitable for use with the video display is generated.

2. The color signal generation means of claim 1 wherein said sampling means comprises a recirculating shift register means for receiving said digital word from

said storing means and for circulating said digital word in said shift register means at said predetermined sampling rate.

3. The color signal generation means defined by claim 2 wherein said digital word is comprised of P number of bits, said shift register means comprises a recirculating shift register having P number of stages, and said predetermined sampling rate is at a frequency approximately equal to $N \times P$.

4. The color signal generation means defined by claim 3 wherein P is equal to four.

5. The color signal generation means defined by claim 4 wherein N is approximately 3.58 MHz and said predetermined sampling rate is approximately 14.318 MHz.

6. The color signal generation means defined by claim 5 wherein said sampling means further includes phase shifting means for coupling different stages of said shift register to said output thereby allowing the selection of a phase shifted signal.

7. The color signal generation means defined by claim 6 wherein said digital word corresponding to the color red is 0001.

8. A digitally controlled color signal generation means for use with a color video display adapted to receive color signals having a color subcarrier reference signal of frequency N, said improved color signal generation means comprising:

means for generating at least one digital word which corresponds to a predetermined color, said digital word comprising P number of bits;

storing means for storing said at least one digital word;

sampling means coupled to said storing means for sequentially sampling each of said bits of said digital word at a sampling rate approximately equal to a frequency of $N \times P$;

whereby a color signal suitable for use with the video display is developed at an output of said sampling means.

9. The color signal generation means defined by claim 8 wherein said sampling means includes phase shifting means for altering the sequence of said sequential sampling, thereby allowing the selection of a phase shifted signal at said output of said sampling means.

10. The color signal generation means defined by claim 9 wherein N is approximately equal to 3.58 MHz, P is equal to four and said sampling rate is at a frequency approximately equal to 14.318 MHz.

11. The color signal generation means defined by claim 10 wherein said sampling means comprises a recirculating shift register having four stages which receives said digital word from said storing means, with said shift register being clocked at a frequency approximately equal to 14.318 MHz and said phase shifting means is a means for coupling different stages of said shift register to said sampling means output.

* * * * *

30

35

40

45

50

55

60

65